

What is Steam?

Steam is simply the gas that is formed when water is heated to its boiling temperature at a given pressure.

A tea kettle is the most common example of producing steam by heating water to its boiling temperature (212°F). In this case, the steam does not develop any pressure and is released into the atmosphere. A boiler will generate steam under pressure by heating a large quantity of water in a contained system. This pressurized steam will travel throughout the pipes in the system to where it is needed. In addition to being created from water, which is readily available and relatively inexpensive, steam has many other advantages that make it easy and efficient to work with.

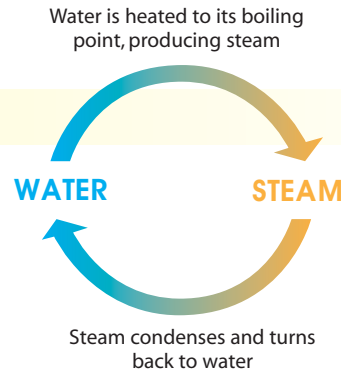

What makes steam desirable to use for heating?

Another benefit of using steam is that steam temperature is directly related to the pressure of the system. Therefore, by increasing or reducing pressure, it is easy to increase or reduce the temperature.

The Steam & Condensate Loop

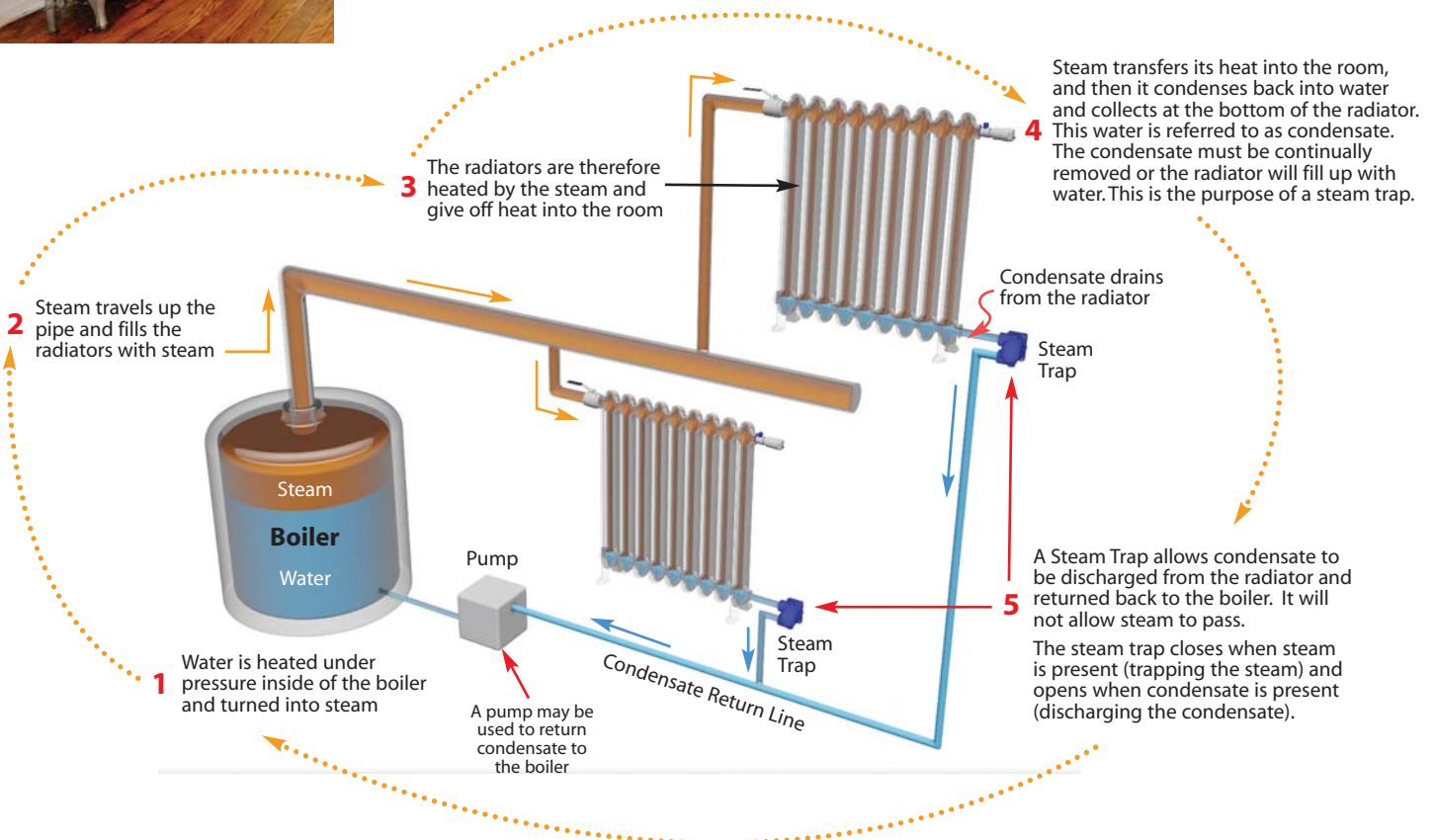

Introduction

Pressure / Temperature Relationship of Steam

Steam is created when water is heated to its boiling temperature until enough heat energy is absorbed to transform the water from a liquid to a gas. The temperature at which water boils is 212°F; however, this is the boiling point of water at 0 psig, or atmospheric pressure. A unique property of steam is that there is a direct relationship between the pressure at which it is generated and the temperature at which it boils.

The boiling temperature increases as steam pressure increases. If steam is generated at a pressure higher than 0 psig, the temperature at which the water boils will be higher than 212°F. An abbreviated version of the Saturated Steam Table is included to show the exact boiling temperature at various steam pressures. (The complete steam table is available in Engineering Section.)

Steam Pressure (psig)	Temperature (°F)	
	Steam	Boiling Water
0 psi =	212° F	212° F
1 psi =	215° F	215° F
4 psi =	224° F	224° F
10 psi =	239° F	239° F
50 psi =	298° F	298° F
100 psi =	338° F	338° F
150 psi =	366° F	366° F
200 psi =	388° F	388° F
300 psi =	421° F	421° F

Steam Supplies Heat at a Constant Temperature

Steam does not reduce its temperature when it releases its heat; it just simply changes from a gas back into water at the same temperature. For example, steam at 50 psig (is at 298°F; refer to steam chart above) will condense back to water at 298°F when it releases its heat energy. In contrast to steam, water reduces in temperature when it gives up its heat.

What is saturated steam?

Steam that is generated under pressure inside the boiler, while in the presence of boiling water, is referred to as **Saturated Steam**. If additional heat is later added to the saturated steam to increase its temperature, it is then referred to as Superheated Steam. Superheated steam is used in power generation and saturated steam is used for heating. When saturated steam releases its energy, it condenses back to water. This hot water at or near boiling temperature is referred to

Heating Properties: The energy absorbed by water at its boiling point to transform it from a liquid to a gas is known as **Latent Heat**. This Latent Heat is then released by the steam when used for heating. Steam is very efficient in transferring heat to other processes. Steam, being a gas, allows it to surround any surface it needs to transfer its heat energy into. When steam transfers its heat, it condenses back into water, which will be drained away and sent back to the boiler in order to be used again (referred to as Condensate Recovery).

Where else is steam used?

Hospitals and pharmaceutical manufacturers may use steam for the sterilization of medical instruments and production of medicines, while the petrochemical industry may use steam for processing gasoline from crude oil. Steam is essential in large scale food processing & manufacturing applications. Large cities, such as New York, have centralized steam systems for heating large apartment complexes.



Steam Turbines in Power Plants



Steam exhaust from power plants



Steam used in cities for heat

Typical equipment used for process heating in steam systems

A steam jacketed kettle contains a liquid to be heated surrounded by an isolated jacket containing the steam (steam does not contact the fluid). They are typically found in commercial food processing facilities. The Shell & Tube Heat Exchanger is used for continuous processes where a liquid to be heated (such as water), continually flows through the tubes surrounded by the steam.

Steam Jacketed Kettle

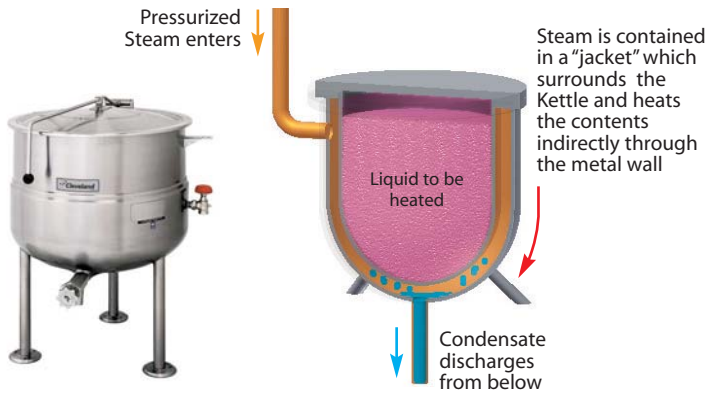

Shell & Tube Heat Exchanger

(Single tube shown for clarity)

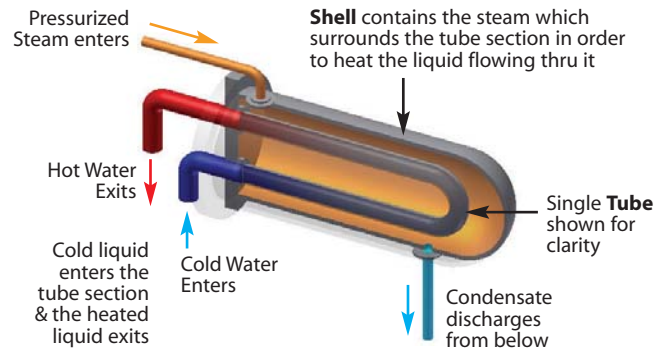

Typical pieces of equipment used to control, protect and optimize steam systems

Now that a basic understanding of steam has been provided, let's introduce some components of the system and their general purposes:



Steam Traps

Since steam is created from water, it will condense back to water after releasing its energy during heating. This water, or condensate, must be removed to not only ensure proper heat transfer, but system safety as well. Removing condensate without the loss of live steam is the primary function of Steam Traps. Steam traps also discharge air that is present in the system prior to system start-up.



Pressure Regulators & Control Valves

Steam is generated at the boiler at pressures sufficient to ensure travel throughout the entire piping system. Pressure Regulating Valves and Control Valves may be used for temperature control or to reduce the steam pressure generated at the boiler down to more usable levels.



Condensate Return Pumps

When condensate does not have sufficient pressure to return to the boiler on its own, mechanical or electric pumps are required to pump the condensate back to the boiler.

Introduction

How does steam flow in a system?

Steam coming from the boiler is distributed throughout the system by pipes referred to as steam mains or steam supply lines. Since steam is generated under pressure at the boiler, it will travel on its own through the system. Steam may travel in pipes at velocities exceeding **90 mph**; for this reason, care should always be taken to open and close valves slowly.

What is condensate and why must it be removed from a system?

When steam releases its heat energy, it condenses from a gas back to a liquid. This “condensed” steam is referred to as **condensate**... which is nothing more than extremely hot water. As previously discussed, steam at 50 PSIG condenses back into water at 298°F. Steam Traps were specifically designed for the removal of unwanted **Condensate** and **Air**.

Condensate will form in steam pipelines due to radiation losses through the pipe walls. Drip Traps remove condensate from steam pipelines. However, the bulk of the condensate formed in the system occurs in the heat exchangers and other processes, and must be removed or the system would fill with water and impede the heat transfer process. In contrast to drip traps, Process Traps remove condensate from the actual process application (such as a heat exchanger).

System showing use of Steam for Heating in two different Process Applications: Steam Jacketed Kettle & Tank with Steam Coil (Vat Process)

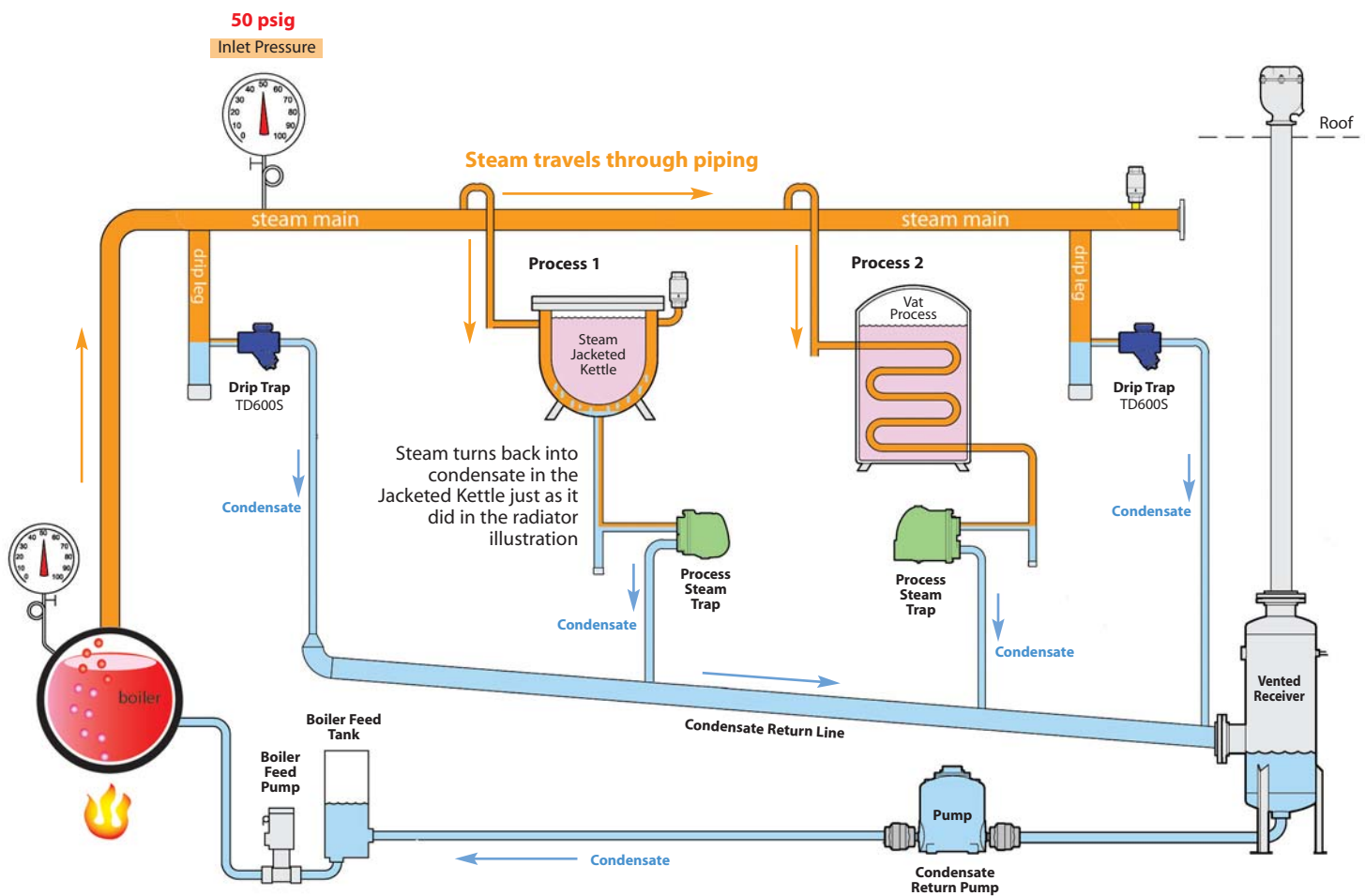

Note the process steam traps draining condensate from the Steam Jacketed Kettle and the Vat Process, discharging into a condensate return line. Condensate is then drained into a vented receiver which is used to release flash steam from the hot condensate in order to neutralize the pressure in the condensate return line. Also note the drip traps used for draining condensate from the steam supply lines. Other components, such as control valves and pressure regulating valves that would be required to control steam pressures and product temperatures, have not been included for simplification purposes.

WHY ARE STEAM TRAPS REQUIRED?

The purpose of the steam trap is to allow Condensate (water that is formed from the condensed steam) and air, to be discharged from the steam system while preventing the loss of live steam. The steam trap is a special type of valve which opens when condensate and air are present and closes when steam tries to pass.

CONDENSATE: (condensed steam or water): Any time steam releases its heat energy (latent heat), the steam condenses back to water. This water is therefore referred to as condensate. This transformation of steam back to liquid condensate will occur in a radiator heating a room, in a heat exchanger making hot water, in a pipe transferring the steam over long distances, or in any process that uses steam. If this condensate is not continuously removed, the radiators, heat exchangers and piping will fill with condensate (water). The removal of condensate from the steam system, while preventing the loss of live steam, is therefore the primary function of the steam trap.

AIR: Before the steam is turned on and the system is cold, air will exist in all the steam pipes and process equipment, such as radiators and heat exchangers. This air must be bled from the entire system to allow the steam to enter and reach its intended designated process. The air is actually pushed thru the system by the incoming steam and automatically bled thru the process traps at the end of the steam lines or special air vents at the high points in the system. This bleeding of air from the system allows the steam to enter.

GENERAL APPLICATION CATEGORIES for STEAM TRAPS:

DRIP APPLICATIONS: Drip applications refer to removing the condensate that forms in the steam main and steam supply lines as opposed to condensate that forms at the actual process (heat exchanger, jacketed kettle, radiator, etc.). When steam loses its heat energy due to radiation losses through the pipe walls, condensate forms in the pipes. This condensate needs to be continuously removed, and it is therefore common to have steam traps placed 150–300 feet apart throughout the piping system. Traps used for this application are referred to as drip traps and have small condensate capacities as opposed to process traps. Drip traps are not normally relied upon to discharge the air from the system. Air removal is performed by the process traps and air vents located throughout the system. The most common trap choices for drip applications are the **Thermodynamic** style for line pressures over 30 PSIG, and Float & Thermostatic style for line pressures up to 30 PSIG. **Inverted Bucket (IB)** style traps are also commonly used for drip trap applications. The orifice of the IB is mounted at the top of the trap which makes them less susceptible to failure from dirt and pipe scale when compared to other trap types.

PROCESS APPLICATIONS: Process applications refer to removing condensate and air where the actual process using the steam is taking place. This process could be a heat exchanger making hot water, or a radiator heating a room, or anything else that requires the use of steam. Traps used for process applications require larger condensate handling capability in contrast to steam traps that are used for drip applications. Traps used in Process applications also need to be able to discharge large amounts of air present in the system at start-up. The most common trap choice for process applications are **Float & Thermostatic** traps since they do an excellent job of discharging condensate and air. **Thermostatic** traps make a good choice for process applications since they also do an excellent job of discharging air and condensate. In contrast, the lack of air venting capability of the Thermodynamic and Inverted Bucket traps, make these trap types a less desirable choice for most process applications.

Common Types of Steam Traps

Shown below are some of the most common types of steam traps; Float and Thermostatic, Thermodynamic, Thermostatic, as well as a Thermostatic Air vent. Other common steam trap types are the Inverted Bucket and the Bi-Metal. In the following diagrams, other system components such as control valves and regulating valves are often required to control steam pressure and process temperatures. (Some piping components may not be included in the diagrams for simplification purposes.)

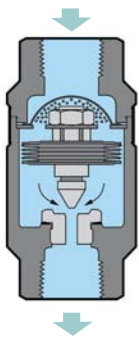

Thermostatic Trap

Contains a thermostatic element which allows air and condensate to be discharged, but closes when steam is present.

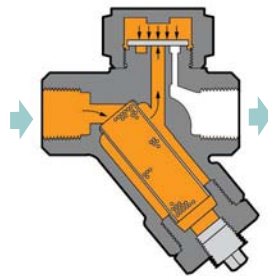

Thermodynamic Trap

Contains a disc and seat arrangement which allows condensate to be discharged, but will close when steam tries to pass through.

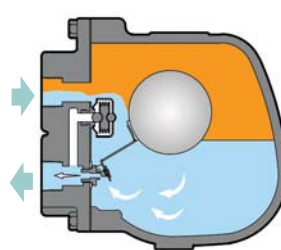

Float & Thermostatic Trap

Contains a float-operated valve to discharge condensate, and a thermostatic air vent which discharges air, but will close when steam is present.

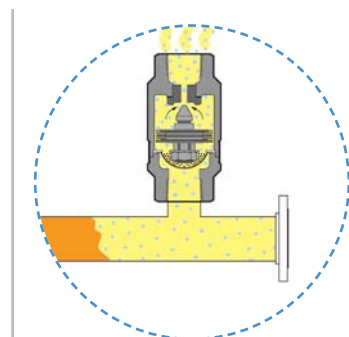

Thermostatic Air Vent

Air Vents are used in steam systems for the removal of air and other non-condensable gases. They are placed at the end of steam mains and directly on process equipment.

DRIP APPLICATION:

Drip applications refer to **removing the condensate that forms in the steam pipes** as opposed to condensate that forms at the actual process. It is appropriate to have steam traps (drip traps) placed 150 to 300 feet apart.

AIR VENT: Placed at the end of steam mains and other high points in order to remove air from the system.

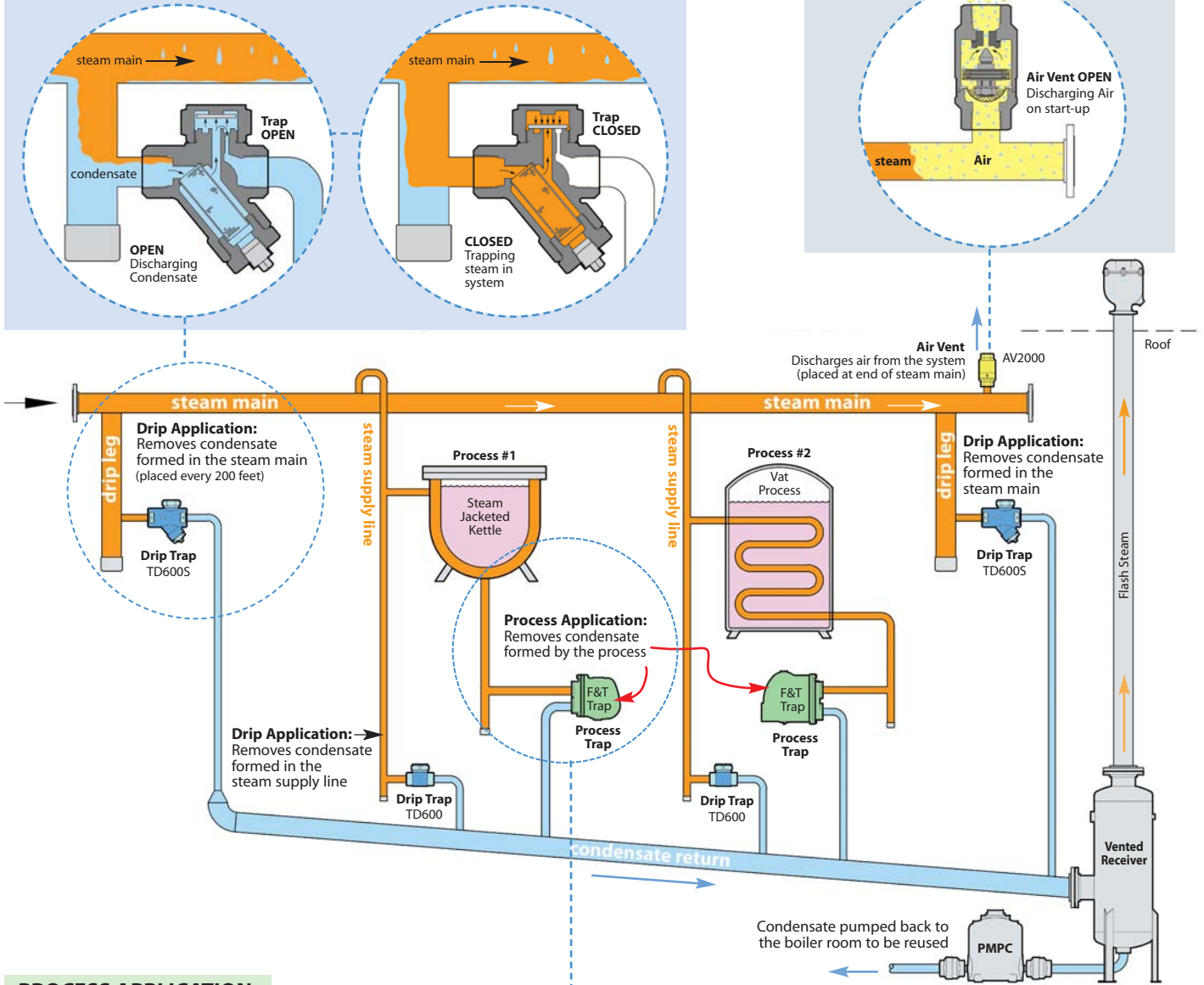

PROCESS APPLICATION:

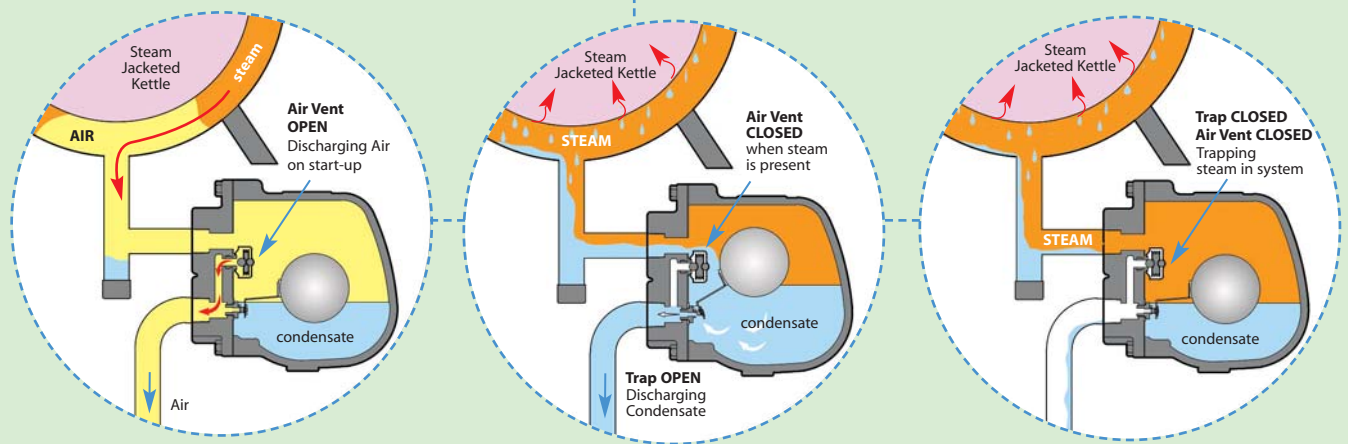

Process Applications refer to **removing condensate and air from the actual process** where steam is being used. This process could be a heat exchanger making hot water, or a radiator heating a room, or anything else that requires the use of steam. Traps used for process applications require larger condensate handling capability than steam traps used for drip applications and also need to be able to discharge large amounts of air.

How does condensate flow through steam traps? *Steam Pressure pushes the condensate through the trap.*

Every steam trap has an **Inlet Pressure** (Steam Supply Pressure) and an **Outlet Pressure**. The difference between inlet & outlet pressure is referred to as the **Differential Pressure**. When the Inlet Steam Pressure is higher than the Outlet Pressure (Positive Differential Pressure), the steam will "PUSH" the condensate through the steam trap.

Differential Pressure is an important factor for sizing steam traps as well as other components, such as regulators and control valves. The higher the Inlet Pressure in relation to the Outlet Pressure, the more condensate the trap can remove from the steam system. The trap capacity is therefore a function of the differential pressure across the trap.

$$\begin{array}{rcl}
 \text{Inlet Pressure (Steam)} & - & \text{Outlet Pressure (Condensate)} = \text{Differential Pressure} \\
 50 \text{ psig} & - & 0.0 \text{ psig} = 50 \text{ psi}
 \end{array}$$

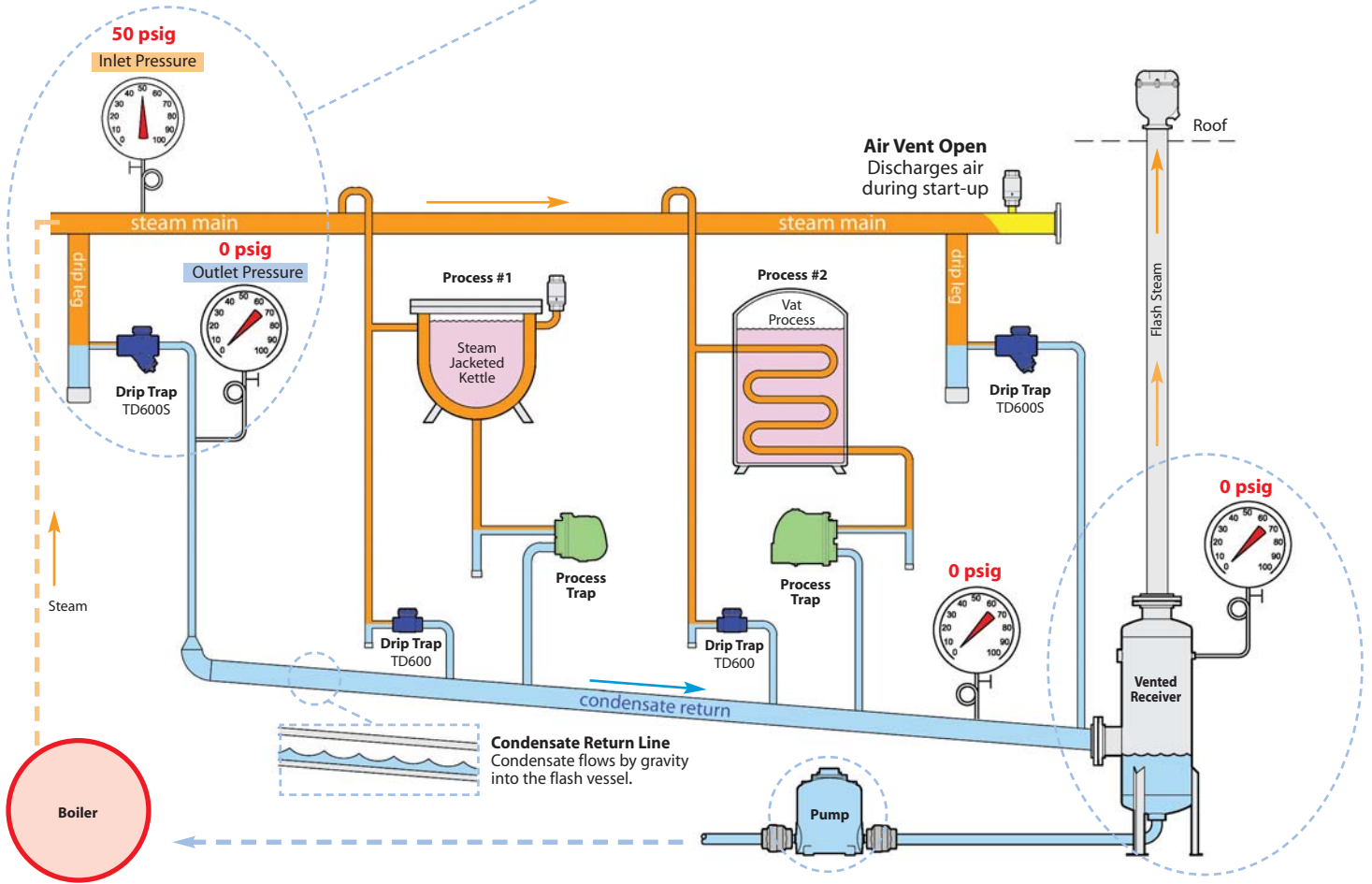
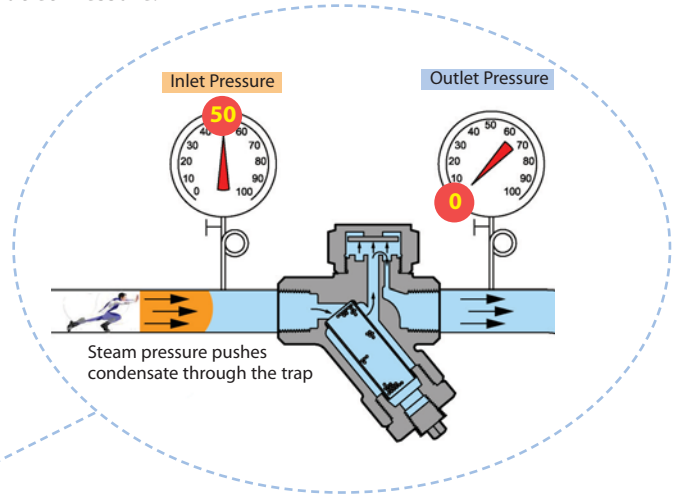

Condensate Return Pump
A mechanical or electric Pump is used to return the condensate.

Vented Receiver
A Vented Receiver maintains a pressure of **0 psig** inside the condensate return lines by venting the flash steam generated by the hot condensate to the atmosphere.

Operation of a Steam System

DRIP APPLICATION using a Thermodynamic Trap: Removing condensate from steam mains & steam supply lines

Drip applications refer to removing the condensate that forms in the steam pipes (due to heat losses) as opposed to condensate that forms at the actual process. It is appropriate to have "Drip traps" placed 150 to 300 feet apart in the steam pipe line, and at any abrupt changes in direction or elevation. Air discharges through the separate air vent located at the end of the steam line.

The Steam Trap discharges the Condensate & the Air Vent purges the air.

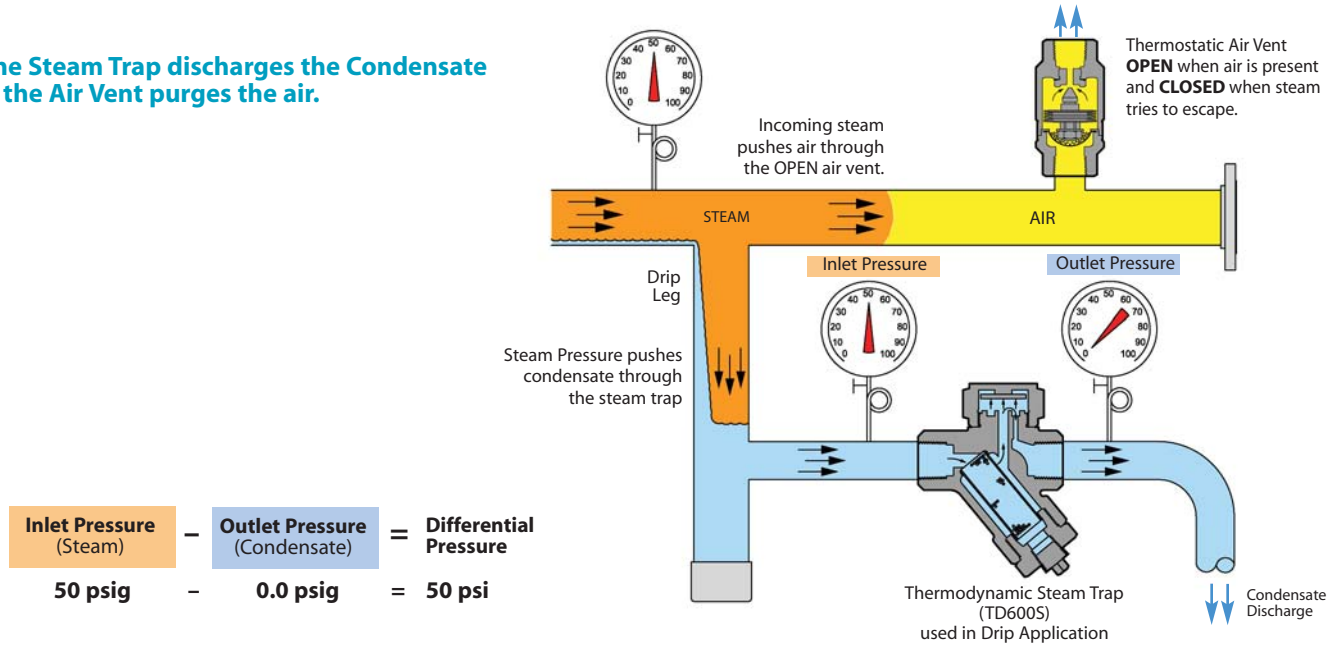

PROCESS APPLICATION using a Float & Thermostatic (F&T) Trap: Removing condensate and air from a steam jacketed kettle

Start-Up – Air discharging from system

Air that entered the system during system shut-down must be purged so that steam may enter. Float & Thermostatic steam traps contain a separate thermostatic air vent for discharging air during system start-up.

Note: Additional air vents may be installed on the process or other high points in the system.

Operation – Condensate discharging from system

Steam now fills the jacket at full operating pressure, heating the contents of kettle. Steam is condensing and the steam pressure in the kettle is being relied upon to push the condensate through the steam trap and into the condensate return line.

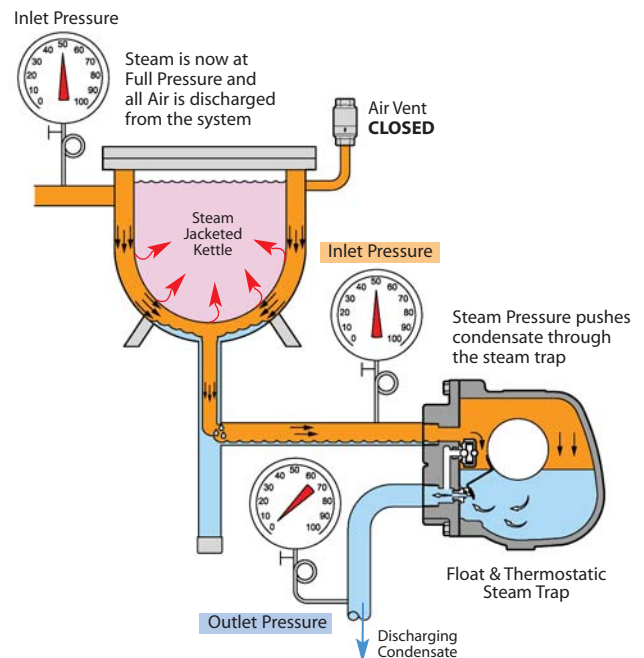
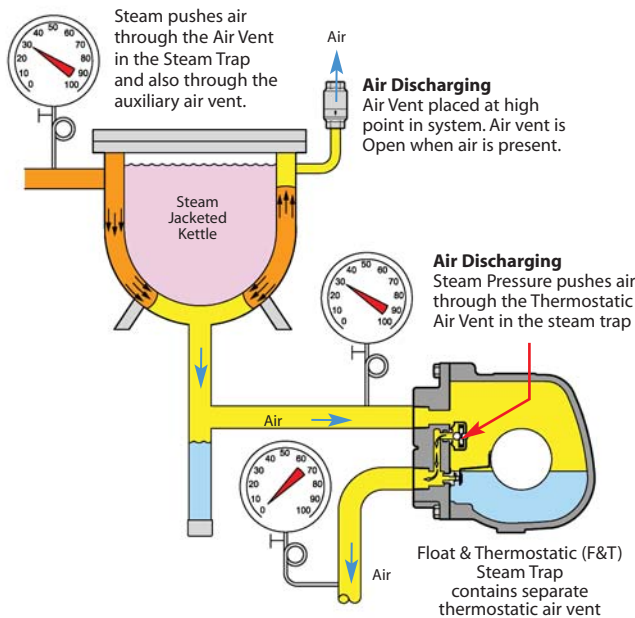

Typical Ways Steam Traps are Installed ... and how this affects the differential pressure.

Depending on the installation of the steam trap, the pressure at the outlet of the trap can vary significantly. It is important to understand the trap Outlet Pressure as this will affect the differential pressure used for sizing and selecting the appropriate steam trap. Furthermore, there could be instances where steam supply pressure to the inlet of the trap is insufficient to "push" the condensate into the return line. The following diagrams show: **1) discharging condensate to atmosphere, 2) discharging condensate into gravity return line, and 3) discharging condensate into an elevated and/or pressurized return line.**

1) Discharging Condensate to Atmosphere:

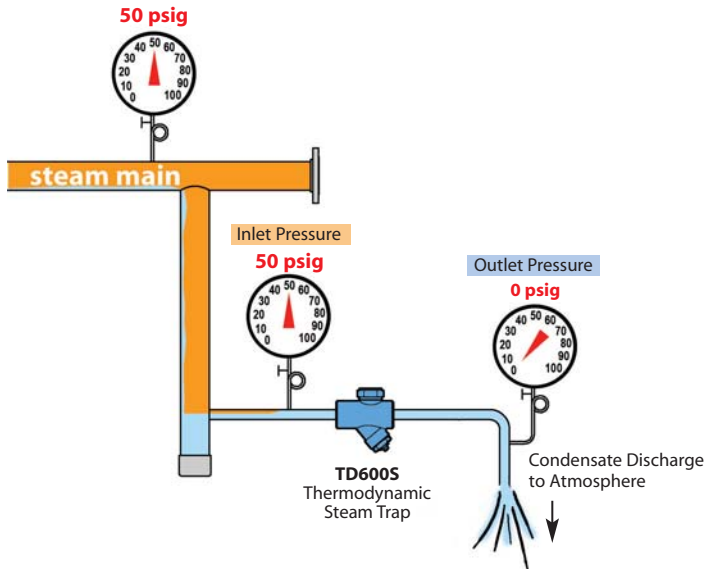

Steam Pressure "pushes" the condensate through the steam trap allowing it to discharge out of the system (0 PSIG)

Discharging condensate to atmosphere is often done in larger facilities when it may not be cost-effective or practical to install long lengths of condensate return lines back to the boiler.

Inlet Pressure: The Pressure in the steam main. In our case, **50 psig**

Outlet Pressure: Since we are discharging steam trap to atmosphere, **0.0 psig**

Inlet Pressure (Steam)	-	Outlet Pressure (Condensate)	=	Differential Pressure
50 psig	-	0.0 psig	=	50 psi

2) Discharging Condensate to Gravity Return Line (Connected to Vented Receiver):

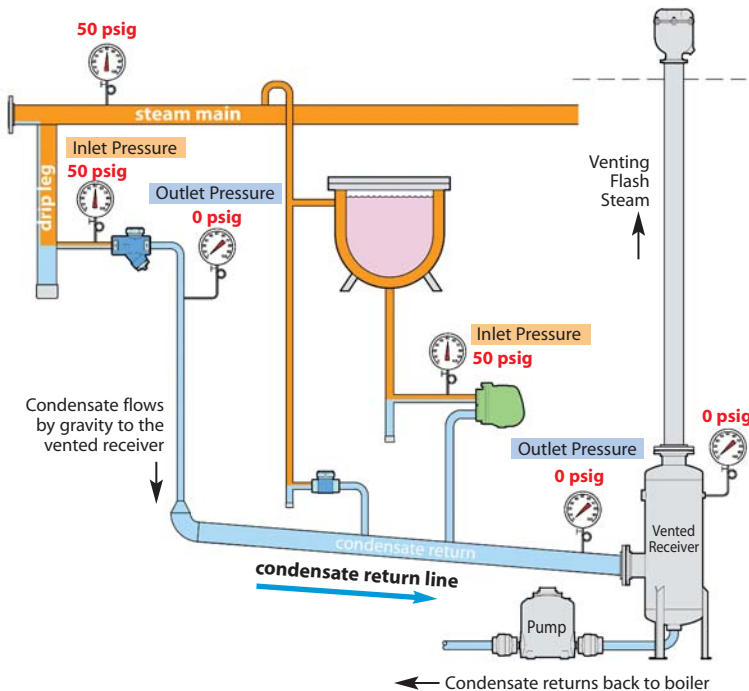

Steam Pressure "pushes" the condensate through the steam trap allowing it to discharge into gravity return line (0 PSIG)

It is always preferable to drain condensate in the direction of gravity to a condensate return line which leads into a vented receiver for condensate collection. In most situations the vented receiver vents to atmosphere, and is therefore at a pressure of 0.0 psig.

Inlet Pressure: The Pressure in the steam main. In our case, **50 psig**

Outlet Pressure: Since the steam trap is being discharged to a properly sized condensate return line that leads to a vented receiver, we assume **0.0 psig**

Inlet Pressure (Steam)	-	Outlet Pressure (Condensate)	=	Differential Pressure
50 psig	-	0.0 psig	=	50 psi

3) Discharging Condensate into an Elevated and/or Pressurized Return Line:

Condensate Return Lines are designed to drain by gravity at 0 psig; however, they often contain unintentional pressure from being undersized or from the discharge of failed steam traps.

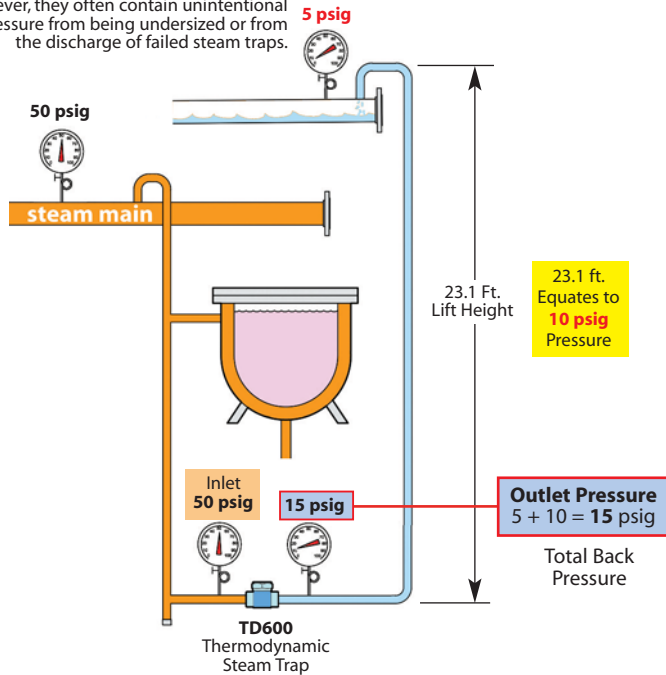

Steam Pressure “pushes” the condensate up through an Elevated return line (15 PSIG)

Total Back Pressure (Outlet Pressure) is the Sum of Condensate Return Line Pressure + Equivalent Lift Height Pressure

Discharging condensate upward against gravity is the least desirable scenario; however, in certain instances, it may be the only solution possible. Since condensate must be “lifted” to an elevation, it adds additional back-pressure to the discharge (outlet) side of the trap. For this example the condensate return line pressure is **5 psig**. We first need to calculate Lift Height Pressure :

$$\begin{aligned} \text{Lift Height Pressure} &= \text{Height} \times 0.433 \\ &= 23.1 \text{ Ft.} \times 0.433 \\ &= 10 \text{ psig} \end{aligned}$$

Inlet Pressure: Pressure in the steam main. = **50 psig**

Outlet Pressure: Since we are discharging steam trap to a pressurized and elevated condensate return line, we need to add condensate return line pressure (5 psig) to lift height pressure (10 psig) = **15 psig**

Inlet Pressure (Steam)	-	Outlet Pressure (Condensate)	=	Differential Pressure
50 psig	-	15 psig	=	35 psi

Calculating Lift Pressure

A column of condensate in vertical piping results in additional pressure at the outlet of the steam trap. By knowing the height of the condensate return line, the pressure of this column can be easily calculated as follows:

$$\text{Lift pressure (psig)} = \text{Lift height (ft)} \times 0.433 \text{ (psig/ft)}$$

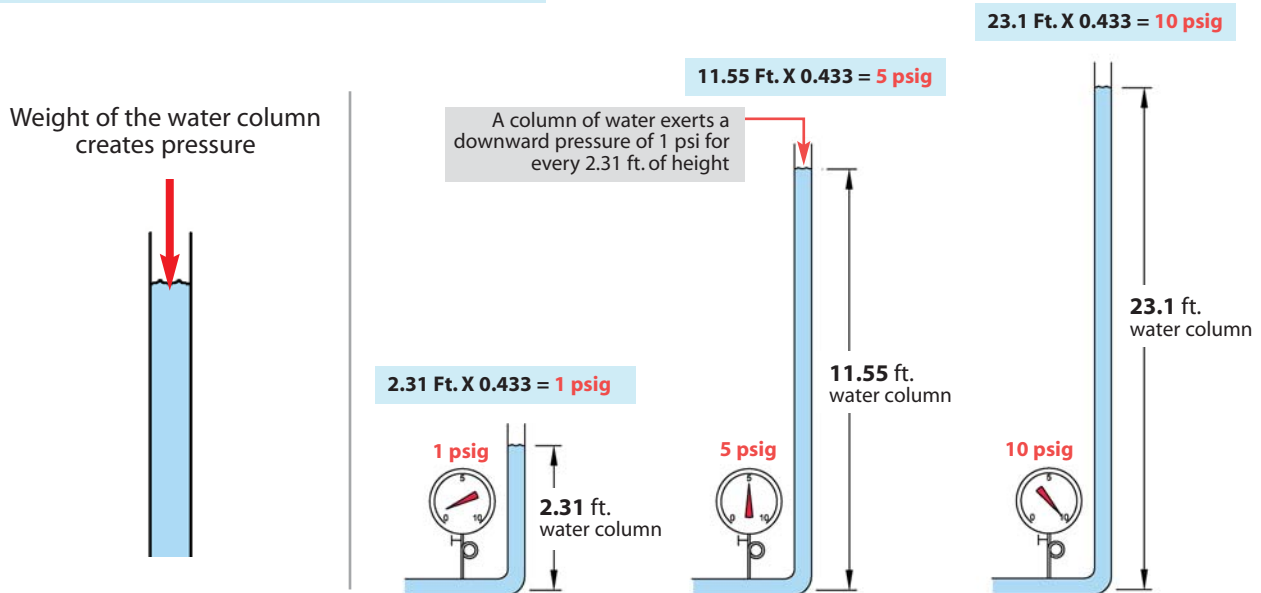

Steam Trap Installed after a Control Valve ... which can cause wide variations of trap inlet pressures and condensate loads.

The flow rate and the steam pressure in the jacketed kettle is determined by the temperature control valve. When the process fluid in the jacketed kettle reaches the desired set temperature, the control valve reduces the flow of steam which, in turn, reduces steam pressure. The Steam pressure can drop down to 0 psig or below (to sub-atmospheric pressures) to maintain just the correct amount of steam flow to keep the kettle at the exact set temperature.

With the varying amount of steam that is sent to the process, the amount of condensate that is generated also varies. If the steam demand is high for a given period, more condensate is generated after the steam is used. When there is a low steam demand, less condensate is generated.

The appropriate steam trap selected for process applications must be able to adjust to varying condensate loads without oversizing, and have the capability to remove air from the system.

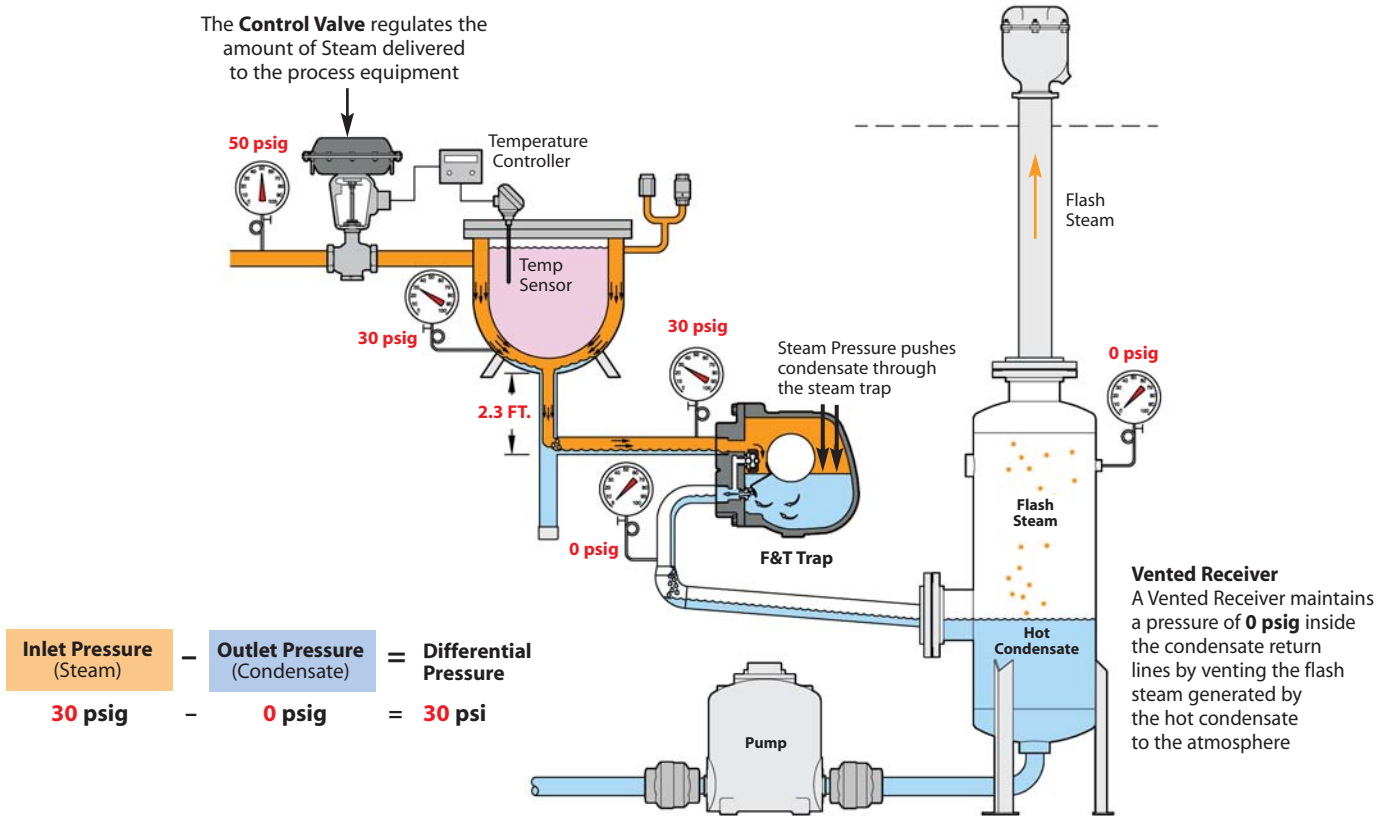

Why the Steam Trap needs to be placed a minimum distance below Jacketed Kettle

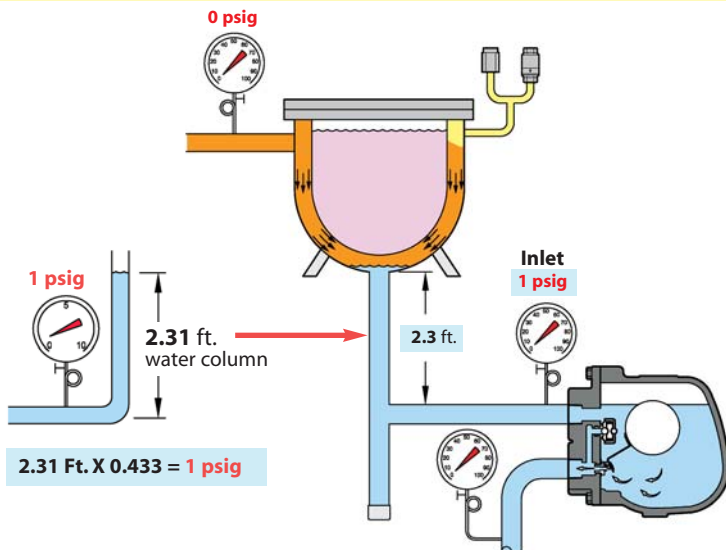

When set temperature of the process fluid is reached, the steam pressure inside the jacketed kettle may reduce to 0 PSIG or even go into Vacuum. To promote condensate drainage, the steam trap is placed a certain distance below the process equipment.

2.3 ft. will provide 1 psig of condensate head pressure. As long as the trap discharges into a gravity return line (at 0 psig), there will be 1 psi differential pressure and condensate may freely drain.

$$\text{Pressure} = \text{Column Height} \times 0.433 \frac{\text{psi}}{\text{ft}}$$

$$1 \text{ psig} = 2.31 \text{ Ft.} \times 0.433$$

Typical Process Equipment Which Use Steam for Heating

Batch Processes: Steam Jacketed Kettle

Steam jacketed kettles are used for batch processing and are typically found in commercial food processing facilities. A steam jacketed kettle contains a liquid to be heated surrounded by an isolated jacket containing the steam (steam does not contact the fluid). Steam enters the kettle and its heat is then transferred to the liquid through the jacket wall and the condensate is discharged out the bottom. Steam Pressure to the kettle is controlled by the Steam Supply (Control) Valve. The steam trap is placed a minimum distance below the kettle to promote condensate drainage when low pressure or partial vacuum exists in the jacket of the kettle (14" is equivalent to 1/2 psi of head pressure).

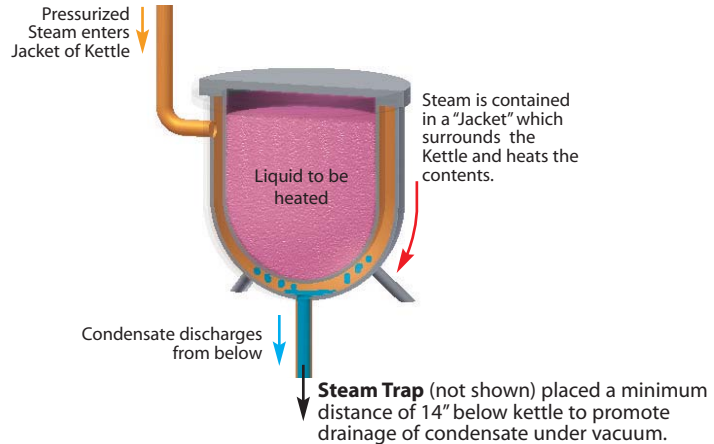

Continuous Process: Shell & Tube Heat Exchangers

Shell & Tube Heat Exchangers are used for continuous processes such as heating a continuous flow of water or other liquid. The Shell & Tube heat exchanger contains multiple tubes inside to optimize heat transfer to the process. In the majority of applications, the process liquid goes through the inside of the tubes and the steam surrounds the outside of the tubes and is contained within the shell area. The condensate that is formed from the condensed steam is discharged out of the bottom through a steam trap. Steam Pressure to the heat exchanger is controlled by the Steam Supply (Control) Valve. The steam trap is placed a minimum distance below the heat exchanger to promote condensate drainage when low pressure or partial vacuum exists in the shell of the heat exchanger (14" is equivalent to 1/2 psi of head pressure).

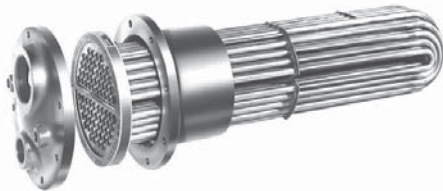

Tube Bundle of a Shell & Tube Heat Exchanger

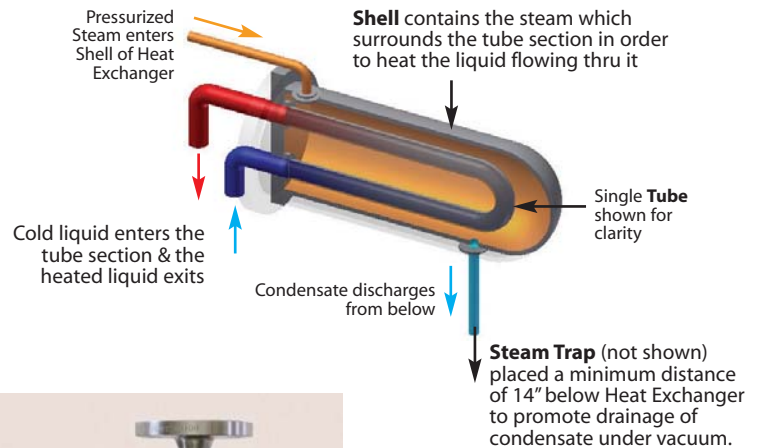

Shell & Tube Heat Exchanger

Batch Process Application: Jacketed Kettle ... from Start-Up to Reaching Temperature Set Point

Let's take a detailed look at a **batch process** application using a control valve to heat the contents of a Jacketed Kettle to a specific temperature. Steam will enter the jacket to indirectly heat the kettle contents through a metal wall.

The condensate load and pressure drop across the steam trap varies because the control valve will open and close in response to the temperature of the contents inside of the kettle. As the valve opens and closes, the **steam pressure and steam flow in the jacket** will vary, affecting the differential pressure across the steam trap and condensate load requirements. A Float & Thermostatic steam trap is the primary choice for the majority of process applications because of its ability to quickly adjust to changing condensate loads, as well as having the capability to discharge air from the system.

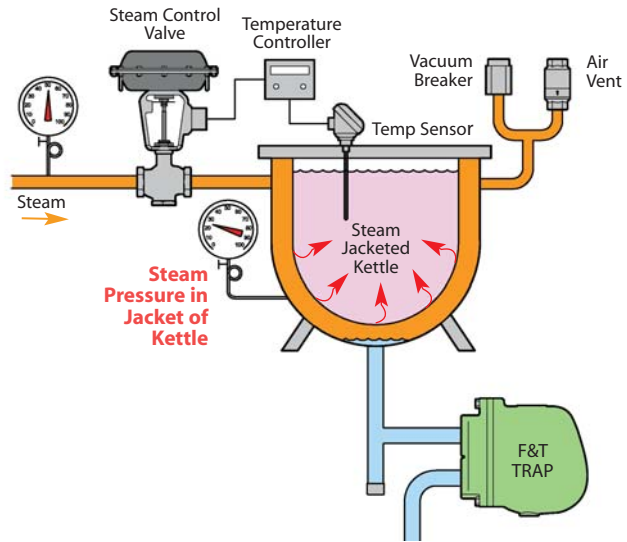
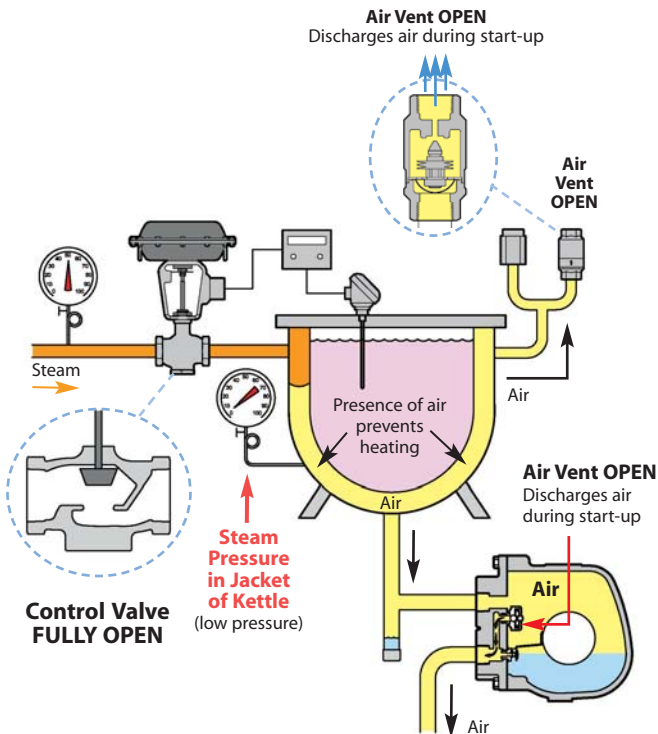

DIAGRAM 1:

Start-Up (Air Vents Open)

On start-up, jacket is filled with air which must first be discharged by the Air Vents to allow steam to enter for heating. Float & Thermostatic steam traps contain a separate thermostatic vent, and can discharge large volumes of air present during system startup. Additional air vents may be installed on the kettle. The faster air is expelled, the faster steam can enter and heating can begin.



Air Discharging from Process on Start-Up

DIAGRAM 2:

Steam Enters (Trap Fully Open; Air Vents Closed)

Once the air has been discharged, steam can fill the jacket. Since the kettle is cool, the control valve will open to allow as much steam as possible to fill the jacket and begin heating the contents in the kettle. The steam trap must adjust to the high condensate load as the steam is entering and building pressure.

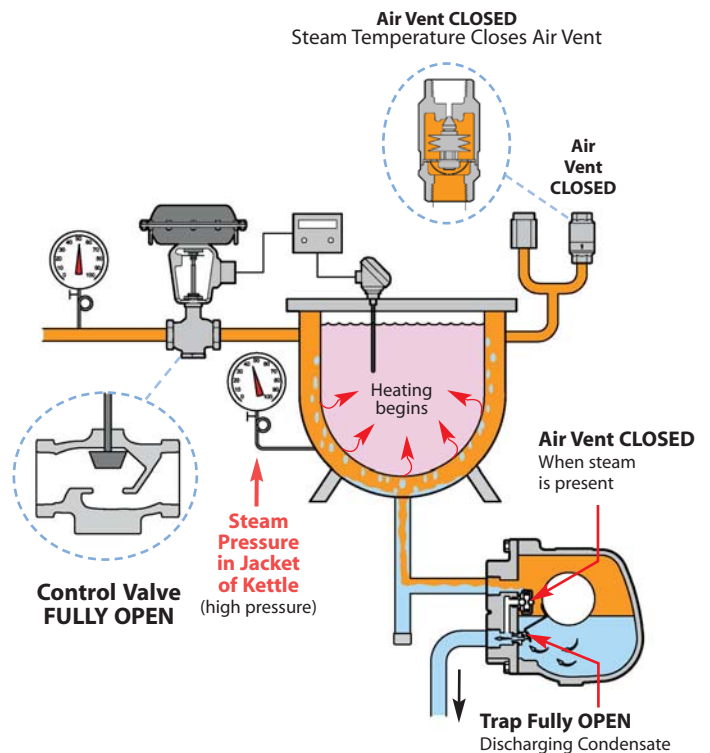

Temperature of Steam causes Air Vents to Close

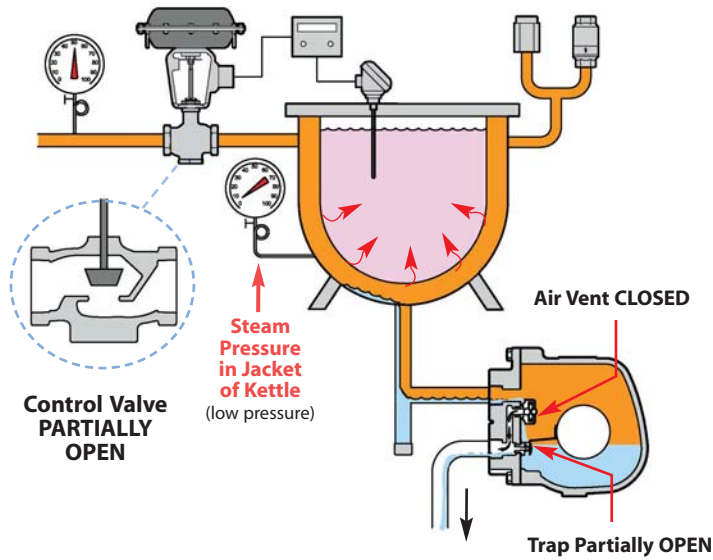

DIAGRAM 3:

Nearing Set Temperature (Trap Partially Open)

As the temperature of the kettle contents nears set point, less steam will be required and the control valve will modulate toward a partially open position. As this happens, steam pressure decreases in the jacket and therefore the pressure differential across the steam trap will likewise decrease. The steam trap will then adjust to the lower condensate flow generated.

Process Liquid is nearing Set Temperature

DIAGRAM 4:

Temperature Set Point Achieved (Steam Flow Reduced; Since Only Required to Maintain Temperature)

Once the set temperature is achieved, a significantly less amount of steam is required to maintain the temperature of the product inside the jacketed kettle. The steam supply valve will modulate to a near shut-off condition, dropping the pressure, and the kettle may be operating in vacuum. This action will impede the discharge of condensate as the pressure in the jacket will be less than atmospheric. Therefore, a vacuum breaker is required to allow air to enter the jacket and equalize the pressure. This then allows drainage of condensate through the steam trap by gravity.

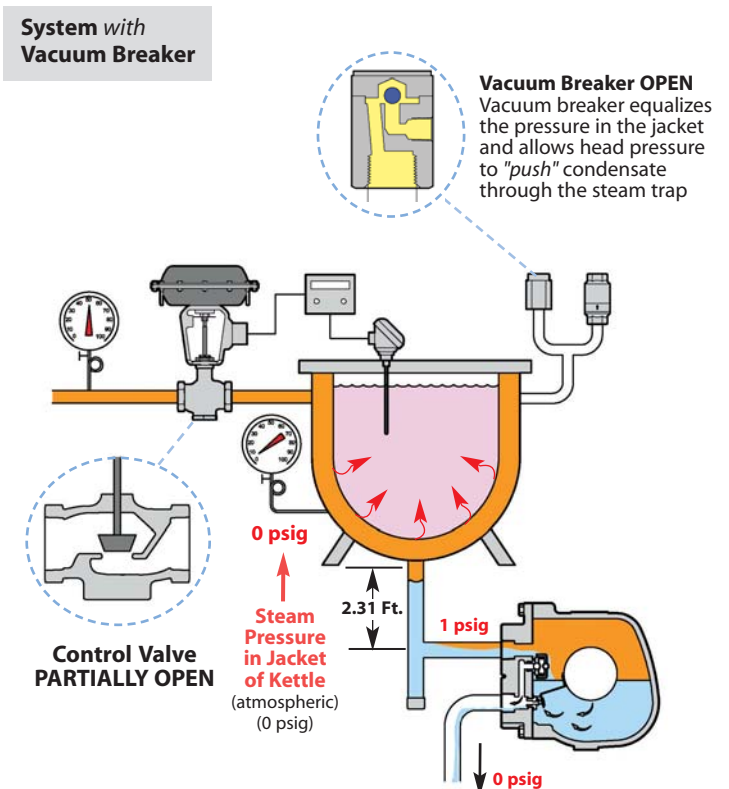
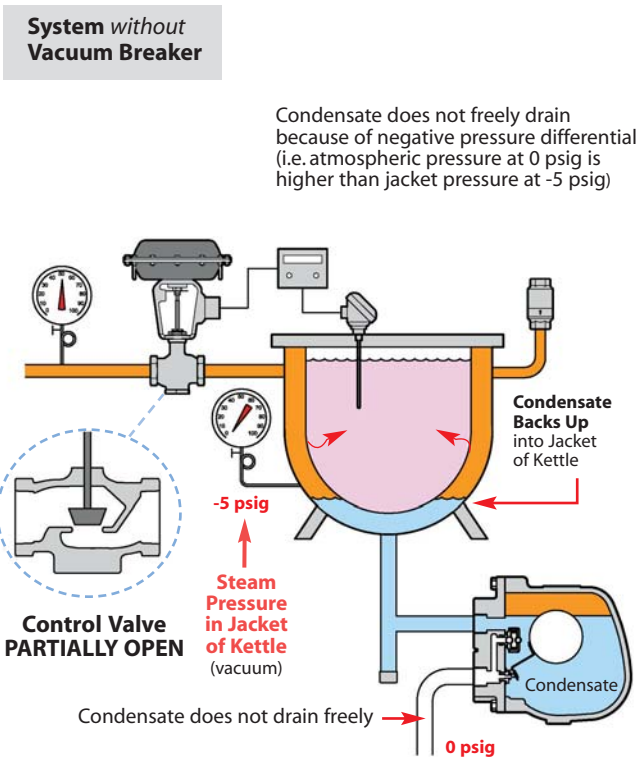

Continuous Process Application: Shell & Tube Heat Exchanger

Let's take a detailed look at a **continuous process** application using a control valve on a Heat Exchanger to heat a variable flow rate of water to a constant temperature. Cold water enters the Heat exchanger and hot water is discharged at an elevated temperature.

The condensate load and pressure drop (differential pressure) across the steam trap are not constant. Therefore, it is important to select a steam trap that can handle high condensate loads at very low pressure drops, without significantly oversizing the steam trap during normal operation.

A temperature control valve will modulate between an open and closed position to deliver the proper amount of steam to a heat exchanger to maintain the outlet water at a desired temperature. During this process, the steam pressure in the heat exchanger will vary depending on the flow rate of heated water produced. *The higher the flow rate of water – the higher the steam pressure in the heat exchanger will be. Conversely, when water flow is reduced, steam pressure is reduced.*

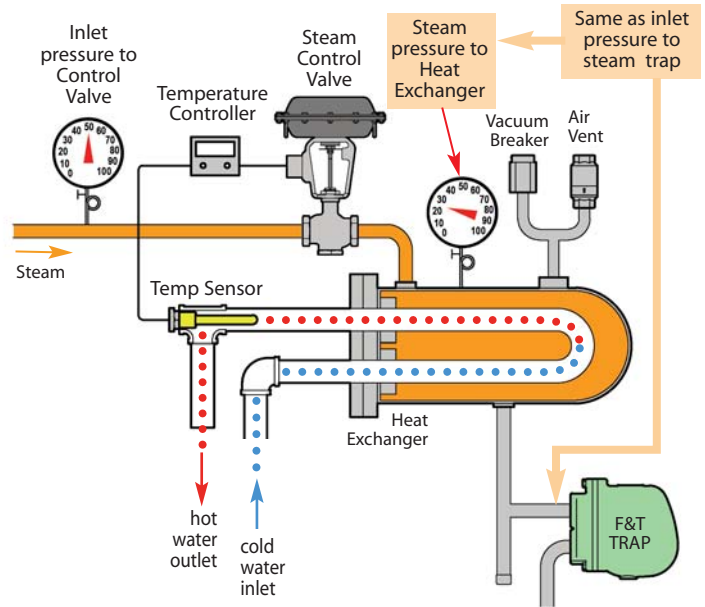

DIAGRAM 1:

Start-Up (Air Vents Open)

On start-up, heat exchanger is filled with air which must first be discharged by the Air Vents to allow steam to enter for heating. Float & Thermostatic steam traps contain a separate thermostatic vent, and can discharge large volumes of air present during system startup. Additional air vents may be installed on the heat exchanger. The faster air is expelled, the faster steam can enter and heating can begin.

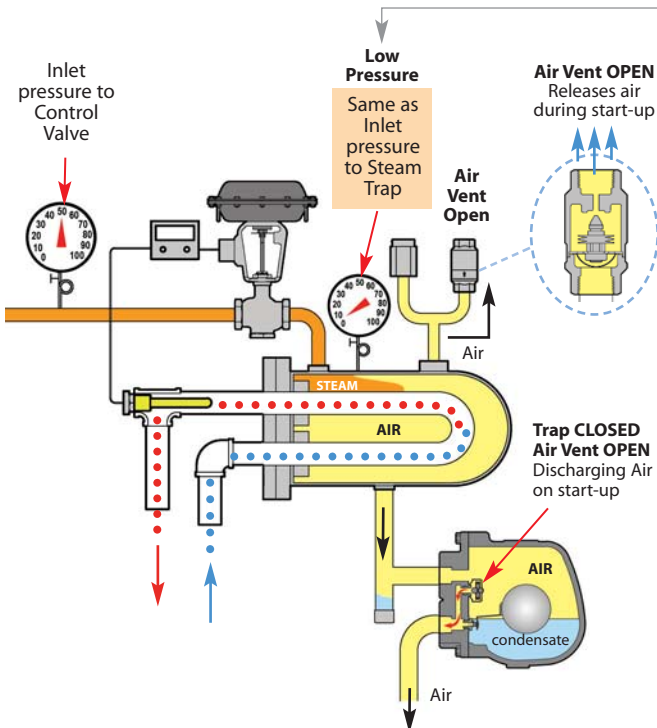

DIAGRAM 2:

Steam Enters (Trap Fully Open; Air Vents Closed)

Since the water temperature is cold, the control valve is fully open to allow as much steam as possible to fill the heat exchanger. The steam trap must adjust to the high condensate load as the steam is entering and building pressure. This steam pressure in the shell of the heat exchanger pushes the condensate through the steam trap and into the return line.

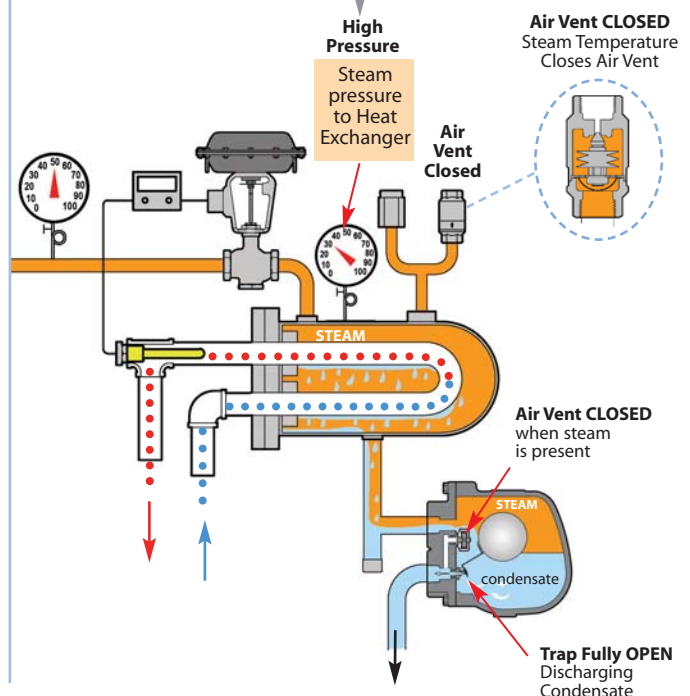

DIAGRAM 3:

Typical Running Load

The temperature control valve will automatically adjust the flow of steam (lbs/hr) to coincide with the flow rate of heated water (GPM). The higher the flow rate, the higher the steam pressure will be. The steam pressure in the shell of the heat exchanger is indirectly determined by the amount of water flowing through the heat exchanger. The steam (lbs/hr) turns into condensate (lbs/hr) and is discharged through the steam trap.

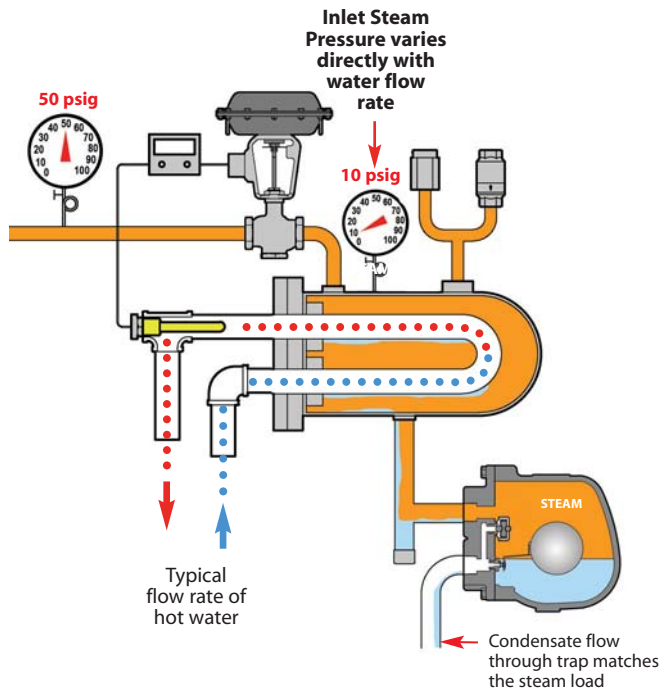

DIAGRAM 4:

High Running Load

When a high flow rate of heated water is required, the control valve will open accordingly to allow more steam (lbs/hr) and steam pressure (psi) to enter the heat exchanger. During times of high water usage, there will also be a significant increase in the condensate load (lbs/hr), as well as higher steam pressure in the shell of the heat exchanger. This high pressure steam will push the condensate through the steam trap.

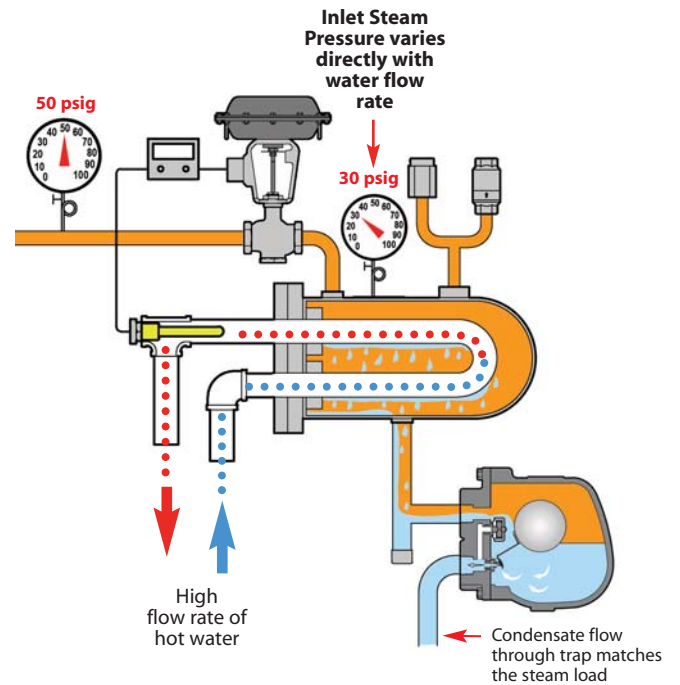
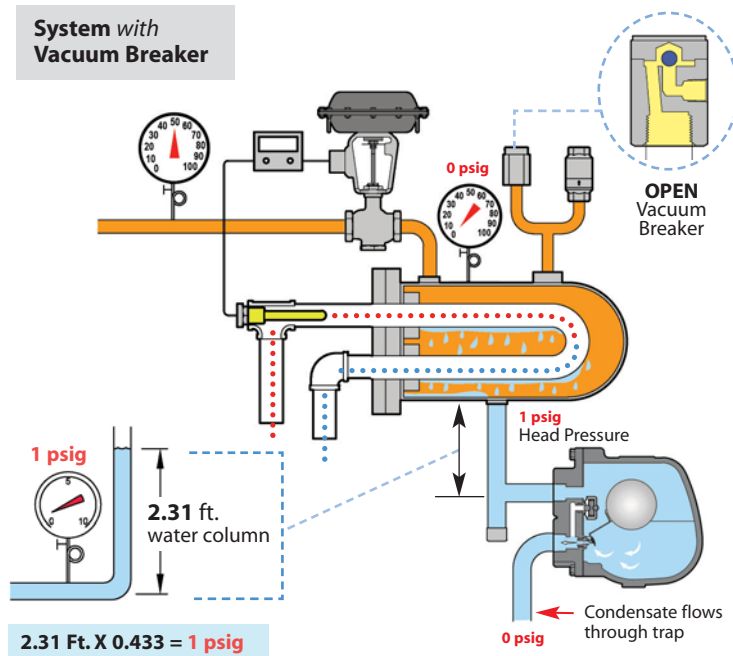

DIAGRAM 5:

Low Running Load

When the demand for hot water is low, the steam control valve will adjust accordingly, allowing just enough steam to heat the reduced flow of water. The pressure in the shell of the heat exchanger will go into vacuum, preventing discharge of condensate. Therefore, a vacuum breaker is used to allow air to enter the shell and equalize the pressure, allowing drainage of condensate through the steam trap by gravity.



System without Vacuum Breaker

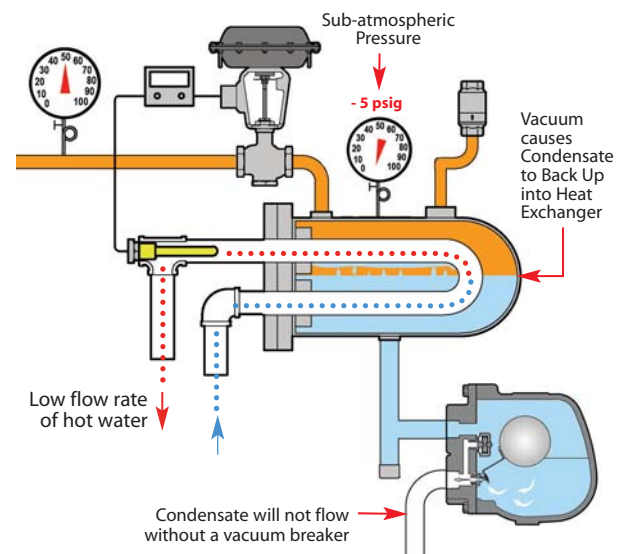

Steam Traps

Table of Contents



TD600



TD600S



TD700S



TD900S

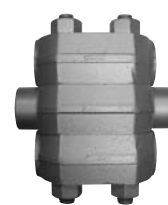

TD3600

Thermodynamic

Model	Body Material	PMO (PSIG)	Sizes	Connections	Page No.
TD600	Stainless Steel	600	3/8" - 1"	NPT	38
TD600S	Stainless Steel	600	1/2", 3/4", 1"	NPT	40
TD700S	Alloy Steel	600	1/2", 3/4", 1"	NPT, SW, FLG	42
TD900S	Alloy Steel	900	1/2", 3/4", 1"	NPT, SW, FLG	44
TD3600	Alloy Steel	3600	1/2", 3/4", 1"	SW, BW, FLG	46



WT1000



WT2500



W2000



WT3000



WT4000



WT5000



TA/TS

Thermostatic

Model	Body Material	PMO (PSIG)	Sizes	Connections	Page No.
WT1000	Stainless Steel	300	1/2", 3/4"	NPT	51
WT2000	Stainless Steel	650	1/2", 3/4"	NPT	52
WT3000	Stainless Steel	650	1/2", 3/4"	NPT, SW, FLG	54
WT4000	Stainless Steel	300	3/4", 1"	NPT, SW, FLG	56
WT5000	Stainless Steel	650	3/8" - 1"	NPT, SW	58
TA/TS	Brass	25/125	1/2", 3/4"	NPT	60
WT2500	Cast Iron	250	1/2", 3/4"	NPT	62



FT



FT600 & FT601



FTE & FTES



FTT



WFT

Float & Thermostatic

Model	Body Material	PMO (PSIG)	Sizes	Connections	Page No.
WFT	Cast Iron	250	3/4" - 2"	NPT	66
FTT	Ductile Iron	300	1/2" - 2"	NPT	70
FTE/FTES	Ductile Iron/Cast Steel	200/300	1 1/2", 2", 2 1/2"	NPT, SW, FLG	74
FT600/FT601	Carbon Steel/Stainless Steel	450	3/4" - 4"	NPT, SW, FLG	76
FT	Cast Iron	75	3/4" - 2"	NPT	82



Stainless Steel



Cast Iron

Inverted Bucket

No Strainer	Strainer	Body Material	PMO (PSIG)	Sizes	Connections	Page No.
SIB/SIBH		Stainless Steel	450	1/2", 3/4"	NPT, SW,	86-87
IB 1031	IB 1041	Cast Iron	150	1/2", 3/4"	NPT	88-93
IB 1032	IB 1042	Cast Iron	250	1/2", 3/4", 1"	NPT	88-93
IB 1033		Cast Iron	250	1/2", 3/4"	NPT	88-93
IB 1034	IB 1044	Cast Iron	250	3/4", 1"	NPT	88-93
	IB 1038S	Cast Iron	250	1 1/4", 1 1/2"	NPT	88-93



Quick-Change Universal Style

Model	Type	PMO (PSIG)	Sizes	Connection	Page No.
USIB450	Inverted Bucket	450	1/2", 3/4", 1"	Universal Connector	100
UFT450	Float & Thermostatic	225	1/2", 3/4", 1"	Universal Connector	102
UTD450	Thermodynamic	450	1/2", 3/4", 1"	Universal Connector	104-107
UTD600	Thermodynamic	600	1/2", 3/4", 1"	Universal Connector	104-105
UT450	Thermostatic	450	1/2", 3/4", 1"	Universal Connector	108
UB450	Bi-Metallic	450	1/2", 3/4", 1"	Universal Connector	110

Clean Steam



Model	Body Material	PMO (PSIG)	Sizes	Connections	Page No.
FDA300	Stainless Steel	90	1 1/2"	Tri-Clamp	113
FDA400	Stainless Steel	90	1/2", 3/4"	Tri-Clamp	114
FDA500	Stainless Steel	90	1/2", 3/4", 1"	Tri-Clamp, NPT, TW	116
FDA600	Stainless Steel	110	1/2", 3/4", 1"	Tri-Clamp, NPT, TW	118
FDA800	Stainless Steel	150	1/2"	Tri-Clamp, NPT, TW	119

Bi-Metallic



Model	Body Material	PMO (PSIG)	Sizes	Connections	Page No.
WPN-40	Carbon Steel	470	1/2" - 2"	NPT, 150# / 300# FLG, SW, BW	120
WPN-63	Alloy Steel	823	1/2", 3/4", 1"	NPT, 300# FLG, SW, BW	120
WPN-100	Alloy Steel	1220	1/2", 3/4", 1"	NPT, 600# FLG, SW, BW	120
WPN-160	Alloy Steel	1620	1/2", 3/4", 1"	NPT, 900# FLG, SW, BW	120
WPN-250	Alloy Steel	2260	1/2", 3/4", 1"	NPT, 1500# FLG, SW, BW	120



Manifolds

Page 126

The **FM / FSM Series Manifolds** are used for steam distribution to the tracing system and for condensate collection.

Steam Trap Selection Guidelines

Steam Traps for Drip Applications: “Drip traps”

Drip applications refer to draining condensate that forms in distribution piping as steam is transported from the boiler to where it is to be used. Eliminating this condensate protects valves and piping from wiredrawing and water hammer. Because condensate loads tend to be low, steam traps with smaller orifices are typically selected for extended service life. It is reasonable to consider a single trap that can operate over a wide pressure range in order to simplify selection and reduce inventory. Other factors to consider when selecting drip traps: materials, reparability, efficiency, reliability, installation orientation, personal preference/experience, as well as the trap’s ability to handle freezing climates, superheated steam, or pipe scale and debris.

Steam Traps for Tracing Applications: “Tracing Traps”

Tracing Applications refer to using steam to elevate the temperature of a product, process, or piece of equipment by using tubing or some type of jacketing device filled with steam. These applications are commonly used to promote flow of heavy fluids or prevent pipelines and equipment from freezing. The relatively small traps used for these applications are referred to as “Tracing traps”. A Non-Critical Tracing application may benefit from a thermostatic steam trap which sub-cools and backs up some condensate - an adjustable bimetal trap offers additional temperature control. Thermodynamic traps are ideal for Critical Tracing applications where condensate back-up is not permitted.

Steam Traps for Process Applications: “Process Traps”

Process applications refer to draining condensate from the actual process using the steam. These require steam traps with relatively high condensate capacity. In the majority of process applications, it is important to discharge air present in the system during start-up so the steam can quickly enter the system. Although separate air vents can be used for this purpose, it makes sense to select a trap which has air venting capability, in addition to discharging varying condensate loads. The trap must have enough capacity to discharge the condensate even when the differential pressure across the trap is low. These low pressure conditions commonly occur in process heating applications where control valves are used to regulate the flow of steam into the equipment. However, if the trap is significantly oversized it may cause it to wear out more quickly and allow steam to pass into the condensate return. The most common trap type for process applications is the Float & Thermostatic style.

Most Common Types of Steam Traps

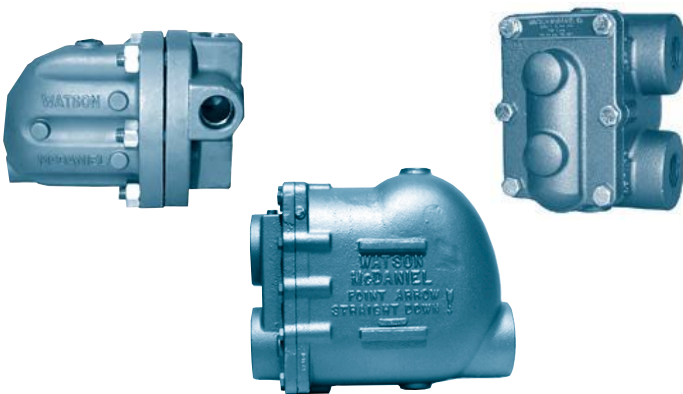

Most Common Use:

Process Applications from low pressure HVAC models for residential heating to Industrial cast steel and stainless steel models for Chemical and Petro-Chemical plants up to 450 PSI. Suitable alternative for drip applications to 200 psig.

F&T (Float & Thermostatic) Traps:

Float & Thermostatic Steam Traps contain a float-operated valve to continually discharge condensate and a thermostatic air vent which discharges air. Body materials available are Cast Iron, Ductile Iron, Cast Steel, & Stainless Steel for pressures up to 450 psig. (F&T traps are referred to as mechanical traps.)

Typical Applications: F&Ts are the most commonly used trap for both batch type processes and continuous process applications with rapidly changing pressures and loads.

Advantages: F&Ts quickly respond to load and pressure changes, discharge large amounts of air present at start-up which allow steam to quickly enter the system, continuously discharge condensate as it forms and offer a wide range of capacities for any process application.

Other Factors to Consider: F&Ts narrow operating pressure ranges require more care during selection. Since they are not self-draining, they are subject to freezing. Trap body must be installed vertically for proper operation.

Steam Trap Selection Guidelines



Most Common Use:
General service drip & tracing applications above 30 psig, as well as high-pressure drip applications with superheat.

Thermodynamic Traps:

The Thermodynamic Trap is simple and compact with a single moving part (disc) which opens to discharge condensate and closes in the presence of steam. Body materials available are Stainless and Alloy Steels for pressures up to 3,600 psig.

Typical Applications: Widely used on higher pressure drip applications and critical tracing applications (where condensate back-up is not permitted).

Advantages: Rugged design, operation is easy to check due to distinct cyclic operation, relatively small with lower capacities, single model operates over wide pressure range in contrast to mechanical traps, excellent for superheated steam, self-draining when mounted vertically to prevent freezing.

Other Factors to Consider: Limited air venting, wet climates can increase cycle rates, sensitive to excess back pressure, blast discharge may not be preferred in some systems



Most Common Use:
Industrial style Thermo-Static Traps are extremely versatile. Their use can range from general service drip & tracing applications to small-to-medium batch process heating applications.

Thermo-Static Traps:

A Thermo-Static Trap contains a heavy-duty, industrial-purpose welded stainless steel thermal element designed to control condensate discharge by sensing the temperature difference between steam and cooler condensate. Body materials available are Cast Iron, Stainless and Alloy Steels with thermal element designs available for pressures up to 650 psig. The WPN Series Bi-metallic design will handle pressures up to 2,260 psig.

Typical Applications: Extremely versatile and energy efficient, these traps are suitable for a wide range of applications. Thermal element designs are suitable for applications ranging from general service drip and tracing applications to small-to-medium batch style processes. Bi-metal designs can be used in high pressure, superheated drip applications or in lower pressure tracing applications.

Advantages: Self-draining when mounted vertically to prevent freezing, single model operates over wide pressure range in contrast to mechanical traps, small and compact with similar capacities to larger mechanical traps (F&Ts & IBs), superior air venting capabilities, welded stainless steel thermal element and bimetal elements are extremely rugged, moderate discharge due to reduced flash steam, choose between fail-open or fail-closed bellows.

Other Factors to Consider: Some condensate back-up can be expected, thermal element design not recommended for superheated applications.



Most Common Use:
Used on drip applications where excessive dirt and debris may be of significant concern. They can serve as alternatives to F&T's in process applications where air venting is not required by the steam trap.

Inverted Bucket Traps:

The Inverted Bucket Trap uses an inverted bucket as a float device to control the opening and closing of the plug and seat to discharge condensate. Body materials available are Cast Iron and Stainless Steel for pressures up to 450 psig. (IB traps are referred to as mechanical traps.)

Typical Applications: These traps have a discharge orifice positioned at the top of the trap body which make them ideal for drip applications on systems containing excessive pipe scale and debris. They may be considered for process applications where air venting is less of a concern or handled by a separate air vent.

Advantages: Rugged and simple design, top-mounted discharge orifice less susceptible to failure from dirt and debris, service life often exceeds other style traps.

Other Factors to Consider: Limited air venting capabilities, can lose its prime causing it to fail, narrow operating pressure ranges require more care during selection, not self-draining therefore subject to freezing, single position installation, fixed orifice on bucket allows small steam leakage, physical size can be large and require additional support.

DRIP Applications • Sizing a Trap for Draining a Steam Main

Drip applications refer to the removal of condensate formed in steam lines due to the radiant heat loss of the hot steam pipes to surrounding air and are required for the protection of the steam system. (Drip Traps remove the condensate from the steam lines where the process traps remove condensate being generated by the actual process.) Drip traps should be placed 150 to 300 feet apart on straight runs of piping, before elevation changes, and before critical equipment such as Regulators and Control Valves. See description below of typical drip leg configurations.

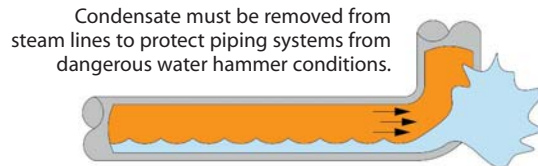
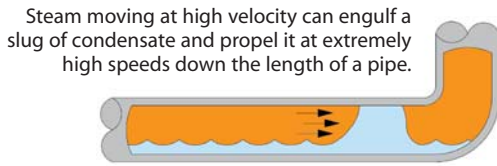

Why Condensate Safety Load Factors and Warm-up Loads need to be considered:

During start-up, when the piping system is cold and steam begins to flow thru the pipes, steam is condensing very quickly because of the energy required to heat all the cold surfaces. Furthermore, the steam pressure in the system which is required to push the condensate through the steam trap into the return line, is low before the system comes up to full pressure. Therefore, condensate is being generated at a maximum rate and the steam pressure used to push the condensate out of the system is at a minimum. If the traps are sized for the normal running loads and normal system pressures, then they would be undersized for the start-up condition.

In a supervised start-up, condensate drain valves located throughout the system, are manually opened to drain excessive condensate generated by the cold piping system; relying less on the steam traps. Therefore, the steam traps selected for a system with a supervised start-up can be more closely sized for the actual normal running load.

Drip Leg in a Steam Main

Drip Leg Design Criteria:

- For systems with automatic start-up, L to be 28" minimum (= 1 PSI minimum head pressure)
- Drip leg diameter should be equal to steam main diameter (up to 4" in size)

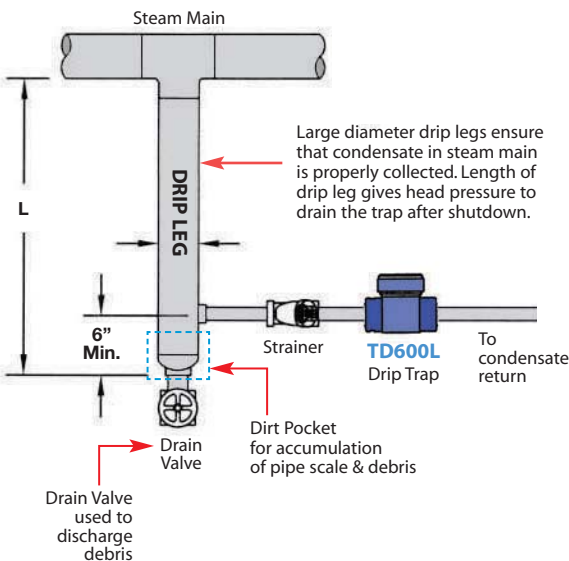

Drip Leg Before Regulator or Control Valve

Drip Legs should be installed directly ahead of regulators and control valves to minimize erosion to valve trim and flooding of valve bodies.

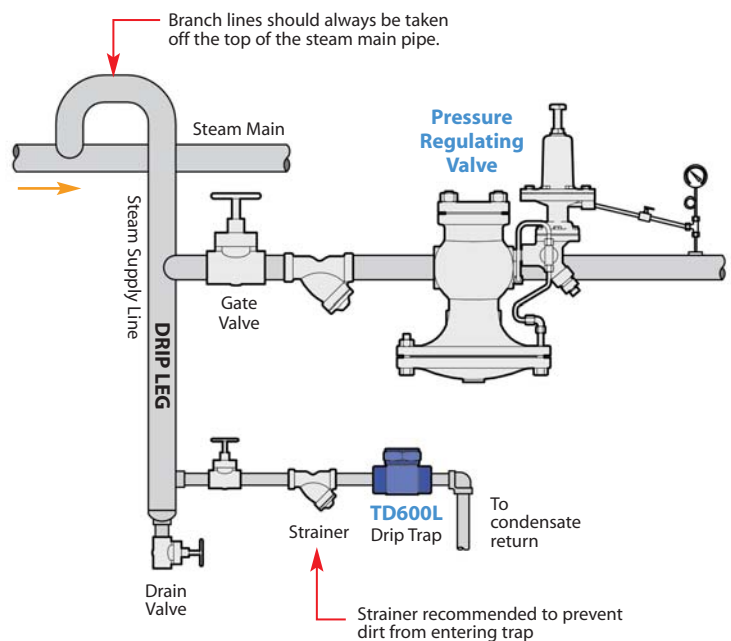

Steam Trap Selection Guidelines • DRIP Applications

Sizing Example: Size a drip trap for an 8" steam main with 100 psig steam pressure. Traps should be placed every 200 ft. A 2x safety factor based on Warm-Up load will be used.

- Based on Warm-Up Load Chart: **100 lbs/hr** of condensate is generated per 100 feet length of pipe.
- Warm up load for 200 ft. length is therefore, **200 lbs/hr** (2 x 100 lbs/hr)
- If a 2x safety factor based on warm-up load is used, we require a trap with a capacity of **400 lbs/hr**
- Actual running load for 100 ft. length = 41 lbs/hr
- Actual running load for 200 ft. length = **82 lbs/hr**

Warm-Up Loads in Pounds of Condensate per hour per 100 ft. of Steam Main

Outside Temperature at 70°F															
Steam Pressure (PSIG)	Pipe Size														0°F Correction Factor †
	2"	2 1/2"	3"	4"	5"	6"	8"	10"	12"	14"	16"	18"	20"	24"	
20	8.4	13.4	17.5	24.9	33.8	44	66	93	124	146	191	241	284	396	1.37
60	11.0	17.5	22.9	32.6	44	57	86	122	162	192	250	316	372	518	1.29
100	12.8	20.3	26.6	37.8	51	67	100	142	188	222	290	366	431	600	1.26
125	13.7	21.7	28.4	40	55	71	107	152	200	238	310	391	461	642	1.25

Running Loads in Pounds of Condensate per hour per 100 ft. of Steam Main

Outside Temperature at 70°F															
Steam Pressure (PSIG)	Pipe Size														0°F Correction Factor †
	2"	2 1/2"	3"	4"	5"	6"	8"	10"	12"	14"	16"	18"	20"	24"	
20	8	9	11	14	17	20	26	32	38	42	48	51	57	68	1.50
60	10	12	14	18	24	27	33	41	49	54	62	67	74	89	1.45
100	12	15	18	22	28	33	41	51	61	67	77	83	93	111	1.41
125	13	16	20	24	30	36	45	56	66	73	84	90	101	121	1.39

† For outdoor temperatures of 0°F, multiply load value selected from table by correction factor shown.

Trap Selection: Reference the TD600S Series Capacity Chart below based on inlet steam pressure. Enter the chart under 100 psig inlet pressure to compare the capacities of different models.

The 1/2" TD600LS will be capable of discharging 375 lbs/hr of condensate at 100 psig steam pressure. The capacity is slightly less than the load calculated based on warm-up load with 2x safety factor, however, this trap selection would be a suitable choice since its capacity is well in excess of what is actually required. These loads are indicative of drip applications and lend support as to why only reduced capacity 1/2" TD600L or 3/4" TD600L traps are required for the majority of drip applications.

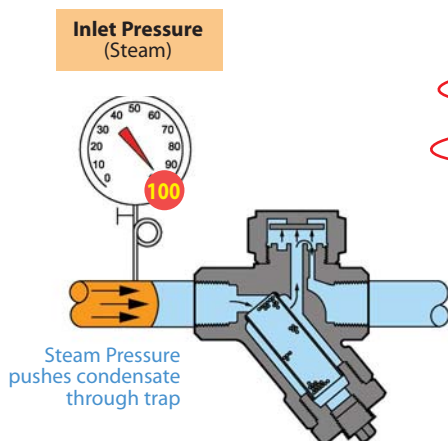

CAPACITIES – Condensate (lbs/hr)												
Size	Model Code	Steam Inlet Pressure (PSIG)										
		3.5	5	10	15	20	25	30	40	50	75	100
1/2"	TD600LS-12-N	180	185	190	195	200	215	220	230	250	310	375
1"	TD600LS-14-N	300	315	350	380	415	440	470	515	580	710	825
3/4"	TD600LS-13-N	300	315	350	380	415	440	470	515	580	710	825
1/2"	TD600S-12-N	415	430	475	520	565	610	650	720	825	1020	1185
3/4"	TD600S-13-N	415	430	475	520	565	610	650	720	825	1020	1185

Drip Applications

The trap models in the chart below are for drip applications for the protection of steam mains and steam supply lines. When traps listed below are installed every 200 feet, they will have adequate capacity to handle typical warm-up loads in properly insulated 8" steam mains. See Warm-up Load Chart in Engineering Section. Several models listed will handle steam mains considerably larger than 8". Steam pipe size, the distance between traps, insulation quality, ambient temperatures and start-up conditions should all be considered. Consult factory if additional guidance is required.

Thermodynamic		Float & Thermostatic		Thermostatic		Inverted Bucket	
Model	Size	Model	Size	Model	Size	Model	Size
30 PSIG							
30 to 150 PSIG		0 to 125 PSIG		0 to 650 PSIG		0 to 150 PSIG	
<p>Non-Repairable</p> <p>TD600L & TD600LS 1/2" 3/4"</p> <p>Repairable</p> <p>TD700S 1/2" • 3/4"</p> <p>Universal Quick-Change</p> <p>UTD450LSM</p>		<p>Parallel Pipe Connection (Cast Iron)</p> <p>WFT-125 PMO=125 3/4"</p> <p>In-Line Pipe Connection (Ductile Iron)</p> <p>FTT-145 PMO=145 1/2" • 3/4"</p> <p>Universal Quick-Change</p> <p>UFT450-145 PMO=145</p>		<p>Repairable (Cast Iron)</p> <p>WT2501 1/2" 3/4"</p> <p>(Limited to 250 PSI)</p>		<p>Cast Iron</p> <p>IB1031-150 1/2" 3/4"</p> <p>PMO=150</p> <p>Stainless Steel</p> <p>SIB150 1/2" 3/4"</p> <p>PMO=150</p> <p>Universal Quick-Change</p> <p>USIB450-150 PMO=150</p>	
125 PSIG							
150 PSIG		125 to 225 PSIG		0 to 650 PSIG		150 PSIG	
150 to 600 PSIG		125 to 225 PSIG		0 to 650 PSIG		125 to 250 PSIG	
<p>Non-Repairable</p> <p>TD600L & TD600LS 1/2" 3/4"</p> <p>Repairable</p> <p>TD700HS 1/2" 3/4"</p> <p>Universal Quick-Change</p> <p>UTD600LSM</p>		<p>In-Line Pipe Connection (Ductile Iron)</p> <p>FTT-225 PMO=225 1/2" • 3/4"</p> <p>Universal Quick-Change</p> <p>UFT450-225 PMO=225</p>		<p>Non-Repairable (Stainless Steel)</p> <p>WT2001 1/2" 3/4"</p> <p>Repairable (Stainless Steel)</p> <p>WT3001 1/2" 3/4"</p> <p>Universal Quick-Change</p> <p>UT450 (Limited to 450 PSI)</p>		<p>Cast Iron</p> <p>IB1032-250 PMO=250 1/2" • 3/4"</p> <p>Stainless Steel</p> <p>SIBH-250 PMO=250 1/2" • 3/4"</p> <p>Universal Quick-Change</p> <p>USIB450-250 PMO=250</p>	
225 PSIG							
600 PSIG							
600 - 900		600 PSIG		650 PSIG		250 PSIG	
<p>Repairable</p> <p>TD900S 1/2", 3/4"</p> <p>TD900LS (Light Loads)</p>		<p>NOTE:</p> <p>The WFT-125, FTT-145 and FTT-225 have adequate capacity for draining steam mains and steam supply lines.</p> <p>For pressures below 65 PSI, the WFT-075 or the FTT-065 can be used if a larger discharge orifice and increased capacity is required.</p>		<p>NOTE:</p> <p>IB Models up to a PMO of 250 shown above, have adequate capacity for draining steam mains and steam supply lines.</p> <p>On lower pressure systems, models with lower PMO ratings can be used if a larger discharge orifice and increased capacity is required.</p>			
900 PSIG							

Steam Trap Selection Guidelines • DRIP Applications

Thermodynamic

The Thermodynamic Disc (TD) Steam Trap is simple and compact and one of the primary choices for drip applications over 30 psig. The TD600 Series with integral one piece body-seat design, are the most economical and commonly used for pressures up to 600 psig. The 1/2" & 3/4" TD600L will meet the capacity needs of most drip applications ("S" models have integral strainers). The TD600 Series cannot be welded in-line. The TD700S & TD900S Series are both in-line repairable and can be welded into the pipeline.

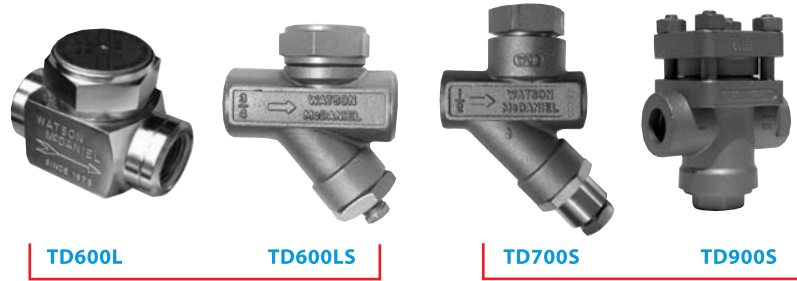

TD600L

TD600LS

TD700S

TD900S

Fully In-line Repairable

Float & Thermostatic

The Float & Thermostatic (F&T) Steam Trap is the primary choice for process applications. However, for drip applications, they can be effectively used for pressures up to 125 psig on the WFT Series & 225 psig on the FTT Series; for higher pressures, the larger body sizes required make F&T traps a less economical and desirable solution for drip service. The 3/4" WFT-125, or 1/2" & 3/4" FTT-225 will meet the capacity needs of most drip applications. Other PMO (maximum operating pressure) ranges available. For drip applications, select a PMO that meets or exceeds the maximum pressure in the main steam distribution piping.

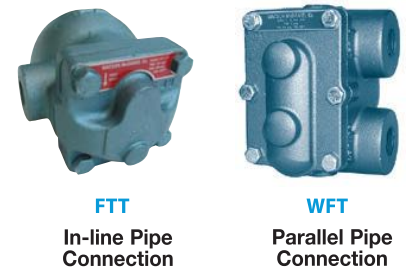

FTT

WFT

In-line Pipe Connection

Parallel Pipe Connection

Thermostatic

Thermostatic Steam Traps are extremely versatile and can be used on a wide variety of applications from general service drips to small-to-medium batch type processes. Using a welded stainless steel thermal element to control condensate discharge, these traps allow condensate to subcool, making them extremely energy efficient. As a result, the condensate discharged generates less flash steam which reduces back pressure build-up in condensate return lines. A single model will operate from 0 to 650 psig which simplifies selection. The WT2001, with stainless steel body and non-repairable design, is the most commonly used. The WT3001 and WT2501 have the same internals as the WT2001, however, their 4-bolt cover allows them to be in-line repairable. The WT3001 has a stainless steel body while the WT2501 is cast iron.



WT2501

WT2001

Repairable
(Cast Iron)

Non-Repairable
(Stainless Steel)

The WPN Series (not shown), uses a bi-metal element suitable for pressures to 2,260 psig, and will handle superheated steam.

Inverted Bucket (IB)

Inverted Bucket Traps are extremely rugged and have a discharge orifice mounted at the top of the trap body, making them less susceptible to failure from dirt and debris when compared to other trap types. The IB models selected are suitable choice for most drip applications.



Stainless Steel

Cast Iron

Universal Quick-Change

The all stainless steel universal style steam traps feature a permanent installation of the universal connector with a 2-bolt mounting arrangement for the universal steam trap module, allowing the steam trap to be removed and replaced in minutes. These Quick-Change Steam Traps should be considered for all drip applications.



- Thermodynamic
- Float & Thermostatic
- Thermostatic
- Inverted Bucket

Tracing Applications

Steam tracing refers to using steam to indirectly elevate the temperature of a product or process by using tubing or some type of jacketing device filled with steam. In a typical steam tracing application, stainless steel or copper tubing is filled with steam and is coiled or wrapped around the outside of a pipe or tank containing material that requires heating. The steam inside the tubing transfers its heat to the material in the pipe or tank; to stop it from freezing or to lower its viscosity to allow it to flow more easily. A steam trap is required for tracing to remove the condensate and air from the system. The most common trap choice for tracing applications is the Thermostatic type. Depending on the particular tracing application, it is often desirable to have some amount of condensate backup in the tubing.

Steam Tracing Applications:	Primary Trap Choice	Special Notes
Typical Service: Some condensate back-up preferable	• Thermostatic	Thermostatic traps are suitable for the majority of steam tracing applications; for critical steam tracing applications, where no back-up of condensate can be tolerated, thermodynamic traps should be used.
Critical Service: No back-up of condensate permitted	• Thermodynamic	

Heating Vertical Pipelines

Tubing can be wrapped around the piping with a steam trap installed at the low point to allow condensate to freely drain by gravity. Partial back-up of condensate using thermostatic trap.

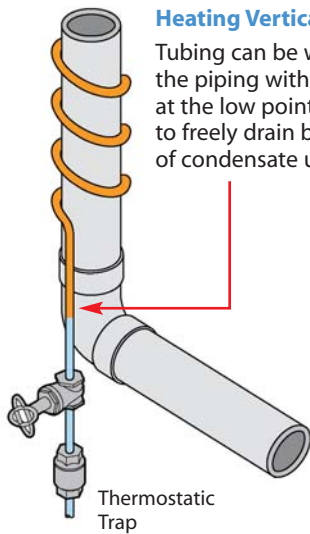

Heating Horizontal Pipelines

Tubing should not be wrapped around horizontal pipelines or condensate will collect at low points. After shutdown, condensate retained in the system could potentially freeze. Therefore, tracing tubing should be run parallel to any piping and sloped slightly towards the steam trap to promote condensate drainage.

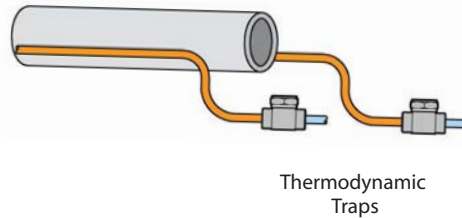

Bi-Metal Steam Trap with Adjustable Discharge Temperature (WT5000)

For applications where overheating of product fluids in a pipeline may be a concern, an Adjustable Bi-Metal Steam Trap, such as the WT5000 (shown), should be considered. The discharge temperature of the condensate can be manually adjusted to control the amount of condensate back-up in the tracing tubing. This technique can be used to control the temperature of the product in the pipeline.

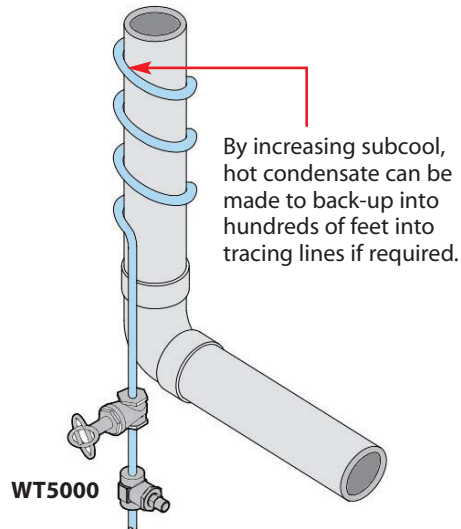

Process Steam Trap Selection Guidelines

This guide is intended to provide the user with a "starting point" for the selection of Watson McDaniel steam traps. Steam trap selection can appear to be overwhelming given the range of applications and trap choices available. Selection criteria for a specific application may include pressure & temperature ratings, capacity, physical size & weight, and materials.

Batch Process - Steady Demand

Batch type processes typically have steady demand as a batch of products is heated to a certain temperature. They tend not to experience rapid changes in steam pressure and steam flow. Common examples of such processes are: • **Unit Heaters** • **Storage Tank Coils** • **Jacketed Vessels** • **Pipe Coils**

The primary steam trap type for process equipment is a Float & Thermostatic. The **WFT** & **FTT** Series in Cast Iron and Ductile Iron are the most cost-effective solutions to most applications. The **FTE** Series is for higher capacity applications. The **FT600/601** Series traps are available in Cast Steel or Stainless Steel which may be specified for refineries and higher pressure applications. Since rapid pressure changes do not typically occur with batch processes, Thermostatic Bellows traps can also be selected. The **WT2000**, **WT3000** & **WT4000** Series have Stainless Steel bodies and may be preferred for outdoor applications to Cast Iron F&T traps, particularly when a potential for freezing exists.

Continuous Process - Varying Demand • Heating Processes (high to ultra-high capacity)

These applications use steam to heat a continuous flowing product. The modulation of the control valve results in rapid change in steam pressure and flow. Common examples of such processes are:

• **Heat Exchangers** • **Air Handling Coils** • **Instantaneous Water Heaters**

The primary steam trap type for process equipment is a Float & Thermostatic. The **WFT** & **FTT** Series in Cast Iron and Ductile Iron are the most cost-effective solutions to most applications. The **FTE** Series is for higher capacity applications. The **FT600/601** Series traps are available in Cast or Stainless Steel which may be specified for refineries and for higher pressure applications.

Safety Load Factors (SLF's) and appropriate rules to size steam traps

The largest condensate load occurs when the maximum steam pressure is present in the Heat Exchanger (HX). However, if the steam trap is selected based on the maximum condensate load at maximum pressure, it will not be adequately sized at lower differential pressures. This is because the capacity of a steam trap depends on the differential pressure across the trap (less pressure means less capacity) and trap capacity decreases **at a significantly faster rate** than condensate load when the steam pressure drops. When temperature control valves are used to control steam flow to a HX, the pressure may reduce to 0 psig or less. The pressure available to discharge condensate would then be based on head pressure of the drop leg. A drop leg length of 14" will produce a head pressure of ½ psig.

Use the following rules and safety factors for the three categories of process applications. This should assure the trap has adequate capacity at lower differential pressure and not be drastically oversized when operating at full pressure.

- I For applications **NOT** containing a Temperature Control Valve and operate at fairly constant steam pressures; select a steam trap that will handle **2X the maximum condensate load at the maximum differential pressure**.
For Example: if a process will generate 5,000 lbs/hr at 50 psi differential pressure, then choose a trap that can handle 10,000 lbs/hr at 50 psi.
- II For applications **WITH** a Temperature Control Valve and steam pressures **OVER 30 PSI**; select a steam trap that will handle **2.5X the maximum condensate load at the maximum differential pressure**.
For Example: if a process is expected to generate 5,000 lbs/hr at 50 psi differential pressure, then choose a trap that can handle 12,500 lbs/hr at 50 psi.
- III For applications **WITH** a Temperature Control Valve and steam pressures **UNDER 30 PSI**; calculate the maximum condensate load at the maximum differential pressure; select a steam trap that will handle this **maximum amount of condensate at ½ psi differential pressure**. *For Example:* if a process is expected to generate 5,000 lbs/hr at 15 psi differential pressure, then choose a trap that can handle 5,000 lbs/hr at ½ psi differential pressure. The purpose of the ½ psi differential pressure is to allow condensate to properly drain when system pressure goes into vacuum. This assumes the installation of a vacuum breaker and a drop leg of at least 14" in length (for ½ psig) below the HX to give proper condensate head pressure to the steam trap, and trap discharge to atmospheric pressure (0 psig).

PROCESS Applications • Sizing a Trap for Heat Exchanger Application

Goal: Select appropriate model and size steam trap for Process Water Heating application using a Shell & Tube Heat Exchanger in which a maximum of 18 GPM of water is being heated from 45-140°F. Steam Pressure to the control valve is 40 PSI. The trap is discharging to a condensate return line at atmospheric pressure (0 psig back pressure)

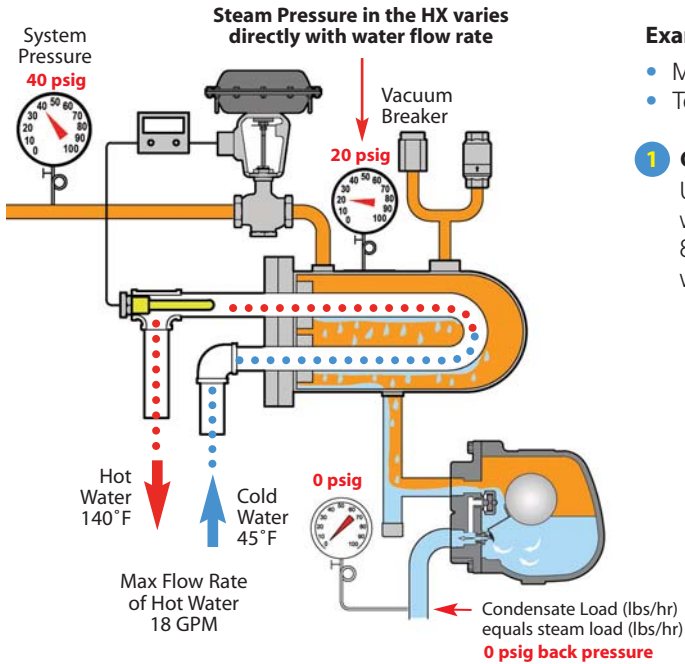

Example: Conditions of Service at Max Load

- Maximum water load to be heated = **18 GPM**
- Temperature Rise: (140°F - 45°F) = **95°F**

1 Calculate Maximum Condensate Load

Using the formula below, to approximate steam load based on water flow rate (GPM) and temperature rise, a Steam Flow of 855 lbs/hr is required; therefore, 855 lbs/hr of condensate will likewise be generated.

$$\text{Steam (lbs/hr)} = \frac{\text{GPM} \times \text{Temp. Rise (}^\circ\text{F)}}{2}$$

$$= \frac{18 \times 95^\circ\text{F}}{2} = 855 \text{ lbs/hr}$$

Steam Flow (lbs/hr) = Condensate Load (lbs/hr)

Condensate (lbs/hr) = 855 lbs/hr

2 Determining the Differential Pressure (ΔP) Across the Trap at the Maximum Condensate Load

In order to size the steam trap, we must first know the pressure in the HX at the Max Condensate Load. This steam pressure is determined by the physical size of the HX. (note that a larger HX uses lower steam pressure while a smaller HX requires a higher steam pressure to heat the same flow of water). If the pressure of the HX is not known, assume 50% of the Pressure at the inlet of the control valve is required in the HX to heat the maximum flow of 18 GPM of water. We therefore have (40 psig x 0.5 = 20 psig) **20 psig steam pressure at 855 lbs/hr.**

3 The Condensate Load at 0 psig Steam Pressure and Conditions at other Water Flow Rates

The steam trap cannot be selected solely based the condensate load at the maximum steam pressure because it will be undersized at lower steam pressures (when there is much less force to push the condensate thru the trap). Lower steam pressures occur when less water is being heated. If the steam pressure and condensate load is known at the lowest pressure, the trap can be selected based on that operating point, and it would be adequately sized at higher pressures. In this particular application, we have a gravity return line at 0 psig back pressure.

Load Chart Based on HX Size to Heat 18 GPM of Water using 20 psig Steam Pressure

	Flow Rate Water (GPM)	Steam Flow (required) (lbs/hr)	Steam Temperature (required) in HX (°F)	Steam Pressure (required) in HX (PSIG)	Actual Pressure in the HX (PSIG)	Trap Differential Pressure (PSI)	Condensate Flow (lbs/hr)
At maximum Flow Rate of 18 GPM	18	855	259	20	20 steam	20	855
Flow Rate of Water at 0 psig Steam Pressure	12.9	614	212	0	0 steam	1/2 psi 14" drip leg	614
At Flow Rate of 10 GPM of Water	10	475	185	-6 vacuum	0 steam & air mixes together	1/2 psi 14" drip leg	475

For this size HX, when water flow rate is 12.9 GPM, the steam temperature required is 212°F, therefore, the steam pressure is 0 psig. At flow rates below 12.9 GPM, the steam pressure would need to go into vacuum or mix with air drawn in thru the vacuum breaker in order to achieve the proper temperature.

Steam Trap Selection Guidelines • PROCESS Applications

4 Using Safety Load Factors to size Steam Traps

The largest condensate load occurs when the maximum steam pressure is present in the HX. However, if the steam trap is selected based on the maximum condensate load at maximum pressure, it will not be adequately sized at lower differential pressures. This occurs because the capacity of a steam trap decreases *at a significantly faster rate* than condensate load when the steam pressure drops. When temperature control valves are used to control steam flow to a HX, the pressure may reduce to 0 psig or less. The pressure available to discharge condensate would then be based on static head pressure of the drip leg. A drip leg length of 14" will produce a static head pressure of 1/2 psig.

In this application, 614 lbs/hr of condensate is being generated at 0 psig steam pressure. See Load Chart. The appropriate safety load factor for this application is 2.5X the maximum condensate load of 855 lbs/hr. Therefore, select a steam trap based on: $2.5 \times 855 = 2,138 \text{ lbs/hr}$ at a differential pressure of 20 psi.

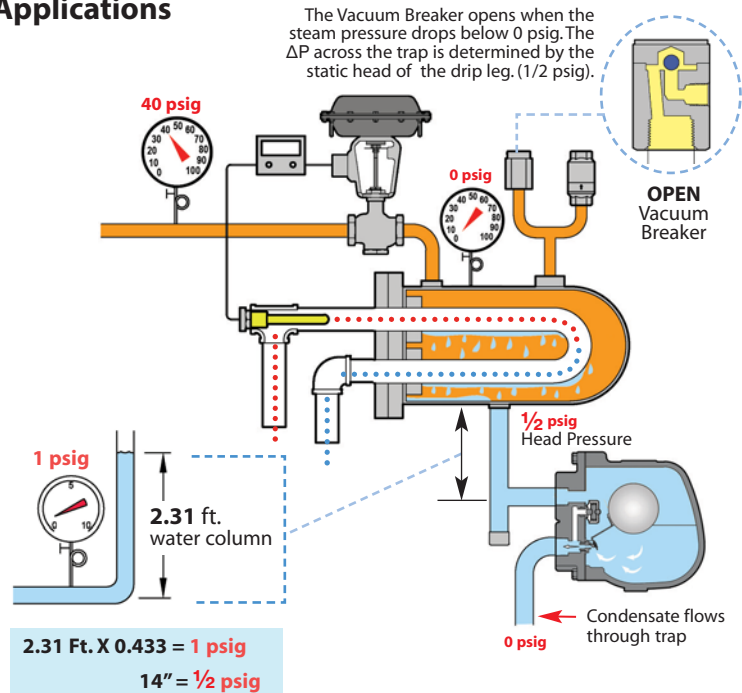

5 Selecting the Steam Trap

The steam trap should be sized for a condensate load of $2.5 \times 855 = 2,138 \text{ lbs/hr}$ at 20 psi differential pressure. The HX is assumed to have 20 psig steam pressure at the maximum water usage of 18 GPM. However, when selecting the PMO (maximum operating pressure) for the trap, assume the actual pressure could reach nearly the full line pressure of 40 psig. Therefore, select a trap with a PMO of at least 40 psig.

Referring to the WFT Capacity chart below, we must select a **WFT-075** model with a PMO of 75 psig. Enter the 20 psi column inside the **WFT-075** section and scroll down until a condensate load greater than 2,138 lbs/hr is found. The capacity of 3,850 lbs/hr is the first condensate load greater than 2,138 lbs/hr.

For this application, the **WFT-075-15-N** will be capable of discharging the calculated condensate loads of 2,138 lbs/hr at 20 psi ΔP and 614 lbs/hr at 1/2 psi ΔP.

CAPACITIES		Condensate (lbs/hr)													
Model Code	PMO (PSIG)	Pipe Size	Orifice Size	Differential Pressure (PSI)											
				1/4	1/2	1	2	5	10	15	20	30	40	50	75
WFT-015-13-N	15	3/4"	0.250	390	490	620	780	1050	1320	1500					
WFT-015-14-N	15	1"	0.250	390	490	620	780	1050	1320	1500					
WFT-015-15-N	15	1 1/4"	0.312	610	770	960	1210	1630	2040	2330					
WFT-015-16-N	15	1 1/2"	0.500	1420	1910	2570	3460	5120	6890	8190					
WFT-015-17-N	15	2"	0.625	2260	2950	3860	5040	7170	9360	10930					
WFT-030-13-N	30	3/4"	0.228	330	420	530	670	930	1180	1350	1500	1720			
WFT-030-14-N	30	1"	0.228	330	420	530	670	930	1180	1350	1500	1720			
WFT-030-15-N	30	1 1/4"	0.228	330	420	530	670	930	1180	1350	1500	1720			
WFT-030-16-N	30	1 1/2"	0.390	930	1240	1650	2190	3210	4280	5060	5700	6750			
WFT-030-17-N	30	2"	0.500	1420	1910	2570	3460	5120	6890	8190	9360	11020			
WFT-075-13-N	75	3/4"	0.166	175	225	295	385	545	705	825	920	1075	1200	1305	1525
WFT-075-14-N	75	1"	0.166	175	225	295	385	545	705	825	920	1075	1200	1305	1525
WFT-075-15-N	75	1 1/4"	0.312	640	850	1130	1500	2180	2900	3420	3850	4540	5110	5600	6610
WFT-075-16-N	75	1 1/2"	0.312	640	850	1130	1500	2180	2900	3420	3850	4540	5110	5600	6610
WFT-075-17-N	75	2"	0.422	1020	1340	1760	2310	3330	4380	5140	5760	6770	7590	8290	9730

Up to 15 PSI

Up to 30 PSI

Up to 75 PSI

1 1/4" trap is able to handle the condensate load of 614 lbs/hr at 1/2 psi. (see Load Chart to left)

This 3/4" trap can discharge 855 lbs/hr at 20 psi but is drastically undersized at 1/2 psi

The actual load is only 855 lbs/hr. However, with 2.5X SLFs applied, this larger trap was selected since it has adequate capacity at lower pressures.

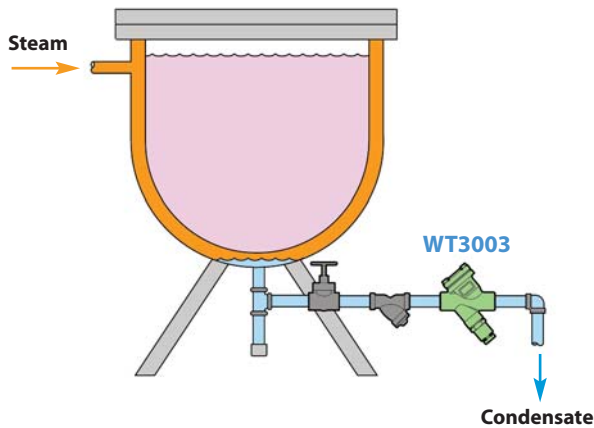

Jacketed Kettle

As the name implies, Jacketed Kettles have a Jacket of Steam surrounding the outside of a Kettle. They are commonly used in the food and beverage industry for indirect heating of the contents in the kettle. This application demonstrates the use of the WT3003 Thermostatic Steam trap. Along with high condensate capacity handling and superior air handling capability, this trap can also operate at higher pressures. An advantage they have over F&T traps is that a single trap model operates over the entire pressure range making them easier to apply and maintain. It is typically recommended to install a thermostatic trap approximately 2 feet from process outlet piping to accommodate some back-up of condensate due to sub-cooling.

Rotating Steam Dryer

Commonly found in the Paper Making industry, a rotating piece of equipment offers a unique challenge of removing the condensate. Steam inside a rotating drum cylinder is used to heat product such as sheets of paper over the outside surface of the drum. Since the drum is rotating, the trap must be positioned **above** the condensate collection point. The steam pressure inside the drum pushes the condensate up through the pipe to the steam trap. If steam enters the tubing, it will "Steam Lock" the trap by causing it to close which in turn causes the condensate to build up inside the rotating drum. Since the pipe line is surrounded by steam, it may take an extended length of time for the steam in the pipe to dissipate. By using the Steam Lock Release feature, a small amount of steam is continually discharged thru the seat, allowing the condensate to continually reach the steam trap. This steam lock release feature is available on ALL F&T and Thermostatic traps and should be considered on this type of application.

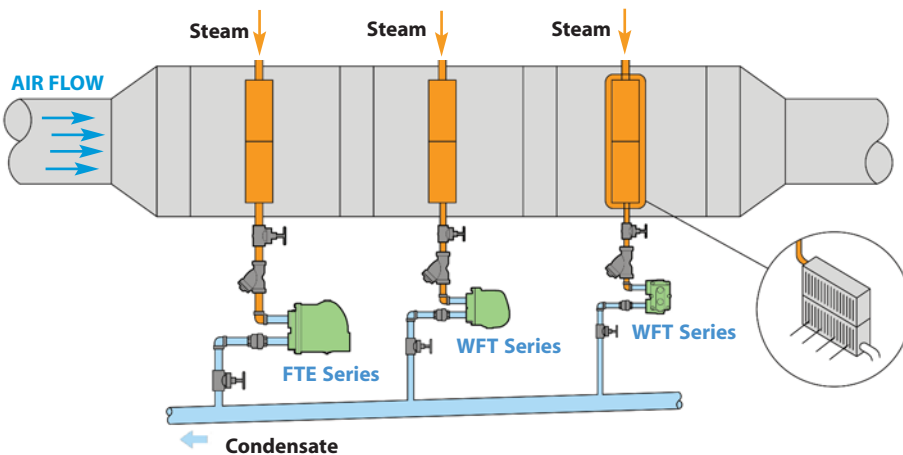
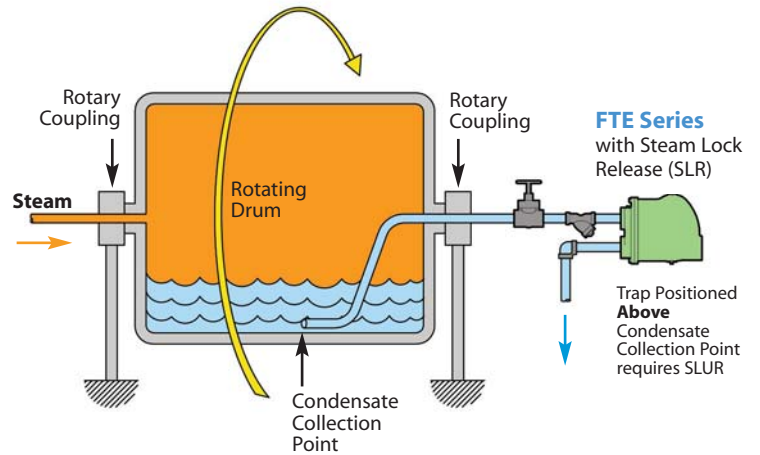

Multi-Bank Air Heating Coils / Air Handling Unit (AHU)

For certain Industrial Heating and Drying applications, several Air Heating coils of various sizes may be set up in series to accommodate the process. The heat load of each coil should be taken into account when sizing the steam traps. It's preferable to have a separate steam trap on each individual coil.

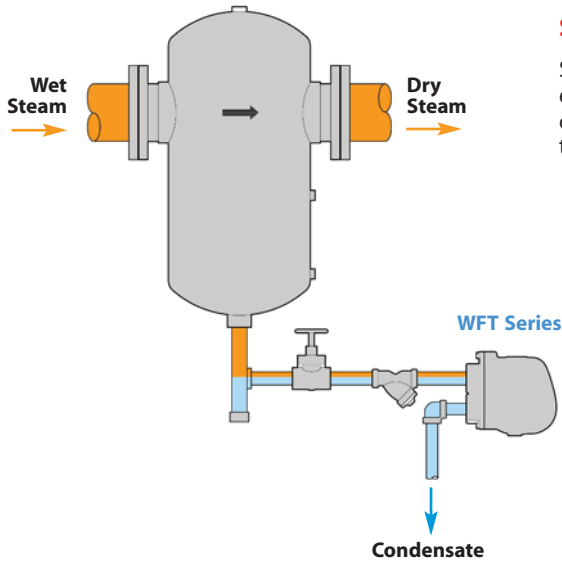

Steam Separator

Separators are used on steam mains and steam supply lines to remove entrained water in the steam. Steam flows through the Separator and the condensate falls by gravity to the bottom where it needs to be discharged through a steam trap. F&T traps are recommended for this application.

Storage Tank Coil

When heating Storage tanks, the heat exchanger may be placed inside the tank. This may be simpler and less expensive than using a pump to circulate the product thru an external heat exchanger. Shown is a WT4000 Series thermostatic process trap removing the condensate. If a small amount of sub-cooled condensate is backed up, it will not adversely affect the process.

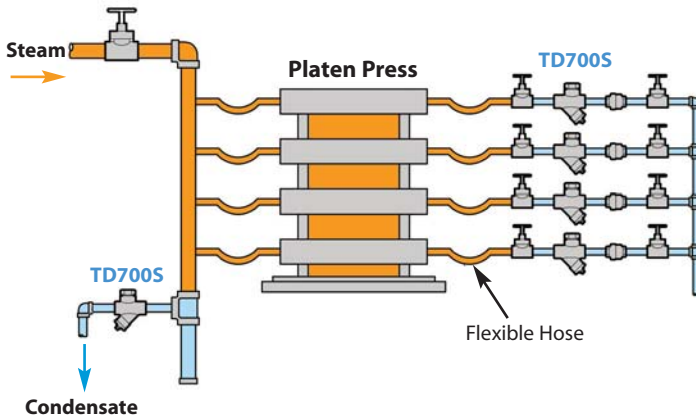
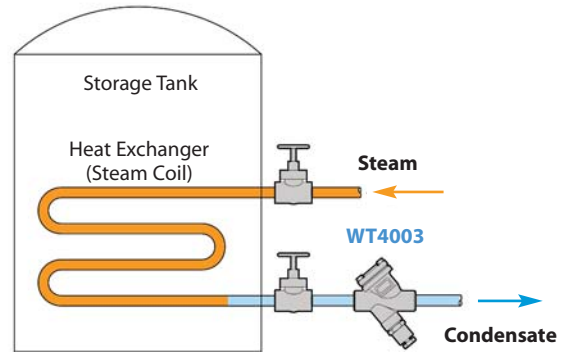





Platens

Platens are extensively used in the molding industry when steam is required to heat the mold, allowing plastics and rubber to be formed into different shapes and sizes. On this particular Process application, a TD700S thermodynamic trap is being used to remove the condensate. Since Air is generally only present during system start-up, and this type of process may run non-stop for extended periods of time, a thermodynamic trap is a potential choice for this application.

Thermodynamic

Model	Body Material	PMO (PSIG)	Sizes	Connections	Page No.
TD600	Stainless Steel	600	3/8" – 1"	NPT	38
TD600S	Stainless Steel	600	1/2", 3/4", 1"	NPT	40
TD700S	Alloy Steel	600	1/2", 3/4", 1"	NPT, SW, FLG	42
TD900S	Alloy Steel	900	1/2", 3/4", 1"	NPT, SW, FLG	44
TD3600	Alloy Steel	3600	1/2", 3/4", 1"	SW, BW, FLG	46

		Characteristics	Material	Application
TD600	 No Strainer	The one piece body-seat design is extremely simple, rugged and economical, however, they are not fully in-line repairable. Trap body cannot be welded in-line.	420 Stainless Steel	Most widely used and economical thermodynamic trap for Drip & Tracing Applications 30 to 600 psig
	 Strainer			
TD700S	 Replacement Capsule Feature	In-line Repairable Seat & body are non-integral. Replacement capsule allows for complete repair without removing trap body from piping system. Can be welded in-line.	Alloy Steel	Drip & Tracing Applications 30 to 600 psig
TD900S		In-line Repairable Seat & body are non-integral; allows for complete repair without removing trap body from piping system. Can be welded in-line.	Alloy Steel	Drip Application High-Pressure to 900 psig
TD3600		Ultra High-Pressure 3600 PSIG In-line Repairable Can be welded in-line.	Alloy Steel	Drip Application Ultra High-Pressure to 3600 psig

Introduction

THERMODYNAMIC TRAPS

Thermodynamic traps use only one moving part, the valve disc, which allows condensate to be discharged when present and closes tightly upon the arrival of steam. These traps have an inherently rugged design and are commonly used as drip traps on steam mains and supply lines. Their solid construction and single moving part make them resistant to waterhammer and are freeze-proof when installed vertically. Thermodynamic traps will only discharge small amounts of air and therefore are typically not used in process applications. Since Thermodynamic traps rely on steam velocity to operate, they are not intended for low pressure service (below 30 PSI).

Operation:

The inlet pressure to the trap pushes the disc off the seat and allows unwanted condensate to be discharged through the peripheral outlet surrounding the inlet (**Figure A**). As hot condensate reaches the disc chamber, flash steam is created that travels at high velocity from the inlet to the outlet creating a low pressure area under the disc and higher pressure above the disc (**Figure B**). This differential pressure causes the disc to close against the seat and trap the steam in the system (**Figure C**). The steam pressure above the disc creates a force holding the disc closed. Heat transfer takes place through the cap and the steam pressure above the disc begins to reduce. When the downward force created by the steam pressure above the disc falls below the force created by the incoming condensate, the disc is pushed off its seat and the process repeats itself (**Figure A**). Cycle time is dependent on steam temperature, and more importantly, ambient temperature outside the trap. Since the amount of time the valve remains closed is primarily dependent on the heat transfer from the steam above the disc to the ambient environment, frequent cycling of the valve can occur in cold or wet environments. Applying an insulating cap over the cover of the trap will reduce the cycle rate.

A) Valve Disc (Open)

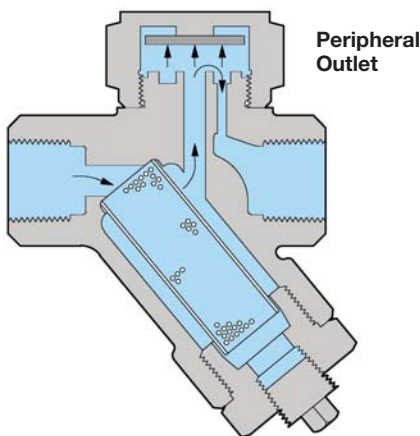

B) Valve Disc (Starting to Close)

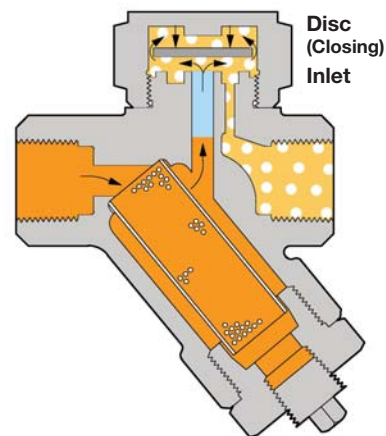

C) Valve Disc (Closed)

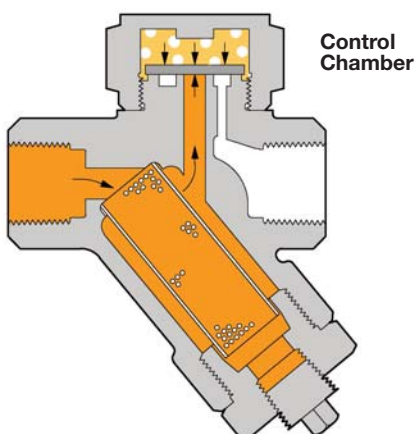

- A)** When condensate is present, trap remains in the open position allowing condensate to discharge.
- B)** When steam enters the trap, it creates an internal pressure above the disc that instantly forces the disc and seat to close tightly, preventing steam from escaping.
- C)** Trap will remain closed, trapping steam in the system until the steam above the disc condenses, due to heat loss through the cap.

Model	TD600, TD600L
Sizes	3/8", 1/2", 3/4", 1"
Connections	NPT
Body Material	Stainless Steel 420F
Options	Insulation Cap
PMO Max. Operating Pressure	600 PSIG
TMO Max. Operating Temperature	800°F
PMA Max. Allowable Pressure	600 PSIG up to 800°F
TMA Max. Allowable Temperature	800°F @ 600 PSIG



Typical Applications

DRIP, TRACING: TD600 model steam traps are most commonly used in drip applications, such as draining condensate from steam mains and steam supply lines. They can also be used for steam tracing applications. These traps are suitable for outdoor applications that are subject to freezing as well as superheated steam conditions. They are compact and rugged with only a single moving part. If a trap with an integral strainer is desired, the TD600S is recommended. If a fully in-line repairable design is required, the TD700S or the UTD450 with Universal Quick-Change connector is recommended.

How It Works

The disc is the only moving part inside a thermodynamic trap. When steam enters the trap, it creates an internal pressure above the disc that instantly forces the disc to close tightly on the seat, preventing the steam from escaping. The internal steam pressure (holding the disc and seat shut) eventually drops, and the trap re-opens. When condensate enters the trap, it pushes the disc upwards, allowing the condensate to freely discharge. If steam is present, the trap instantly shuts.

Features

- High pressure applications up to 600 PSIG
- Hardened stainless steel seat and disc for extended service life even at high pressure
- Single trap will operate over the entire pressure range of 3.5-600 PSIG (recommended above 30 PSIG)
- Suitable for superheated steam
- Freeze-proof when trap is piped in a vertical orientation for complete drainage of condensate
- Three-hole balanced discharge extends life of the seat area
- Trap will function in any orientation (horizontal preferred)

Sample Specification

The steam trap shall be a thermodynamic disc type with all stainless steel construction. Integral seat design and disc to be hardened for long service life. Unit shall be capable of installation in any orientation and self-draining when mounted vertically.

Installation and Maintenance

The TD600 can be installed in any orientation; however, horizontal with cap facing upward is preferred for longest service life. The one piece body-seat design is extremely simple and economical; however, this configuration is generally considered not fully repairable since the seat cannot be repaired if damaged or worn. Welding of trap body directly into pipeline is not recommended since excessive heat may cause distortion of the seat area. The TD600 does not contain an integral strainer and separate strainer should therefore be installed to protect from dirt and pipe scale. If a fully in-line repairable design or a trap that can be welded into pipeline is desired, the TD700S, TD900S or the UTD450 with Universal Quick-Change connector is recommended.

Helpful Selection Information

The TD600L has reduced size discharge orifice holes which are preferable in terms of performance, longevity, and efficiency; particularly on pressures over 150 psi. For most drip applications the 1/2" TD600L should have sufficient capacity. For higher load drip applications or if a 3/4" pipe connection is required, use 3/4" TD600L for best results. Choosing a model with a condensate handling capacity in the range of the specific application will prolong trap life.

L = Reduced Size Discharge Orifice holes which are preferable in terms of performance, longevity, and efficiency; particularly on pressures over 150 psi.

Options

An insulation cap is available to reduce cycle rates and steam loss in rain, snow, or cold environments.

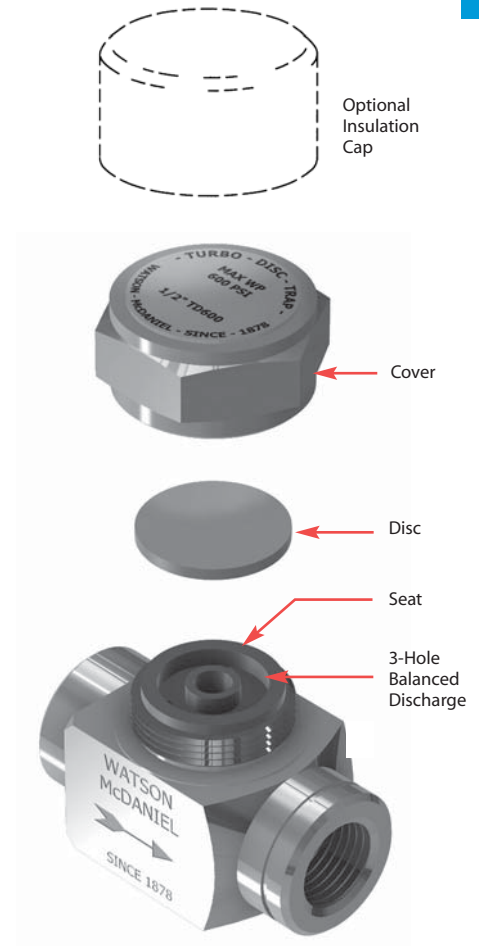
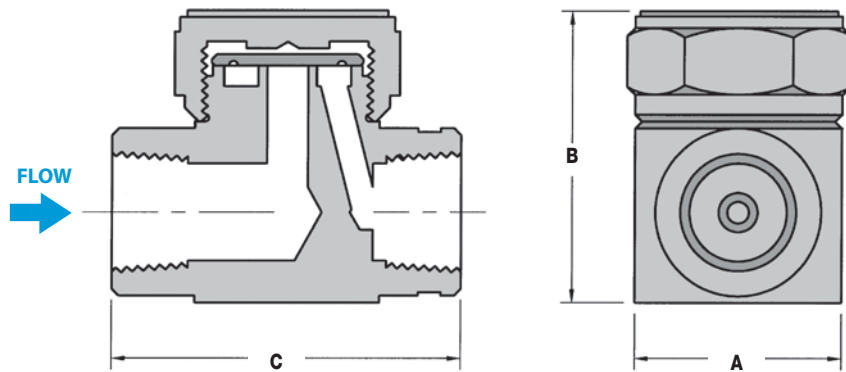

DIMENSIONS & WEIGHTS – inches						
Size	Model Code	Connection	A	B	C	Weight (lbs)
3/8"	TD600-11-N	NPT	1.37	1.69	2.00	0.75
1/2"	TD600-12-N	NPT	1.50	2.00	2.69	1.25
3/4"	TD600-13-N	NPT	1.75	2.38	2.81	2.00
1"	TD600-14-N	NPT	2.12	2.81	3.81	3.00
1/2"	TD600L-12-N	NPT	1.50	1.81	2.71	1.00
3/4"	TD600L-13-N	NPT	1.50	2.25	2.75	1.75

How to Size / Order

Select working pressure; follow column down to correct capacity (lbs/hr) block. Example:

Application: 500 lbs/hr at 100 PSIG working inlet pressure

Size/Model: 3/4" **TD600L-13-N**

MATERIALS

Body	Stainless Steel, AISI 420F
Disc	Stainless Steel, AISI 420
Cover	Stainless Steel, AISI 416
Insulation Cap	Stainless Steel, AISI 304

CAPACITIES – Condensate (lbs/hr)

Size	Model Code	Steam Inlet Pressure (PSIG)																				
		3.5	5	10	15	20	25	30	40	50	75	100	150	200	250	300	350	400	450	500	550	600
1/2"	TD600L-12-N	180	185	190	195	200	215	220	230	250	310	375	500	620	710	800	825	900	1070	1120	1185	1290
3/4"	TD600L-13-N	300	315	350	380	415	440	470	515	580	710	825	1020	1165	1300	1440	1565	1670	1775	1880	1960	2060
3/8"	TD600-11-N	180	185	190	195	200	215	220	230	250	310	375	500	620	710	800	825	900	1070	1120	1185	1290
1/2"	TD600-12-N	300	315	350	380	415	440	470	515	580	710	825	1020	1165	1300	1440	1565	1670	1775	1880	1960	2060
3/4"	TD600-13-N	415	430	475	520	565	610	650	720	825	1020	1185	1480	1710	1950	2110	2265	2490	2625	2780	2985	3140
1"	TD600-14-N	650	680	740	815	885	940	1000	1080	1225	1500	1800	2215	2625	2935	3300	3600	3875	4120	4350	4560	4840

Notes: 1) Maximum back pressure not to exceed 80% of inlet pressure (measured in absolute pressure) or trap may not close.
 2) For optimum performance, recommended for operating pressure above 30 PSIG.

Steam Traps

Thermodynamic Steam Trap

TD600S

Thermodynamic

Model	TD600S, TD600LS
Sizes	1/2", 3/4", 1"
Connections	NPT
Body Material	Stainless Steel 420F
Options	Blowdown Valve, Insulation Cap
PMO Max. Operating Pressure	600 PSIG
TMO Max. Operating Temperature	750°F
PMA Max. Allowable Pressure	915 PSIG up to 250°F
TMA Max. Allowable Temperature	610°F @ 750 PSIG



TD600S
Strainer



TD600SB
Strainer &
Blowdown Valve

Typical Applications

DRIP, TRACING: TD600S model steam traps with integral strainer are most commonly used in drip applications, such as draining condensate from steam mains and steam supply lines. They can also be used for steam tracing applications. These traps are suitable for outdoor applications that are subject to freezing as well as superheated steam conditions. They are compact and rugged with only a single moving part. Integral strainer protects against dirt and scale. If a fully in-line repairable design is required, the TD700S or the UTD450 with Universal Quick-Change Connector is recommended.

How It Works

The disc is the only moving part inside a thermodynamic trap. When steam enters the trap, it creates an internal pressure above the disc that instantly forces the disc to close tightly on the seat, preventing the steam from escaping. The internal steam pressure (holding the disc and seat shut) eventually drops, and the trap re-opens. When condensate enters the trap, it pushes the disc upwards, allowing the condensate to freely discharge. If steam is present, the trap instantly shuts.

Features

- Integral strainer with optional blowdown valve to protect trap from contamination
- High pressure applications up to 600 PSIG
- Hardened stainless steel seat and disc for extended service life even at high pressure
- Single trap will operate over the entire pressure range of 3.5-600 PSIG (recommended above 30 PSIG)
- Suitable for superheated steam
- Freeze-proof when trap is piped in a vertical orientation for complete drainage of condensate
- Three-hole balanced discharge extends life of the seat area
- Trap will function in any orientation (horizontal preferred)

Sample Specification

The steam trap shall be all stainless steel thermodynamic type with hardened integral seat and disc with integral strainer and blowdown valve.

Installation and Maintenance

The TD600S can be installed in any orientation; however, horizontal with cap facing upward is preferred for longest service life. The one piece body-seat design is extremely simple and economical; however, this configuration is generally considered not fully repairable since the seat cannot be replaced if damaged or worn. Welding of trap body directly into pipeline is not recommended since excessive heat can cause distortion of the seat area. All models of the TD600S contain an integral strainer for protection against dirt and scale. If a fully in-line repairable design or a trap that can be welded into pipeline is desired, the TD700S, TD900S or the UTD450 with Universal Quick-Change connectors is recommended.

Helpful Selection Information

The TD600LS has reduced size discharge orifice holes which are preferable in terms of performance, longevity, and efficiency; particularly on pressures over 150 psi. For most drip applications the 1/2" TD600LS should have sufficient capacity. For higher load drip applications or if a 3/4" pipe connection is required, use 3/4" TD600LS for best results. Choosing a model with a condensate handling capacity in the range of the specific application will prolong trap life.

L = Reduced Size Discharge Orifice holes which are preferable in terms of performance, longevity, and efficiency; particularly on pressures over 150 psi.

Options

An insulation cap is available to reduce cycle rates and steam loss in rain, snow, or cold environments. Blowdown valve, used for flushing dirt and scale from strainer.

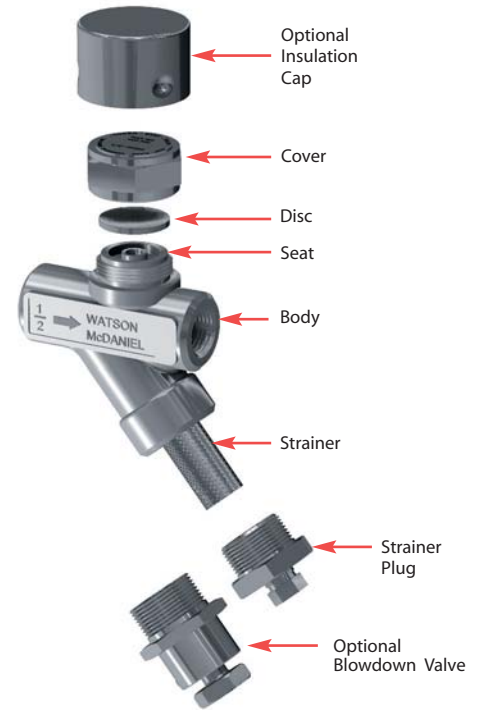
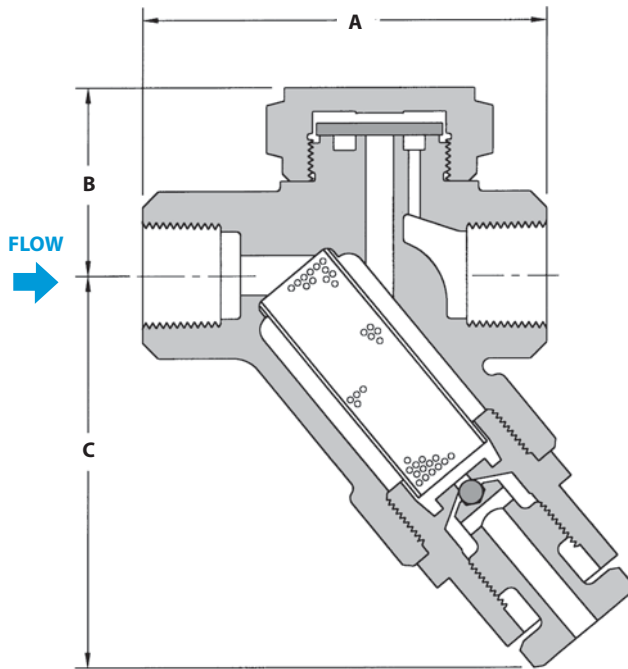

DIMENSIONS & WEIGHTS – inches						
Size	Model	Conn.	A	B	C	Weight (lbs)
Series TD600S (Strainer)						
1/2"	TD600S-12-N	NPT	3.16	1.50	2.53	2
1/2"	TD600LS-12-N	NPT	3.16	1.44	2.53	1.5
3/4"	TD600S-13-N	NPT	3.56	1.62	2.53	2.5
3/4"	TD600LS-13-N	NPT	3.56	1.56	2.53	2.4
1"	TD600LS-13-N	NPT	3.75	1.44	2.53	2.5
Series TD600SB (Strainer & Blowdown Valve)						
1/2"	TD600SB-12-N	NPT	3.16	1.50	3.5	2.3
1/2"	TD600LSB-12-N	NPT	3.16	1.44	3.5	2.0
3/4"	TD600SB-13-N	NPT	3.56	1.62	3.5	2.8
3/4"	TD600LSB-13-N	NPT	3.56	1.56	3.5	2.7
1"	TD600LSB-14-N	NPT	3.72	1.44	3.5	2.7

MATERIALS	
Body	Stainless Steel, AISI 420F
Disc	Stainless Steel, AISI 420
Cover	Stainless Steel, AISI 416
Insulation Cap	Stainless Steel, AISI 304
Strainer Screen	Stainless Steel, AISI 304
Blowdown Valve	Stainless Steel, AISI 303

How to Size / Order
 Select working pressure; follow column down to correct capacity (lbs/hr) block. Example:
 Application: 500 lbs/hr at 100 PSIG working inlet pressure
 Size/Model: 3/4" **TD600LS-13-N**

CAPACITIES – Condensate (lbs/hr)		Steam Inlet Pressure (PSIG)																			
Size	Model	3.5	5	10	15	20	25	30	40	50	75	100	150	200	250	300	400	450	500	550	600
1/2"	TD600LS-12-N	180	185	190	195	200	215	220	230	250	310	375	500	620	710	800	900	1070	1120	1185	1290
1"	TD600LS-14-N																				
3/4"	TD600LS-13-N	300	315	350	380	415	440	470	515	580	710	825	1020	1165	1300	1440	1670	1775	1880	1960	2060
1/2"	TD600S-12-N	300	315	350	380	415	440	470	515	580	710	825	1020	1165	1300	1440	1670	1775	1880	1960	2060
3/4"	TD600S-13-N	415	430	475	520	565	610	650	720	825	1020	1185	1480	1710	1950	2110	2265	2625	2780	2985	3140

Note: Maximum back pressure not to exceed 80% of inlet pressure (measured in absolute pressure) or trap may not close.
Note: For optimum performance, recommended for operating pressure above 30 PSIG.

Steam Traps

Thermodynamic Steam Trap (Repairable)

TD700S

Thermodynamic

Model	TD700S, TD700HS
Sizes	1/2", 3/4", 1"
Connections	NPT, SW, FLG
Body Material	Chrome-Moly Alloy Steel
Options	Blowdown Valve, Insulation Cap
PMO Max. Operating Pressure	600 PSIG
TMO Max. Operating Temperature	800°F
PMA Max. Allowable Pressure	600 PSIG up to 800°F
TMA Max. Allowable Temperature	800°F @ 600 PSIG

TD700S is a Direct Replacement for Yarway Model 721



TD700S
Strainer



TD700SB
Strainer &
Blowdown Valve

Typical Applications

DRIP, TRACING: TD700S model steam traps are fully in-line repairable and most commonly used in drip applications, such as draining condensate from steam mains and steam supply lines. They can also be used for steam tracing applications. These traps are suitable for outdoor applications that are subject to freezing as well as superheated steam conditions. They feature a "Quick-Replace" capsule that contains the trap's complete internal working mechanism, which is easily replaced while the trap body remains in-line. All models contain an integral strainer for protection against dirt and scale.

How It Works

The disc is the only moving part inside a thermodynamic trap. When steam enters the trap, it creates an internal pressure above the disc that instantly forces the disc to close tightly on the seat, preventing the steam from escaping. The internal steam pressure (holding the disc and seat shut) eventually drops, and the trap re-opens. When condensate enters the trap, it pushes the disc upwards, allowing the condensate to freely discharge. If steam is present, the trap instantly shuts.

Features

- "Quick-Replace" capsule design for easy in-line repair
- Integral strainer with optional blowdown valve to protect trap from contamination
- High pressure applications up to 600 PSIG
- Hardened stainless steel seat and disc for extended service life even at high pressure
- Single trap will operate over the entire pressure range 4-600 PSIG (recommended above 30 PSI)
- Suitable for superheated steam
- Freeze-proof when trap is piped in a vertical orientation for complete drainage of condensate
- Non-integral seat and chrome-moly body allow for trap to be welded in-line
- Trap will function in any orientation (horizontal preferred)

Sample Specification

The steam trap shall be a thermodynamic style in a chrome-moly alloy steel body with an integral strainer and optional blowdown valve. Unit shall have an all stainless steel in-line removable seat and disc capsule assembly. Trap shall be capable of installation in any orientation and self-draining when mounted vertically.

Installation and Maintenance

The TD700S can be installed in any orientation; however, horizontal with cap facing upward is preferred for longest service life. For maintenance, ALL internal components are easily removed and completely changed using a replacement kit. All models of the TD700S contain an integral strainer for protection against dirt and scale. Available in NPT, Socket-Weld and Flange connections.

Helpful Selection Information

The TD700HS is a high pressure version of the standard TD700S model. While both the TD700S and TD700HS will operate with pressures up to 600 PSIG, the TD700HS has a slightly smaller discharge orifice and is recommended for system pressures over 300 PSIG because of increased efficiency and performance. The TD700S is available in NPT, socket weld, and flange connections from 1/2" through 1". Replacement capsules are available, see Parts & Kits Section.

Options

Blowdown valve, used for flushing dirt and scale from strainer.
Customized Flanged Connections:

TD700HS

The **TD700HS** is the high pressure version of the TD700S.

The standard model **TD700S** will operate over the entire pressure range, however, the **TD700HS** will operate more efficiently and have a longer service life for pressures over 300 PSIG.

TD700S Standard pressure capsule 4-300 PSIG

TD700HS High pressure capsule 150-600 PSIG

Option: **TD700SB** = Blowdown Valve

Steam Traps

Thermodynamic Steam Trap (Repairable)

TD700S

Thermodynamic

STEAM TRAPS

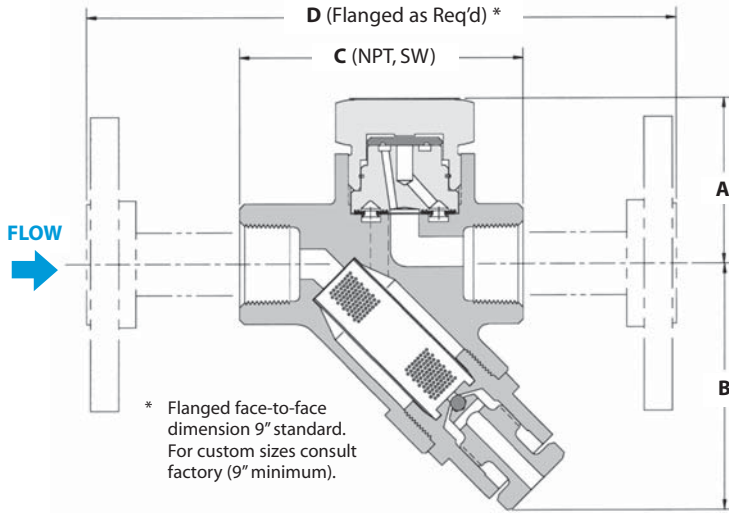

* Flanged face-to-face dimension 9" standard. For custom sizes consult factory (9" minimum).

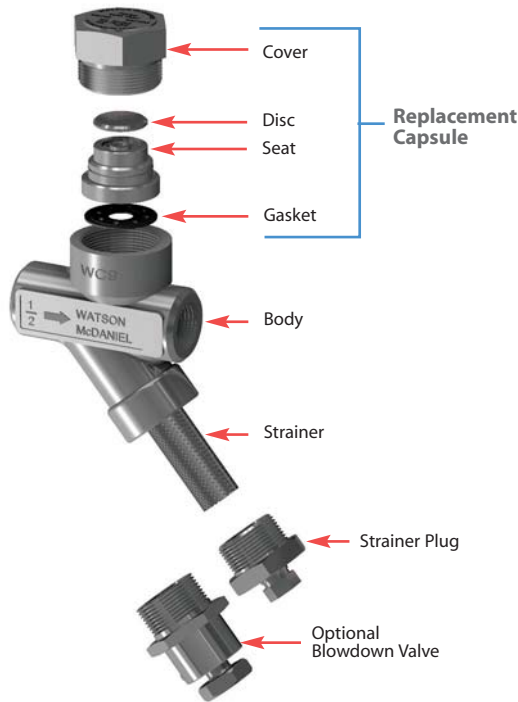

DIMENSIONS & WEIGHTS – inches

Size/Model	Connection	A	B	C	Weight (lbs)
Series TD700S & TD700HS (Strainer)					
1/2"	NPT, SW	2.04	2.50	3.16	2.0
3/4"	NPT, SW	2.04	2.50	3.55	2.0
1"	NPT, SW	2.04	2.50	6.31	2.0
Series TD700SB & TD700HSB (Strainer & Blowdown Valve)					
1/2"	NPT, SW	2.04	3.06	3.16	2.25
3/4"	NPT, SW	2.04	3.06	3.55	2.25
1"	NPT, SW	2.04	3.06	6.31	2.25

MATERIALS

Body	Chrome Moly ASTM A-217, GR WC9
Seat	Stainless Steel, 420F
Seat Gasket	316SS/Grafoil
Cover	Stainless Steel, 416
Disc	Stainless Steel, 420
Retaining Ring	Stainless Steel Spring Wire
Screen	Stainless Steel, 304
Strainer Plug, Pipe Plug	Stainless Steel, 303
Blowdown Valve	Stainless Steel
Flanges	Carbon Steel

How to Size / Order

Select working pressure; follow column down to correct capacity (lbs/hr) block. Example:

Application: 275 lbs/hr at 100 PSIG working inlet pressure
 Size/Model: **TD700S**, specify pipe size and connections (NPT, SW, FLG)

CAPACITIES – Condensate (lbs/hr)

Size	Conn.	Model Code	Steam Inlet Pressure (PSIG)																		
			4	5	6	7	8	9	10	20	30	40	50	60	80	100	150	300	400	500	600
1/2"	NPT	TD700S-12-N	95	105	115	120	125	130	140	180	220	250	265	280	320	350	405	550	600	650	700
	SW	TD700S-12-SW																			
3/4"	NPT	TD700S-13-N	95	105	115	120	125	130	140	180	220	250	265	280	320	350	405	550	600	650	700
	SW	TD700S-13-SW																			
1"	NPT	TD700S-14-N	95	105	115	120	125	130	140	180	220	250	265	280	320	350	405	550	600	650	700
	SW	TD700S-14-SW																			
1/2"	NPT	TD700HS-12-N															250	330	380	410	450
	SW	TD700HS-12-SW																			
3/4"	NPT	TD700HS-13-N															250	330	380	410	450
	SW	TD700HS-13-SW																			
1"	NPT	TD700HS-14-N															250	330	380	410	450
	SW	TD700HS-14-SW																			

Notes: 1) Maximum back pressure not to exceed 80% of inlet pressure (measured in absolute pressure) or trap may not close.
 2) For optimum performance, recommended for operating pressure above 30 PSIG.

Model	TD900S, TD900LS
Sizes	1/2", 3/4", 1"
Connections	NPT, SW, 600# FLG
Body Material	Low Carbon Chrome-Moly
Options	Insulation Cap
PMO Max. Operating Pressure	900 PSIG
TMO Max. Operating Temperature	842°F
PMA Max. Allowable Pressure	1500 PSIG @ 100°F
TMA Max. Allowable Temperature	842°F @ 981 PSIG



Typical Applications

DRIP: TD900S model steam traps, capable of handling pressures up to 900 PSIG, are used in drip applications such as draining condensate from steam mains and steam supply lines. The complete internal working mechanism can be replaced while the trap body remains connected in-line. All models contain an integral strainer for protection against dirt and scale. These traps are suitable for outdoor applications that are subject to freezing as well as superheated steam conditions.

How It Works

The disc is the only moving part inside a thermodynamic trap. When steam enters the trap, it creates an internal pressure above the disc that instantly forces the disc to close tightly on the seat, preventing the steam from escaping. The internal steam pressure (holding the disc and seat shut) eventually drops, and the trap re-opens. When condensate enters the trap, it pushes the disc upwards, allowing the condensate to freely discharge. If steam is present, the trap instantly shuts.

Features

- "Quick-Change" seat and disc for easy in-line repair
- High pressure applications up to 900 PSIG
- Integral strainer to protect trap from contamination
- Hardened stainless steel seat and disc for extended service life even at extremely high pressures
- Single trap model will operate over the entire pressure range (20-900 PSIG)
- Suitable for superheated steam
- Freeze-proof when trap is piped in a vertical orientation for complete drainage of condensate
- Trap will function in any orientation (horizontal preferred)

Sample Specification

The steam trap shall be a thermodynamic style with body material in chrome-moly alloy steel. Available in size 1/2", 3/4" and 1" Class 600 socket weld ends or flanges. Unit shall have hardened stainless steel seat and disc with a removable stainless steel strainer.

Installation and Maintenance

The TD900S can be installed in any orientation; however, horizontal with cap facing upward is preferred for longest service life. For maintenance, ALL internal components are easily removed and completely changed using a replacement kit. All models contain an integral strainer for protection against dirt and scale. Available in NPT, Socket-Weld and Flange connections.

Helpful Selection Information

The TD900LS is a reduced capacity version of the standard TD900S model. The TD900S is available in NPT, Socket Weld, and Flange connections from 1/2" thru 1".

Options

Customized Flanged Connections: Specify size and face-to-face dimensions.

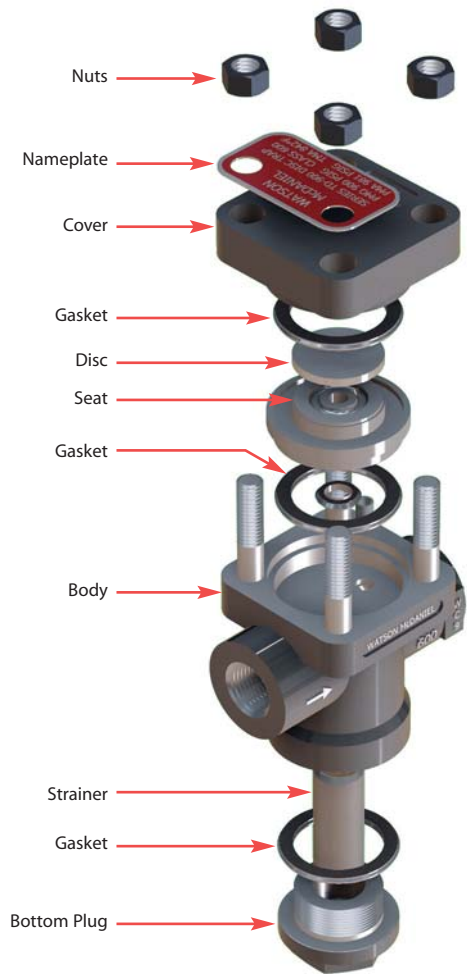

Complete internal working mechanism can be replaced while trap body remains connected in-line

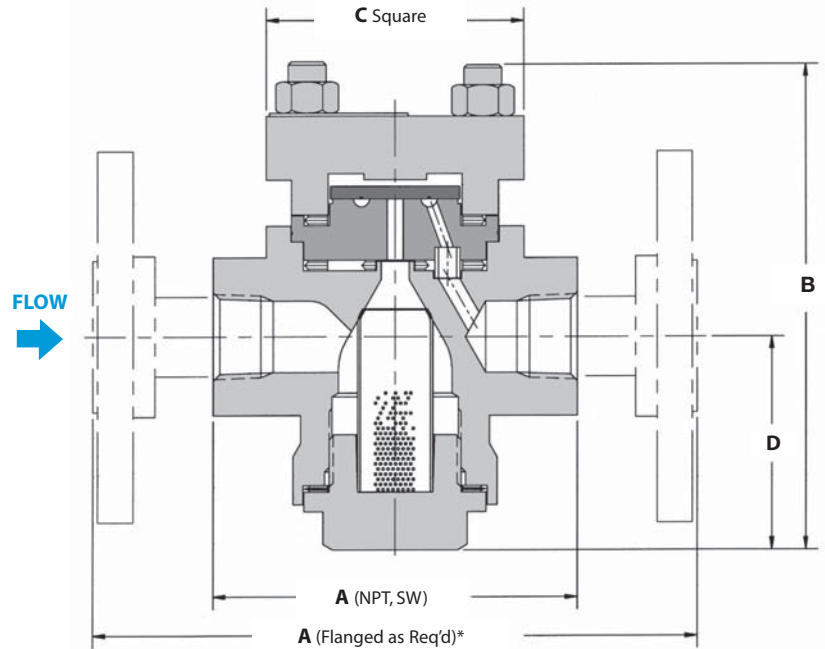

* Flanged face-to-face dimension 9" standard. For custom sizes consult factory (9" minimum).

DIMENSIONS & WEIGHTS – inches

Size	Model	Connection	A	B	C	D	Weight (lbs)
1/2"	TD900S/TD900LS	NPT, SW	3.6	4.8	2.6	2.1	4.5
		*600# FLG	9.0	4.8	2.6	2.1	9.0
3/4"	TD900S/TD900LS	NPT, SW	3.6	4.8	2.6	2.1	4.5
		*600# FLG	9.0	4.8	2.6	2.1	11.0
1"	TD900S/TD900LS	NPT, SW	6.5	4.8	2.6	2.1	4.5
		*600# FLG	9.0	4.8	2.6	2.1	11.0

MATERIALS

Body	Alloy Steel, GR WC9
Seat	Stainless Steel, AISI 420
Cover	Alloy Steel, GR WC9
Strainer Cap	Alloy Steel, GR WC9
Strainer	Stainless Steel, AISI 300
Disc	Stainless Steel, AISI 420
Gasket	Stainless Steel, AISI 304
Studs	SA-193, GR B7
Nuts	SA-194, GR 2H

CAPACITIES – Condensate (lbs/hr)

Size	Model Code (NPT)	Model Code (SW)	Steam Inlet Pressure (PSIG)													
			20	50	100	150	200	300	400	500	600	700	800	900		
1/2"	TD900S-12-N	TD900S-12-SW														
3/4"	TD900S-13-N	TD900S-13-SW	243	411	555	641	700	781	835	874	905	930	951	968		
1"	TD900S-14-N	TD900S-14-SW														
1/2"	TD900LS-12-N	TD900LS-12-SW														
3/4"	TD900LS-13-N	TD900LS-13-SW				181	210	253	290	325	360	381	405	429		
1"	TD900LS-14-N	TD900LS-14-SW														

Notes: WD900S: 1) Minimum recommended working pressure: 20 PSIG.
2) Maximum back pressure not to exceed 80% of inlet pressure (measured in absolute pressure) or trap may not close.

WD900LS: 1) Minimum recommended working pressure: 150 PSIG.
2) Maximum back pressure not to exceed 50% of inlet pressure (measured in absolute pressure) or trap may not close.

Steam Traps

High-Pressure Thermodynamic Steam Trap

TD3600

Thermodynamic

Model	TD3600
Sizes	1/2", 3/4", 1"
Connections	BW, SW, 600# FLG, 1500# FLG
Body Material	Forged Alloy Steel
PMO Max. Operating Pressure	3600 PSIG
TMO Max. Operating Temperature	975 °F @ 3600 psi 1025 °F @ 2220 psi
PMA Max. Allowable Pressure	2220 PSIG @ 1025 °F 3600 PSIG @ 975 °F
TMA Max. Allowable Temperature	1025 °F @ 2220 PSIG

Note: Connections may limit Pressure & Temperature ratings.



Typical Applications

DRIP: TD3600 model steam traps are designed to handle the drainage of condensate from extremely high pressure systems, and are commonly used as drip traps on high-pressure steam mains and steam supply lines. These traps are suitable for outdoor applications that are subject to freezing as well as superheated steam conditions. The complete internal working mechanism can be completely replaced while the trap body remains in line.

How it Works

The disc is the only moving part inside a thermodynamic trap. When steam enters the trap, it creates an internal pressure above the disc that instantly forces the disc to close tightly on the seat, preventing the steam from escaping. The internal steam pressure (holding the disc and seat shut) eventually drops, and the trap re-opens. When condensate enters the trap, it pushes the disc upwards, allowing the condensate to freely discharge. If steam is present, the trap instantly shuts.

Features

- "Quick-Change" seat and disc for easy in-line repair
- High pressure applications up to 3600 PSIG
- Integral strainer to protect trap from contamination
- Hardened stainless steel seat and disc for extended service life even at extremely high pressures
- Steam trap model will operate over the entire pressure range (100-3600 PSIG)
- Suitable for superheated steam
- Freeze-proof when trap is piped in a vertical orientation for complete drainage of condensate
- Trap will function in any orientation (horizontal preferred)

Sample Specification

The steam trap shall be a thermodynamic style with body material in forged alloy steel. Available in size 1/2", 3/4" and 1" Socket Weld, Butt Weld ends or ANSI 600# & 1500# RF flanged connections. Unit shall have hardened repairable stainless steel seat and disc with a removable stainless steel sintered strainer.

Installation and Maintenance

The TD3600 can be installed in any orientation; however, with cap facing upward is preferred for longest service life. For maintenance, ALL internal components are easily removed and completely changed using a replacement kit. The TD3600 contains an integral high pressure sintered strainer for protection against dirt and scale.

Helpful Selection Information

This trap was designed for handling the drainage of condensate from EXTREMELY HIGH PRESSURE systems, with a maximum operating pressure of 3600 PSIG. The TD3600 is available in Socket Weld, Butt Weld and Flange connections from 1/2" through 1".

Options

Customized Flanged Connections:
Specify size and face-to-face dimensions.

Steam Traps

High-Pressure Thermodynamic Steam Trap

TD3600
Thermodynamic

STEAM TRAPS

DIMENSIONS – inches

Weight: 25 lbs.

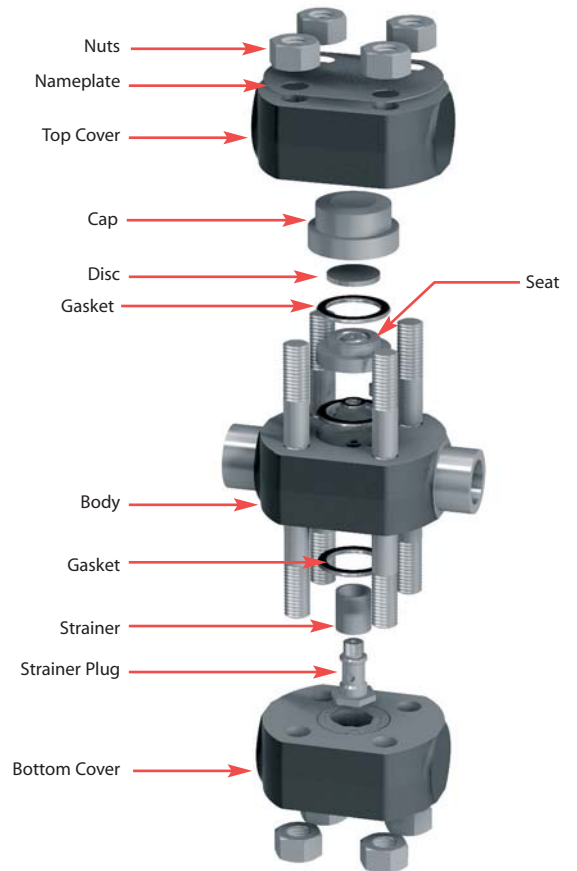
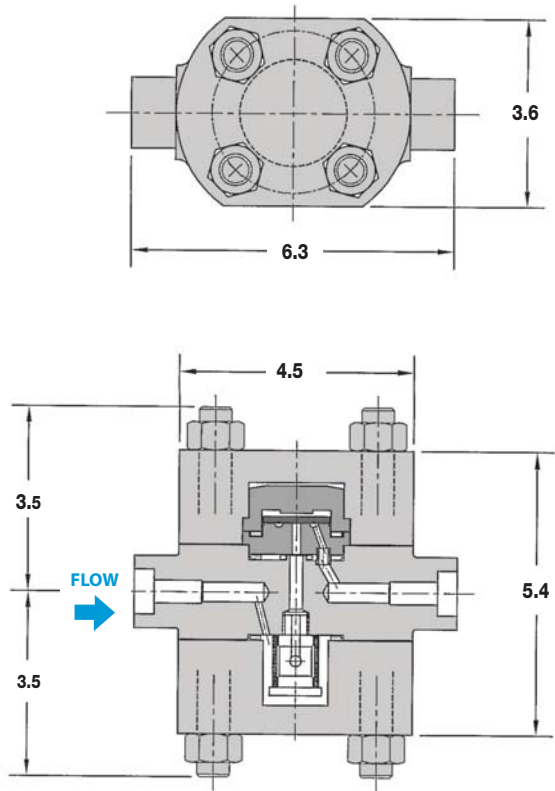

MATERIALS

Body	Forged Alloy Steel, ASTM 182 F22
Seat	Stainless Steel, AISI 420
Cover, top & bottom	Forged Alloy Steel, ASTM 182 F22
Strainer	Sintered Stainless Steel, AISI 300
Disc	Stainless Steel, AISI 420
Gasket	Stainless Steel, AISI 304
Studs	SA-193, GR B16
Nuts	SA-194, GR 4

How to Size / Order

Select working pressure; follow column down to correct capacity (lbs/hr) block. Example:

Application: 380 lbs/hr at 1000 PSIG working inlet pressure

Size/Model: **TD3600**, Specify pipe size and connections (BW, SW, 600# FLG, 1500# FLG)

CAPACITIES – Condensate (lbs/hr)

Size	Conn.	Model Code	Steam Inlet Pressure (PSIG)												
			100	500	1000	1250	1750	2000	2250	2500	2750	3000	3250	3500	3600
1/2"	SW	TD3600-12-SW													
3/4"	SW	TD3600-13-SW	165	290	380	400	435	470	500	525	550	575	595	610	625
1"	SW	TD3600-14-SW													

Note: Maximum back pressure not to exceed 50% of inlet pressure (measured in absolute pressure) or trap may not close. Add note about other connections.

Thermostatic Traps Steam Traps

Industrial type Thermostatic traps are used on drip, process and tracing applications, and use an extremely rugged welded stainless steel bellows. They have excellent air venting capability with a capacity and pressure range for a wide variety of applications. Physical size of a thermostatic trap is considerably smaller than F&T or IB style traps of similar capacity making installation and repair considerably easier. For Example: A Thermostatic trap weighing only 4 pounds is able to replace an F&T trap or an IB trap weighing over 40 pounds. In contrast to an F&T or an IB trap, a single model of a thermostatic trap works over the entire pressure range (from 0-650 PSIG) simplifying model selection. In addition, Thermostatic traps are self-draining eliminating issues with freezing in cold climates. With several repairable and non-repairable models available, thermostatic traps offer many advantages and should be considered.

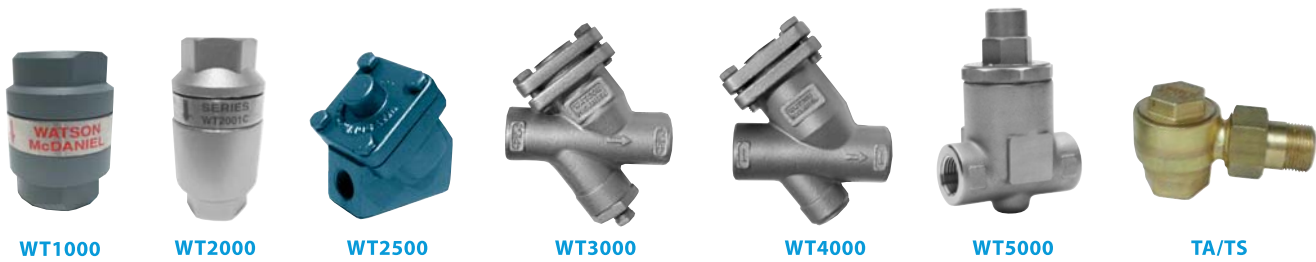

Thermostatic					
Model	Body Material	PMO (PSIG)	Sizes	Connections	Page No.
WT1000	Stainless Steel	300	1/2", 3/4"	NPT	52
WT2000	Stainless Steel	650	1/2", 3/4"	NPT	52
WT3000	Stainless Steel	650	1/2", 3/4"	NPT, SW, FLG	54
WT4000	Stainless Steel	300	3/4", 1"	NPT, SW, FLG	56
WT5000	Stainless Steel	650	3/8" - 1"	NPT, SW	58
TA/TS	Brass	25/125	1/2", 3/4"	NPT	60
WT2500	Cast Iron	250	1/2", 3/4"	NPT	62

Typical Applications for Thermostatic Steam Traps

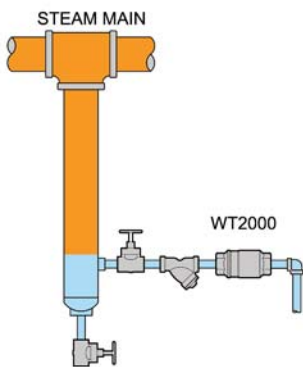

Steam Main Drip

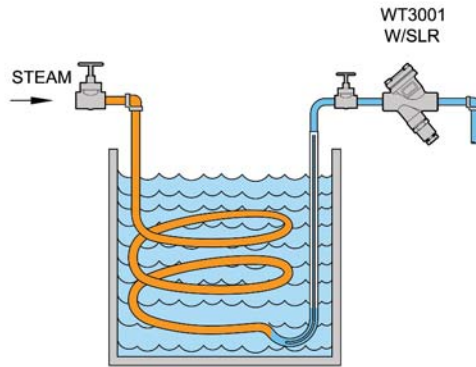

Plating Tank (Batch Process)

With steam trap positioned above condensate collection point using the Steam Lock Release option (SLR)

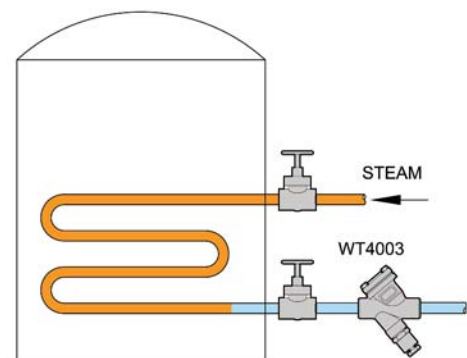

Outdoor Storage Tank (Batch Process)

Introduction

THERMOSTATIC STEAM TRAPS

Operation:

The bellows type thermostatic trap contains a fluid-filled thermal element (bellows). The operation of this thermal element is governed by the volumetric thermal expansion of the fluid inside the bellows as it changes states. There is no adjustment required for this trap as the fluid inside the bellows is chosen for its quick response to the change in temperature between steam and condensate at various pressures. The operation of the bellows follows the steam saturation curve, always discharging condensate a few degrees cooler than the steam temperature.

During start-up, when the system is cold, the bellows is retracted and the valve plug is lifted off the seat allowing air and condensate to be discharged from the system. As hot steam approaches the thermal element in the trap, the fluid inside the bellows vaporizes and expands, closing the valve tightly. As long as steam is present, the valve will remain closed. Only when subcooled condensate or air is present will the valve open.

Watson McDaniel thermal element traps offer wide operating pressure ranges, rugged welded stainless steel bellows, and various orifice sizes, making them a great choice for a majority of applications.

Sub-cool:

The sub-cooling of condensate prior to discharge can have certain beneficial effects. In the majority of tracing applications, the sub-cooling of condensate is highly desirable because of the additional energy that is extracted from the Hot condensate. If the trap did not sub-cool condensate, this energy would be wasted.

In Batch style process applications such as jacketed kettles, plating tanks and heating of outdoor storage tanks, the sub-cooling of condensate is generally not a factor to consider since the amount of condensate back-up requires less than 1% of the heat transfer surface area and is therefore considered negligible. So a heat exchanger with 50 square feet of surface area requires only 1/2 a square foot of surface area to sub-cool the condensate. In a Continuous process application that exhibit rapid changes in steam pressures, steam traps requiring sub-cool could lead to additional condensate back up. This scenario is typical in instantaneous hot water heaters using a shell & tube heat exchanger with temperature control valves. The steam pressure in the heat exchanger can drop extremely fast when the water demand changes. In this case, additional sub-cooling of the condensate is required before it will discharge. In some cases, this may be acceptable, but in general, only F&T traps are recommended for process with rapid changes in steam pressures since they always discharge condensate immediately as it is formed. In addition, traps that sub-cool condensate have a softer discharge since less flash steam is generated in the return line.

- A) AIR** When air, which is cooler than steam, is present, the bellows is retracted and the seat is open, allowing large quantities of air to be discharged.

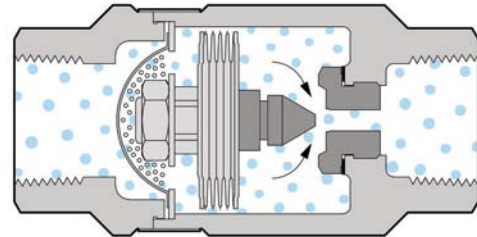

- B) CONDENSATE** When condensate, which is cooler than steam, is present, the bellows retracts and the seat opens, allowing condensate to be discharged.

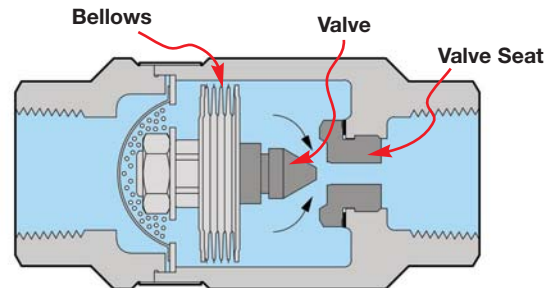

- C) STEAM** When steam reaches the trap, the bellows expands, closing off the seat and preventing the steam from escaping.

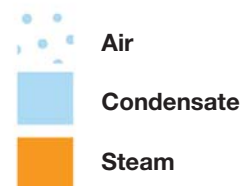
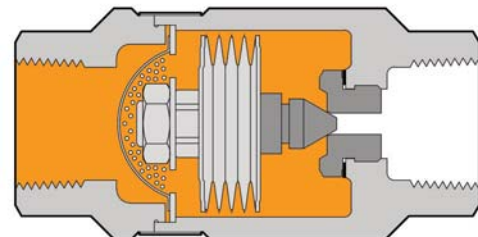

Non-Repairable (Seal-welded Stainless Steel Body)

The **WT1000** & **WT2000** Thermostatic Steam Traps have Stainless Steel, seal-welded bodies and are Non-repairable.

The **WT1000** is specifically intended for Drip and Tracing Applications.

The **WT2000** is substantially larger in capacity than the WT1000. It can be used for Batch Type Process Applications as well as for Drip and Tracing. Also used as an Air Vent; Model AV2000.



Repairable (4-Bolt Cover)

The **WT3000** & **WT4000** Thermostatic Steam Traps have cast Stainless Steel bodies and are fully-repairable.

The **WT3000** has an identical capacity to the WT2000; commonly used for Process Applications but can also be used for drip and tracing if a repairable design is desired.

The **WT4000** has substantially higher capacity than the WT3000; used for larger Process Applications.

The **WT2500**, with a cast iron body, is an economical alternative to the WT3000 and is identical in capacity; however, its limited to 250 PSIG. It is likewise fully-repairable and can be used where cast iron is acceptable.

The **TA/TS Series** are referred to as Thermostatic Radiator Traps. They have brass bodies and are fully-repairable; predominantly used in the HVAC industry for steam traps and air vents.



Temperature Adjustable Bi-Metal

The **WT5000** Bi-Metal Steam Trap has a Stainless Steel body, is fully-repairable and intended for Steam Tracing Applications.

Its unique feature is a temperature-adjustable Bi-Metal element which allows for precise control of condensate discharge temperature (temperature adjustment can be made in the field). This is a desirable feature for tracing, so that condensate discharge temperature can be controlled to suit a particular application.



Model	WT1000 (Non-Repairable)
Sizes	1/2", 3/4"
Connections	NPT
Body Material	Stainless Steel
PMO Max. Operating Pressure	300 PSIG
TMO Max. Operating Temperature	Saturated Steam Temperature
PMA Max. Allowable Pressure	1032 PSIG @ 100°F
TMA Max. Allowable Temperature	750°F @ 800 PSIG



Typical Applications

DRIP, TRACING: The **WT1000** is a low capacity thermostatic trap ideally sized for steam tracing. Thermostatic traps are small, light weight and have excellent air discharging capabilities. Discharging air at start-up allows steam to quickly enter the system. Trap body is permanently seal welded together and therefore non-repairable. Contains an extremely strong and rugged precision welded Stainless Steel thermal element. Its small discharge orifice, which makes it an optimal size trap for both drip and tracing applications, is susceptible to clogging depending on system conditions, therefore, a separate strainer should be installed.

How It Works

This thermostatic trap contains a welded stainless steel thermal element that expands when heated and contracts when cooled to 5°F below saturated steam temperature. When air or sub-cooled condensate are present, the trap is in the open discharge position. When steam reaches the trap, the element expands and closes off tightly.

Features

- Excellent at discharging air which allows steam to enter system quickly; extremely important during start-up
- Welded stainless steel thermal element resists shock from water hammer
- Freeze-proof when trap is installed in a vertical orientation allowing for complete condensate drainage
- Stainless steel Barstock body
- In the unlikely event of bellows failure; trap discharge remains open

Installation & Maintenance

Trap can be installed in any orientation. The WT1000 steam trap body is seal-welded and therefore non-repairable. If a new trap is required, remove from line and replace. This product cannot be welded in-line or failure of the thermal element due to excess heat may occur. Available in NPT threaded connections only.

Sample Specification

The steam trap shall be of thermostatic type with stainless steel body and stainless steel thermal element.

MATERIALS

Trap Housing	Stainless Steel, AISI 304L
Thermal Element	Stainless Steel, 300 Series
Valve	Stainless Steel, AISI 440C

DIMENSIONS – inches

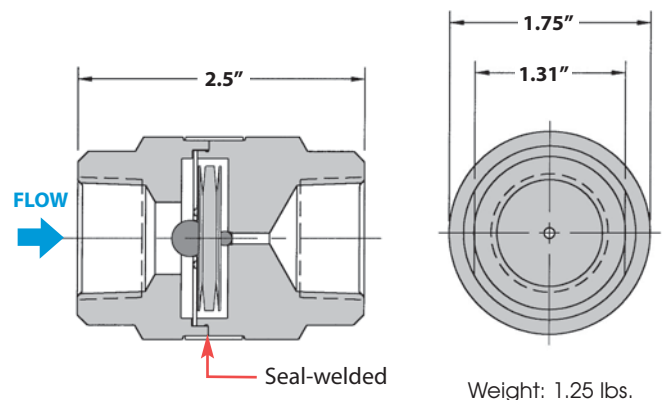

CAPACITIES – Condensate (lbs/hr)

Size	Model Code	Steam Inlet Pressure (PSIG)									
		5	10	20	50	100	125	150	200	250	300
1/2"	WT1000-12-N	95	140	195	305	435	485	530	610	685	750
3/4"	WT1000-13-N										

Steam Traps

Thermostatic Steam Trap

(Non-Repairable)

WT2000
Thermostatic

Model	WT2000 (Non-Repairable)
Sizes	1/2", 3/4"
Connections	NPT
Body Material	Stainless Steel
PMO Max. Operating Pressure	650 PSIG
TMO Max. Operating Temperature	Saturated Steam Temp.
PMA Max. Allowable Pressure	1032 PSIG @ 100°F
TMA Max. Allowable Temperature	750°F @ 800 PSIG



Typical Applications

DRIP, TRACING, PROCESS: The **WT2000** is a general purpose medium-capacity thermostatic trap that can be used for steam tracing, as a drip trap on steam mains and steam supply lines, as well as for process applications. They are also commonly used as an Air Vent on heat exchangers or at the ends of steam mains. Thermostatic traps are small, light weight, operate over a wide pressure range, and have excellent air handling capabilities. Discharging air at start-up allows steam to quickly enter the system. All stainless steel construction and integral strainer, make the WT2000 an excellent choice for a variety of applications. Trap body is permanently seal welded together and therefore non-repairable. Contains an extremely strong and rugged precision welded Stainless Steel thermal element which is highly resistant to waterhammer.

How It Works

This thermostatic trap contains a welded stainless steel thermal element that expands when heated and contracts when cooled to 5°F below saturated steam temperature. When air or sub-cooled condensate are present, the trap is in the open discharge position. When steam reaches the trap, the element expands and closes off tightly.

Features

- Thermostatic traps are excellent at discharging air, which allows steam to enter quickly; extremely important during start-up
- Integral strainer to protect trap from contamination
- Welded stainless steel thermal element resists shock from waterhammer
- Freeze-proof when trap is installed in a vertical orientation allowing for complete condensate drainage
- Body is produced from stainless steel investment casting
- Hardened stainless steel seat for extended service life
- Will operate at steam pressures up to 650 PSIG

Sample Specification

Steam trap shall be of thermostatic type with stainless steel body, thermal element, internal screen, and hardened valve and seat.

Installation and Maintenance

Trap can be installed in any position. The WT2000 steam trap body is seal-welded and therefore non-repairable. If a new trap is required, remove from line and replace. Cannot be welded in-line or failure of the thermal element may occur. Available in NPT threaded connections only.

Helpful Selection Information

Two orifice sizes are available: The 3/16" orifice should be used on all drip and tracing applications as well as small process applications with lower condensate loads. The 5/16" orifice is available to be used on process applications if additional capacity is required.

Options

- **Special Bellows Option;** available upon request:
 - Fail-closed Bellows (standard bellows fails in open position)
 - 43°F Sub-cool Bellows (Note: Standard bellows are designed for approximately 5°F sub-cool temperature)
- **SLR = Steam lock release**
- Standard models contain a non-cleanable strainer screen. Also available without screen where it is desirable to flush dirt and scale thru the trap. Recommend WT2003 with larger orifice if used without strainer.

Steam Traps

Thermostatic Steam Trap (Non-Repairable)

WT2000
Thermostatic

STEAM TRAPS

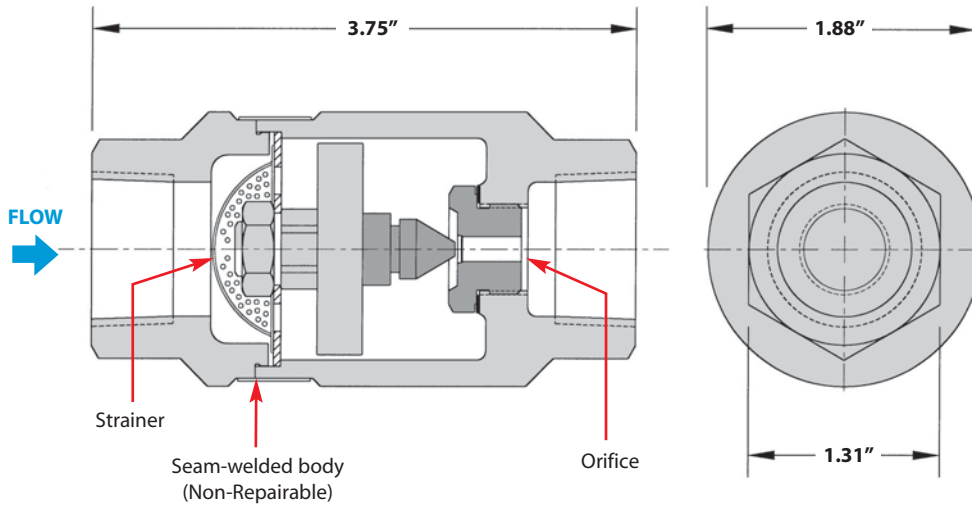

Weight: 1.5 lbs.

MATERIALS

Trap Housing	Stainless Steel, ASTM A351-CF3
Thermal Element	Stainless Steel
Valve & Seat	Stainless Steel, AISI 416
Strainer Screen	Stainless Steel

How to Size / Order

Select working pressure; follow column down to correct capacity (lbs/hr) block. Example:

Application: 1827 lbs/hr at 100 PSIG working inlet pressure
Size/Model: **WT2001-12-N**, 1/2" NPT, 3/16" orifice

CAPACITIES – Condensate (lbs/hr)

Size	Model Code	Orifice Size	Steam Inlet Pressure (PSIG)														
			5	10	20	50	100	125	150	200	250	300	350	400	500	600	650
1/2"	WT2001-12-N	3/16"	441	625	882	1391	1827	1969	2095	2305	2483	2636	2777	2903	3129	3323	3413
3/4"	WT2001-13-N		903	1271	1811	2861	3754	4043	4300	4730	5093	5413	5702	5959	6421	6820	7004
1/2"	WT2003-12-N	5/16"	903	1271	1811	2861	3754	4043	4300	4730	5093	5413	5702	5959	6421	6820	7004
3/4"	WT2003-13-N		903	1271	1811	2861	3754	4043	4300	4730	5093	5413	5702	5959	6421	6820	7004

Note: 3/16" orifice should be used on all drip and tracing applications.

Back Pressure as Percentage of Inlet Pressure	10	20	25	30	40	50	60	70	80	90
Percentage Decrease in Trap Capacity	0	0	0	2	5	12	20	30	40	55

Steam Traps

Thermostatic Steam Trap

(Repairable)

WT3000
Thermostatic

Model	WT3000 (Repairable)
Sizes	1/2", 3/4"
Connections	NPT, SW, FLG
Body Material	Stainless Steel
Options	Strainer, Blowdown Valve
PMO Max. Operating Pressure	650 PSIG
TMO Max. Operating Temperature	Saturated Steam Temp.
PMA Max. Allowable Pressure	906 PSIG @ 100°F
TMA Max. Allowable Temperature	750°F @ 725 PSIG



Typical Applications

DRIP, TRACING, PROCESS: The **WT3000** is a general purpose medium capacity thermostatic trap that can be used for steam tracing; as a drip trap on steam mains and steam supply lines; as well as for process applications. All internal working components can be replaced while the trap body remains in-line. Thermostatic traps are small, light weight, operate over a wide pressure range, and have excellent air handling capabilities. Discharging air at start-up allows steam to quickly enter the system. All stainless steel construction and integral strainer option make the WT3000 an excellent choice for a variety of applications. Contains an extremely strong and rugged precision welded Stainless Steel thermal element which is highly resistant to waterhammer.

How It Works

This thermostatic trap contains a welded stainless steel thermal element that expands when heated and contracts when cooled to 5°F below saturated steam temperature. When air or sub-cooled condensate are present, the trap is in the open discharge position. When steam reaches the trap, the element expands and closes off tightly.

Features

- The thermal element and seat can be easily removed and replaced in minutes with the trap body still in-line
- Operates at steam pressures up to 650 PSIG
- Thermostatic traps are excellent at discharging air, which allows steam to enter quickly; extremely important during start-up
- Welded stainless steel thermal element resists shock from waterhammer
- Freeze-proof when trap is installed in a vertical orientation allowing for complete condensate drainage
- Body is produced from stainless steel investment casting
- Hardened stainless steel seat for extended service life
- Available with integral strainer and blowdown valve

Sample Specification

The steam trap shall be of a thermostatic type with stainless steel body, thermal element and internal strainer. Trap must be in-line repairable with a bolt-on type cover that is sealed with a spiral wound Stainless Steel AISI 316 gasket. Seat and valve to be hardened stainless steel.

Installation and Maintenance

Trap can be installed in any orientation. All internal working components are extremely easy to replace and can be performed while the trap body remains connected in-line. Repair kit includes ALL parts to fully rebuild the steam trap including thermal element, seat and gasket. The WT3000S model comes with an optional strainer. WT3000SB comes with optional blowdown valve for flushing dirt and scale from strainer.

Helpful Selection Information

Two orifice sizes are available: The 3/16" orifice should be used on all drip and tracing applications as well as small process applications with lower condensate loads. The 5/16" orifice is available to be used on process applications if additional capacity is required.

Options

Strainer, blowdown valve, steam lock release and special bellows available.

S = Strainer (**WT3001S**)

SB = Strainer and blowdown valve (**WT3001SB**)

SLR = Steam lock release

Special Bellows Option; available upon request:

- Fail-closed Bellows (standard bellows fails in open position)
- 43°F Sub-cool Bellows (Note: Standard bellows are designed for approximately 5°F sub-cool temperature)

How to Size / Order

Refer to the Capacity Chart to determine which model, the WT3001 or WT3003 is required to satisfy the condensate load based on steam inlet pressure.

Example:

Application: 3754 lbs/hr at 100 PSIG steam inlet pressure
Size/Model: **WT3003S**, 5/16" orifice with strainer,
Specify size & connections (NPT, SW, FLG)

Example Model Codes:

WT3003S-13-N 3/4" NPT with strainer, and 5/16" orifice.

WT3001SB-12-N 1/2" NPT with strainer and blowdown valve,
3/16" orifice

Steam Traps

Thermostatic Steam Trap

(Repairable)

WT3000

Thermostatic

STEAM TRAPS

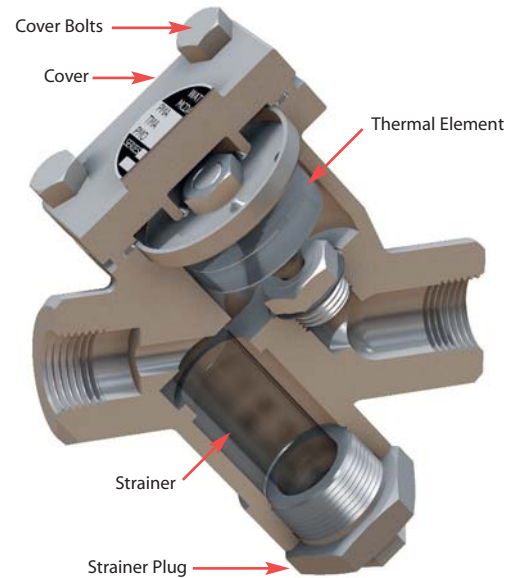
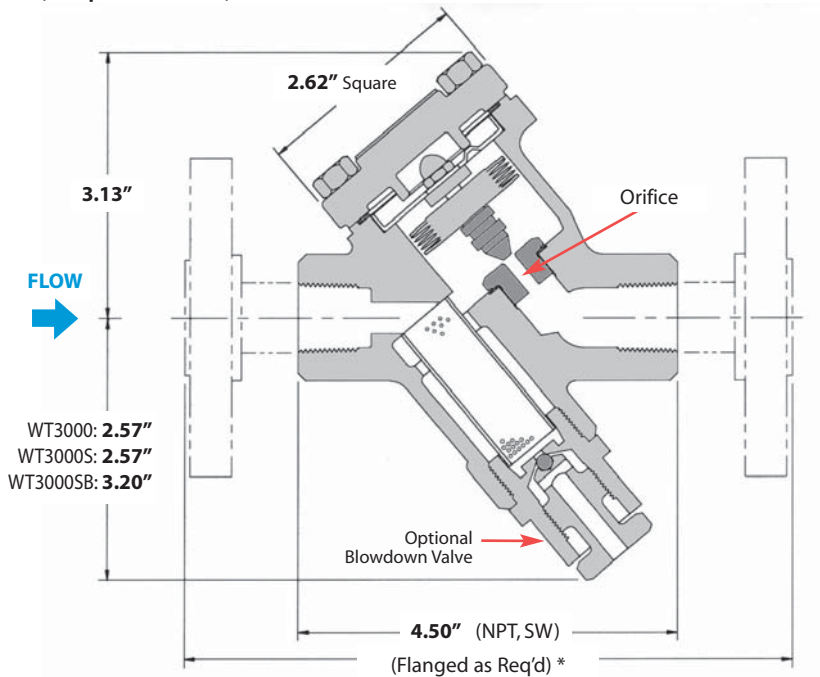

Weight: 4.5 lbs.

* Flanged face-to-face dimension 9" standard.
For custom sizes consult factory (9" minimum).

Size/Connection*	Model Code	Orifice Size	Description
1/2" NPT	WT3001-12-N	3/16"	No Strainer
3/4" NPT	WT3001-13-N	3/16"	No Strainer
1/2" NPT	WT3001S-12-N	3/16"	Strainer
3/4" NPT	WT3001S-13-N	3/16"	Strainer
1/2" NPT	WT3001SB-12-N	3/16"	Strainer & Blowdown
3/4" NPT	WT3001SB-13-N	3/16"	Strainer & Blowdown
1/2" NPT	WT3003-12-N	5/16"	No Strainer
3/4" NPT	WT3003-13-N	5/16"	No Strainer
1/2" NPT	WT3003S-12-N	5/16"	Strainer
3/4" NPT	WT3003S-13-N	5/16"	Strainer
1/2" NPT	WT3003SB-12-N	5/16"	Strainer & Blowdown
3/4" NPT	WT3003SB-13-N	5/16"	Strainer & Blowdown

* For Socket Weld Connection change **N** to **SW**

MATERIALS

Cover & Body	Stainless Steel, AISI 316L
Thermal Element	Stainless Steel, AISI 300
Valve & Seat	Stainless Steel, AISI 416
Cover Gasket	Stainless Steel, AISI 316
Seat Gasket	Stainless Steel, AISI 316
Cover Bolts	Steel, ASTM A193 GR B7 Nickel Plated
Strainer*	0.046 Perforated Stainless Steel AISI 304
Blowdown Valve*	Stainless Steel AISI 303

* Strainer and blowdown valve are optional

CAPACITIES — Condensate (lbs/hr)

Model	Orifice Size	Steam Inlet Pressure (PSIG)														
		5	10	20	50	100	125	150	200	250	300	350	400	500	600	650
WT3001	3/16"	441	625	882	1391	1827	1969	2095	2305	2483	2636	2777	2903	3129	3323	3413
WT3003	5/16"	903	1271	1811	2861	3754	4043	4300	4730	5093	5413	5702	5959	6421	6820	7004

Back Pressure as Percentage of Inlet Pressure	10	20	25	30	40	50	60	70	80	90
Percentage Decrease in Trap Capacity	0	0	0	2	5	12	20	30	40	55

Steam Traps

Thermostatic Steam Trap

(Repairable)

WT4000
Thermostatic

Model	WT4000 (Repairable)
Sizes	3/4", 1"
Connections	NPT, SW, FLG
Body Material	Stainless Steel
Options	Strainer, Blowdown Valve
PMO Max. Operating Pressure	300 PSIG
TMO Max. Operating Temperature	Saturated Steam Temperature
PMA Max. Allowable Pressure	906 PSIG @ 100°F
TMA Max. Allowable Temperature	750°F @ 725 PSIG



Typical Applications

PROCESS: The **WT4000** is a high capacity version of the WT3000, for removing condensate and air from larger process applications. This steam trap is fully repairable while the body remains in-line. Like all thermostatic traps, they are small, light weight, operate over a wide pressure range, and have excellent air handling capabilities. Discharging air at start-up allows steam to quickly enter the system. All stainless steel construction and integral strainer option make the WT4000 an excellent choice for most process applications. Contains an extremely strong and rugged precision welded Stainless Steel thermal element which is highly resistant to waterhammer.

How It Works

This thermostatic trap contains a welded stainless steel thermal element that expands when heated and contracts when cooled to 5°F below saturated steam temperature. When air or sub-cooled condensate are present, the trap is in the open discharge position. When steam reaches the trap, the element expands and closes off tightly.

Features

- The thermal element and seat can be easily removed and replaced in minutes with the trap body still in-line
- Operates at steam pressures up to 300 PSIG
- Thermostatic traps are excellent at discharging air, which allows steam to enter quickly; extremely important during start-up
- Welded stainless steel thermal element resists shock from waterhammer
- Freeze-proof when the trap is installed in a vertical orientation allowing for complete condensate drainage
- Body is produced from stainless steel investment casting
- Hardened stainless steel seat for extended service life
- Available with integral strainer and blowdown valve

Sample Specification

The steam trap shall be of thermostatic type with stainless steel body, thermal element, and internal strainer. Trap must be in-line repairable with a bolt-on type cover that is sealed with a spiral wound Stainless Steel AISI 316 gasket. Seat and valve to be hardened stainless steel.

Installation and Maintenance

Trap can be installed in any orientation. All internal working components are extremely easy to replace and can be performed while the trap body remains connected in-line. Repair kit includes ALL parts to fully rebuild the steam trap including thermal element, seat and gasket. The WT4000 does not contain a strainer. The WT4000S contains a strainer. WT4000SB contains a blowdown valve for flushing dirt and scale from strainer.

Helpful Selection Information

Two orifice sizes are available: 7/16" standard capacity and 5/16" reduced capacity. Select these models for steam systems with maximum working pressure of 300 PSIG.

Options

Strainer, blowdown valve, and steam lock release.

S = Strainer (**WT4001S**)

SB = Strainer and blowdown valve (**WT4001SB**)

SLR = Steam lock release

Customized flanged connections: Specify size, face-to-face dimensions.

How to Size / Order

Refer to the Capacity Chart to determine which model, the WT4001 or WT4003 is required to satisfy the condensate load based on steam inlet pressure.

Example:

Application: 5610 lbs/hr at 100 PSIG steam inlet pressure

Size/Model: **WT4001S**, 5/16" orifice, and strainer
Specify size & connections (NPT, SW, FLG)

Example Model Codes:

WT4001S-13-N 3/4" NPT with strainer, and 5/16" orifice

WT4003SB-14-N 1" NPT with strainer and blowdown valve, 7/16" orifice

Steam Traps

Thermostatic Steam Trap

(Repairable)

WT4000

Thermostatic

STEAM TRAPS

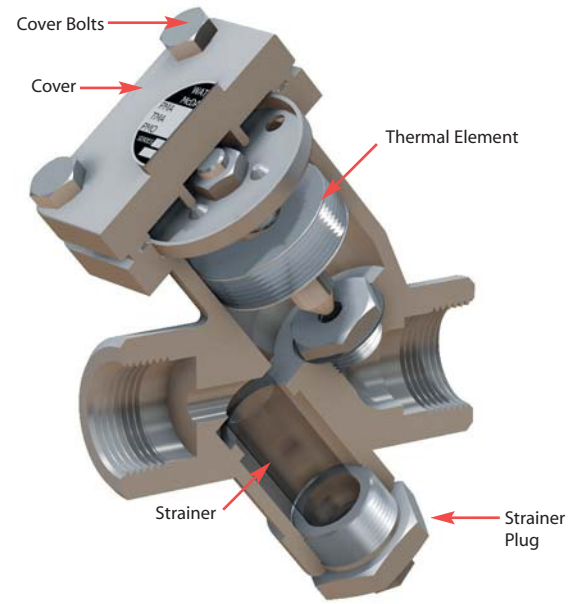
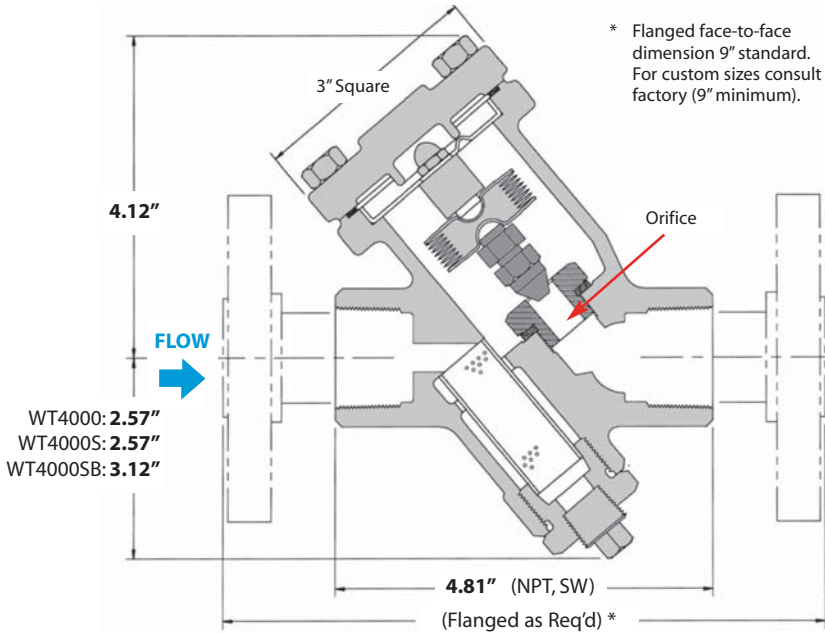

Weight: 4.5 lbs.

Size/Connection*	Model Code	Orifice Size	Description
3/4" NPT	WT4001-13-N	5/16"	No Strainer
1" NPT	WT4001-14-N	5/16"	No Strainer
3/4" NPT	WT4001S-13-N	5/16"	Strainer
1" NPT	WT4001S-14-N	5/16"	Strainer
3/4" NPT	WT4001SB-13-N	5/16"	Strainer & Blowdown
1" NPT	WT4001SB-14-N	5/16"	Strainer & Blowdown
3/4" NPT	WT4003-13-N	7/16"	No Strainer
1" NPT	WT4003-14-N	7/16"	No Strainer
3/4" NPT	WT4003S-13-N	7/16"	Strainer
1" NPT	WT4003S-14-N	7/16"	Strainer
3/4" NPT	WT4003SB-13-N	7/16"	Strainer & Blowdown
1" NPT	WT4003SB-14-N	7/16"	Strainer & Blowdown

* For Socket Weld Connection change N to SW

MATERIALS

Body	Stainless Steel, AISI 316L
Cover	Stainless Steel, AISI 316L
Cover Gasket	Spiral Wound Stainless Steel, AISI 316
Cover Bolts	Steel, ASTM A193 GR B7 Nickel Plated
Thermal Element	Stainless Steel, AISI 302
Valve & Seat	Hardened Stainless Steel, AISI 416
Seat Gasket	Stainless Steel, AISI 316
Strainer*	0.046 Perforated Stainless Steel AISI 304
Blowdown Valve*	Stainless Steel AISI 300

* Strainer and blowdown valve are optional

CAPACITIES — Condensate (lbs/hr)

Model	Orifice Size	Steam Inlet Pressure (PSIG)											
		1	2	5	10	20	50	100	125	150	200	250	300
WT4001	5/16"	605	855	1350	1910	2705	4275	5610	6045	6425	7070	7615	8095
WT4003	7/16"	940	1325	2095	2960	4190	6620	8695	9365	9950	10955	11800	12540

Back Pressure as Percentage of Inlet Pressure	10	20	25	30	40	50	60	70	80	90
Percentage Decrease in Trap Capacity	0	0	0	2	5	12	20	30	40	55

Steam Traps

Bi-Metal Adjustable Discharge Temperature

(Repairable)

WT5000

Bi-Metal

Model	WT5000 (Bi-Metal)
Sizes	3/8", 1/2", 3/4", 1"
Connections	NPT, SW
Body Material	Stainless Steel
PMO Max. Operating Pressure	650 PSIG
TMO Max. Operating Temperature	662°F
PMA Max. Allowable Pressure	900 PSIG
TMA Max. Allowable Temperature	800°F



Typical Applications

TRACING: The WT5000 is specifically designed for steam tracing applications where accurate and adjustable control of condensate discharge temperature is desired. Can be used where a temperature sensitive medium is being transferred in piping system or held in a storage vessel and standard steam tracing methods may not be adequate to maintain specific product temperatures. Having the ability to adjust the condensate discharge temperature would allow for accurate temperature control of the product being traced. The significant feature of the WT5000 is that the condensate discharge temperature is easily field-adjustable.

How It Works

Bi-metallic plates of dissimilar metals which are connected to the valve seat assembly respond to temperature variations. At relatively cool conditions, the trap is open for the discharge of condensate. When the temperature of the condensate is equal to or higher than the set temperature, the metals react and expand, closing the trap. External field-adjustability of the bi-metal element allows control of the condensate discharge temperature.

The condensate temperature can be field adjusted as follows:

To **INCREASE** the temperature, turn the adjuster screw:
 → **COUNTERCLOCKWISE**

To **DECREASE** the temperature, turn the adjuster screw:
 → **CLOCKWISE**

Note: The lower the set temperature, the more condensate will back-up in front of the trap inlet connection. Therefore, consideration should be given to providing adequate piping to accommodate any such back-up.

Features

- Excellent for various steam tracing and small process applications using the additional energy (sensible heat) of the hot condensate
- Field-adjustable bi-metal element allows control of condensate discharge temperature
- Internal screen and seat/plug design help prevent pipe scale and debris from accumulating on seating surfaces to provide trouble-free operation
- In-line repairable

Sample Specification

The steam trap shall be a bi-metal type with stainless steel body, seat, valve plug and bimetallic element. Bi-metal element shall be externally adjustable for control of condensate discharge temperature. Trap must be in-line repairable with a replaceable bi-metal element, valve plug and seat.

Installation and Maintenance

Trap can be installed in any orientation. The body is made from stainless steel and is fully repairable while the steam trap remains in-line. If the trap fails, remove the cover and replace the internal working components. Repair kit includes bimetallic element (including valve stem and plug), seat and gasket.

Helpful Selection Information

Available in 3/8" through 1" NPT and socket weld connections. Select this model for steam systems with maximum working pressure of 650 PSIG.

Size/Connection	Model Code	Weight lbs	Cross Reference TLV
3/8" NPT	WT5000-11-N	3.0	LEX3N-TZ
1/2" NPT	WT5000-12-N		
3/4" NPT	WT5000-13-N		
1" NPT	WT5000-14-N		
3/8" SW	WT5000-11-SW	3.0	LEX3N-TZ
1/2" SW	WT5000-12-SW		
3/4" SW	WT5000-13-SW		
1" SW	WT5000-14-SW		

MATERIALS

Body and Cover	304 Stainless Steel
Bimetal Element	GB14
Valve Seat	420 Stainless Steel
Valve Stem	420 Stainless Steel

Steam Traps

Bi-Metal Adjustable Discharge Temperature

WT5000
Bi-Metal

STEAM TRAPS

(Repairable)

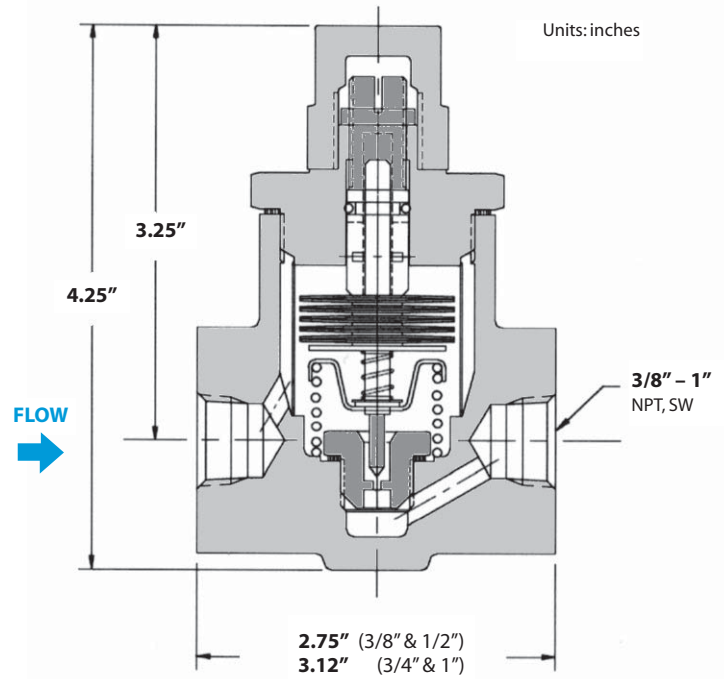
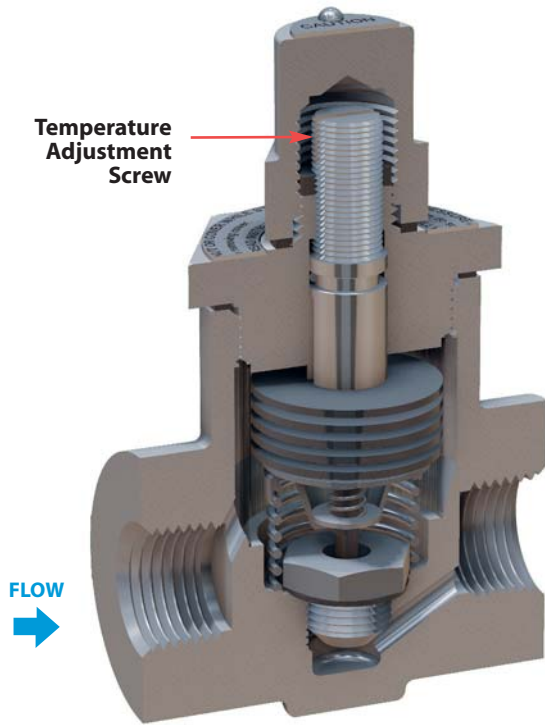

Notes:

- 1) Capacities in chart are based on discharging condensate to atmospheric pressure (0 PSIG).
- 2) **Initial Opening Temperature = T** is the temperature at which the trap just begins to open. A negligible amount of condensate flow takes place at this temperature. It is adjustable between 120°F and 390°F.
- 3) **Initial Opening Temperature** must be at least 27 degrees below the saturated steam temperature to prevent possible steam loss.
- 4) When the condensate cools below the initial opening temperature, the Bi-metal mechanism opens further, increasing trap capacity. Trap capacity can be adjusted up to the max value given in the chart.
- 5) For instructions on setting the trap discharge temperature and capacity, refer to the Watson McDaniel Installation and Maintenance Guide.
- 6) *Example:* A WT5000 trap with 125 PSIG Steam Inlet Pressure can be set to an Initial Opening Temperature between 120°F and 326°F. It can pass up to 413 lbs/hr when the temperature of the condensate is 80°F below the initial opening temperature (T-80°F).

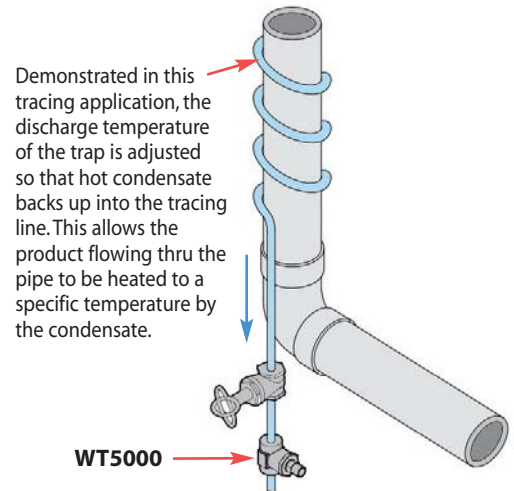

T = Initial Opening Temperature of the Trap can be set from 120°F to 390°F

Trap Capacities at Various Inlet Pressures – Lbs/hr @ T, T-20°F, T-40°F, T-60°F, T-80°F

Condensate Discharge Temperature	Saturated Steam Temperature (°F) (based on given steam inlet pressure)															
	250	274	298	338	353	366	388	406	422	436	448	460	470	489	497	
T can range from 120°F to 390°F. T range for Steam Inlet Pressure of 15 PSIG is 120 to 223°F	Maximum Initial Opening Temperature must be at least 27 degrees below saturated steam temperature. (390°F max)															
	223	247	271	311	326	339	361	379	390							390
	Steam Inlet Pressure (PSIG)															
	15	30	50	100	125	150	200	250	300	350	400	450	500	600	650	
T = Initial Opening Temp.	0	0	0	0	0	0	0	0	0	0	0	0	0	0	0	
T-20°F 20° below Initial Opening Temperature	56	70	102	144	161	177	204	228	250	270	289	306	323	354	368	
T-40°F 40° below Initial Opening Temperature	116	164	212	300	336	368	425	475	520	562	600	637	671	735	756	
T-60°F 60° below Initial Opening Temperature	134	190	245	346	387	424	490	548	600	648	693	735	775	849	883	
T-80°F 80° below Initial Opening Temperature	143	202	261	370	413	453	523	584	640	691	739	784	826	905	942	

Steam Traps

Thermostatic Steam Trap

TA25B, TA125 TS25B, TS125

(Repairable)

Model	TA25B, TA125, TS25B, TS125
Sizes	1/2", 3/4"
Connections	NPT
Body Material	Brass
PMO Max. Operating Pressure	TA25B, TS25B 25 PSIG TA125, TS125 125 PSIG
TMO Max. Operating Temperature	Saturated Steam Temperature
PMA Max. Allowable Pressure	125 PSIG up to 450°F
TMA Max. Allowable Temperature	450°F @125 PSIG

TA Type • Right-Angle Connection

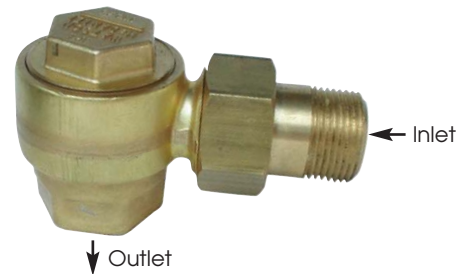

TS Type • Straight-thru Connection



Typical Applications

TA & TS type steam traps are predominantly used in the HVAC industry. They are referred to as radiator traps because the quick-disconnect right angle connection of the TA Type is found on most steam radiator installations. The TS Type offers a straight-through connection alternative. TA and TS Series radiator traps were designed specifically for removing condensate and air from 2-pipe steam heating systems. Their excellent air-handling capabilities, compact size, and economical cost make them a great choice for air vents on heat exchangers or for steam trap applications on OEM equipment. Contains an extremely strong and rugged precision-welded Stainless Steel thermal element which is highly resistant to waterhammer.

How It Works

This thermostatic trap contains a welded stainless steel thermal element that expands when heated and contracts when cooled. When air and condensate are present the trap is in the open discharge position. When steam reaches the trap the element expands and closes off tightly.

Features

- Excellent air handling capability
- In-line repairable
- Welded stainless steel thermal element
- Stainless seat on TA125 & TS125
- High thermal efficiency

Sample Specification

The steam trap shall be of thermostatic type with brass or bronze body and stainless steel thermal element. Trap must be in-line repairable.

Installation and Maintenance

Trap can be installed in any orientation. The bodies are made from a high-quality brass forging and are easily repairable while the steam trap remains in-line by removing the cap and replacing the seat and thermal element. Repair kit includes thermal element, seat and gasket.

Steam Traps

Thermostatic Steam Trap

(Repairable)

TA25B, TA125
TS25B, TS125

STEAM TRAPS

TA Type • Right-Angle Connection

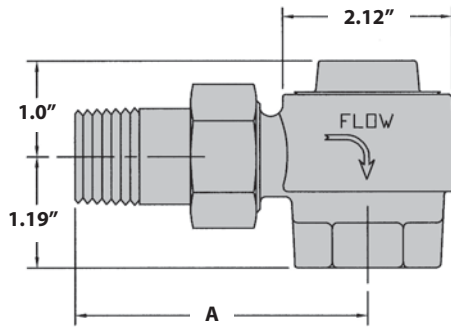

TS Type • Straight-thru Connection

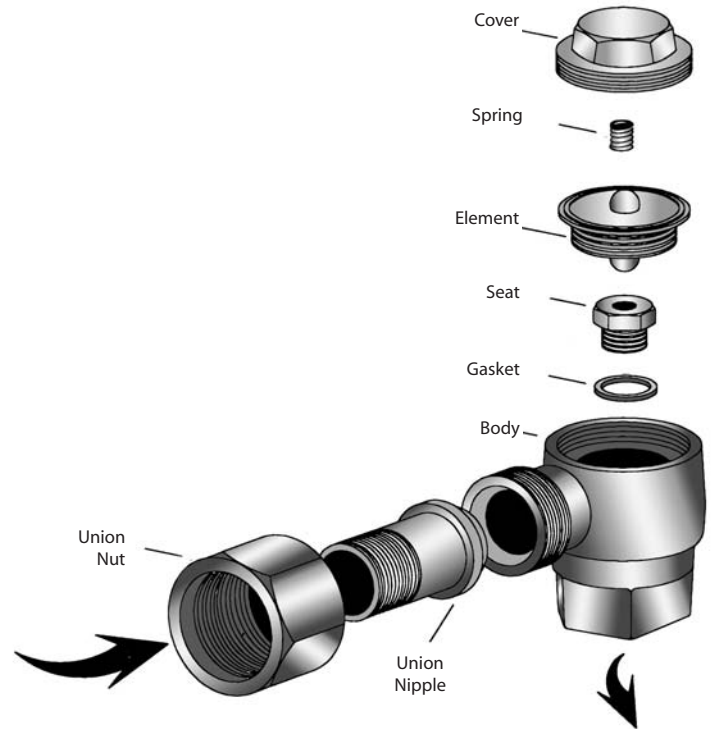
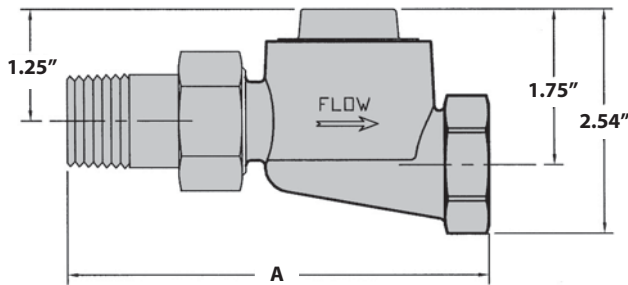

DIMENSIONS & WEIGHTS – inches

Model	Pipe Size	A	Weight (lbs)
TA25B, TA125	1/2"	2.1875	1.5
TA25B, TA125	3/4"	3.062	1.5
TS25B, TS125	1/2"	4.500	1.5
TS25B, TS125	3/4"	4.625	1.5

Note: Other Union Connections and Lengths are available; consult factory.

How to Size / Order

Select differential pressure; follow column down to correct capacity (lbs/hr) block. Example:

Application: 2100 lbs/hr at 40 PSI differential pressure

Size/Model: 3/4" TA125

CAPACITIES – Condensate (lbs/hr)

Size	Model Code	PMO (PSIG)	Steam Inlet Pressure (PSIG)				
			15	25	40	65	125
1/2"	TA25B-12-N	25	825	1070			
	TS25B-12-N						
	TA125-12-N	125	825	1070	1323	1610	1950
	TS125-12-N						
3/4"	TA25B-13-N	25	1290	1700			
	TS25B-13-N						
	TA125-13-N	125	1290	1700	2100	2575	3300
	TS125-13-N						

MATERIALS

Body	Forged Brass, CA 377
Element	Welded Stainless Steel, AISI 302
Cover	Forged Brass, CA 377
Spring	Stainless Steel, AISI 304
Seat	TA25B/TS25B: Brass ASTM B-21 TA125/TS125: Stainless Steel, AISI 303
Gasket	Brass, ASTM B-21
Union Nipple	Brass, ASTM B-16
Union Nut	Brass, ASTM B-16

(Repairable)



Model	WT2500 (Repairable)
Sizes	1/2", 3/4"
Connections	NPT
Body Material	Cast Iron
PMO Max. Operating Pressure	250 PSIG
TMO Max. Operating Temperature	406°F
PMA Max. Allowable Pressure	250 PSIG up to 450°F
TMA Max. Allowable Temperature	450°F @ 250 PSIG

Typical Applications

DRIP, TRACING, PROCESS: The **WT2500** is a general purpose medium capacity thermostatic trap that can be used for steam tracing; as a drip trap on steam mains and steam supply lines; as well as for process applications. All internal working components can be replaced while the trap body remains in-line. Like all thermostatic traps, they are small, light weight, operate over a wide pressure range, and have excellent air handling capabilities. Discharging air at start-up allows steam to quickly enter the system. The WT2500 is an excellent choice for a variety of applications. Contains an extremely strong and rugged precision welded Stainless Steel thermal element which is highly resistant to waterhammer.

How It Works

The thermostatic trap contains a welded stainless steel thermal element that expands when heated and contracts when cooled. When air and condensate are present, the trap is in the open discharge position. When steam reaches the trap, the element expands and closes off tightly.

Features

- The thermal element and seat can be easily removed and replaced in minutes with the trap body still in-line
- Operates at steam pressures up to 250 PSIG
- Thermostatic traps have excellent air handling capability
- Welded stainless steel thermal element resists shock from water hammer
- Freeze-proof when trap is installed in a vertical orientation allowing for complete condensate drainage
- Hardened stainless steel seat for extended service life

MATERIALS

Cover & Body	Cast Iron ASTM A-126 Class B
Thermal Element	Stainless Steel, AISI 302
Valve & Seat	Stainless Steel, AISI 416
Cover Gasket	Garlock

CAPACITIES — condensate (lbs/hr)

Size	Model Code	Orifice Size	Steam Inlet Pressure (PSIG)								
			5	10	20	50	100	125	150	200	250
1/2"	WT2501-12-N	3/16"	441	625	882	1391	1827	1969	2095	2305	2483
3/4"	WT2501-13-N		903	1271	1811	2861	3754	4043	4300	4730	5093
1/2"	WT2503-12-N	5/16"	903	1271	1811	2861	3754	4043	4300	4730	5093
3/4"	WT2503-13-N		903	1271	1811	2861	3754	4043	4300	4730	5093

Sample Specification

The steam trap shall be of a thermostatic type with cast iron body and stainless steel thermal element. Trap must be in-line repairable with a bolt-on type cover that is sealed with a spiral wound Stainless Steel AISI 316 gasket. Valve and seat to be hardened stainless steel.

Installation and Maintenance

Trap can be installed in any orientation. All internal working components are extremely easy to replace and can be performed while the trap body remains in line by removing the four-bolt cover. Repair kit includes ALL parts to fully rebuild the steam trap including thermal element, seat and gasket.

Helpful Selection Information

Two orifice sizes are available: The 3/16" orifice should be used on all drip and tracing applications as well as small process applications with lower condensate loads. The 5/16" orifice is available to be used on process applications if additional capacity is required.

Options

SLR = Steam lock release

How to Size / Order

Select working pressure; follow column down to correct capacity (lbs/hr). Example:

Application: 1827 lbs/hr at 100 PSIG working inlet pressure
 Size/Model: **WT2501-12-N**, 1/2" NPT, 3/16" orifice.

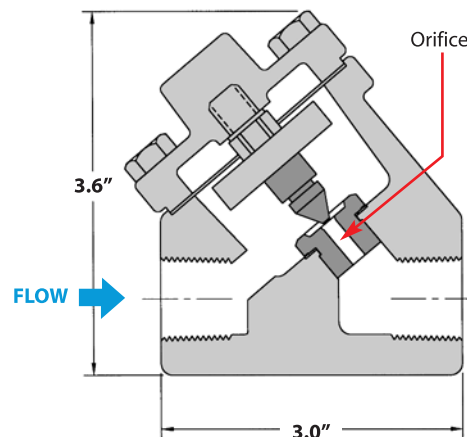







Float & Thermostatic

64-83

Model	Body Material	PMO (PSIG)	Sizes	Connections	Page No.
WFT	Cast Iron	250	3/4" – 2"	NPT	66
FTT	Ductile Iron	300	1/2" – 2"	NPT	70
FTE/FTES	Ductile Iron/Cast Steel	200/300	1 1/2", 2", 2 1/2"	NPT, SW, FLG	74
FT600/FT601	Carbon Steel/Stainless Steel	450	3/4" – 4"	NPT, SW, FLG	76
FT	Cast Iron	75	3/4" – 2"	NPT	82

PMO = Maximum Operating Pressure

	Characteristics	Material	Application
<p>WFT</p> 	Parallel Pipe Connection	Cast Iron	Primary Selection for Low to Medium Capacity General Purpose Process Applications Smaller sizes can also be used for Drip Applications
<p>FTT</p> 	In-Line Pipe Connection	Ductile Iron	
<p>FTE & FTES</p> 	Extremely High-Capacity	FTE: Ductile Iron FTES: Cast Steel	High Capacity Process Applications
<p>FT600 & FT601</p> 	Cast Steel Body	FT600: Carbon Steel FT601: Stainless Steel	Where Carbon Steel or Stainless Steel bodies are required
<p>FT</p> 	Parallel Pipe Connection (H-pattern)	Cast Iron	General Purpose, Low to Medium Capacity Process Applications up to 75 psig Smaller sizes can also be used for Drip Applications

Introduction

FLOAT & THERMOSTATIC TRAPS

F&T steam traps are the most common trap type used for process applications. They use a float-operated valve mechanism to discharge condensate as it is formed, and an air vent for discharging air at start-up; both very important requirements for process applications. The WFT and FTT-Series with Iron bodies, are suitable for most general purpose process applications up to 250 PSIG. The 3/4" WFT and FTT are often used for drip applications. The FTE-Series has extremely high capacity. The FT600 Series available with Cast Steel or Stainless Steel bodies; often required in Chemical and Petrochemical refineries and other industries.

F&T Traps are classified as mechanical style traps and require the buoyancy of the float, and a lever mechanism to lift the valve disc off the seat orifice. Larger seat orifices and higher steam pressures require additional buoyancy and mechanical force for the trap to open. Select a trap model with an equal or higher PMO rating than the steam pressure, or the trap will not open. F&T traps are not self-draining and are therefore subject to freezing in cold climates. Freeze protection valves are available to fully drain most model F&T traps during shut down periods.

Operation:

At start-up, air and condensate enter the steam trap. The air will be discharged through the open thermostatic air vent (**Figure A**). As the condensate level in the trap rises, it lifts the float which opens the valve to allow the discharge of condensate. When steam enters the trap, the thermostatic element expands and closes the air vent, preventing the steam from escaping (**Figure B**). As the condensate discharges through the seat orifice, the float lowers, and shuts the valve (**Figure C**). The float level rises and falls to modulate the seat opening in order to maintain a constant equilibrium between the incoming and discharging condensate. Due to the balance of forces required between the incoming pressure and internal trap components, several orifice sizes are offered to accommodate various differential pressure ranges. These traps can be fitted with a steam lock release (SLR) to be used when the steam trap is physically positioned above the condensate collection point. For superheated steam applications, the thermostatic air vent is replaced with a live orifice air vent.

A) Venting Air

Thermostatic Air Vent (Open) when Air is present

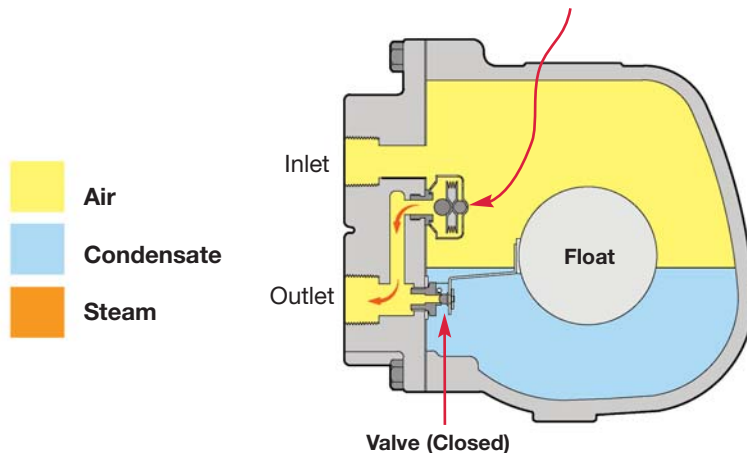

A) When cold air enters the trap during start-up, the thermostatic air vent is open, allowing the discharge of large quantities of air from the system.

B) When condensate enters the trap, the float lifts which opens the valve, allowing condensate to discharge.

C) When steam is present, and no condensate is entering the trap, the valve and thermostatic air vent remain closed, trapping steam in the system.

B) Discharging Condensate

Thermostatic Air Vent (Closed) when Steam is present

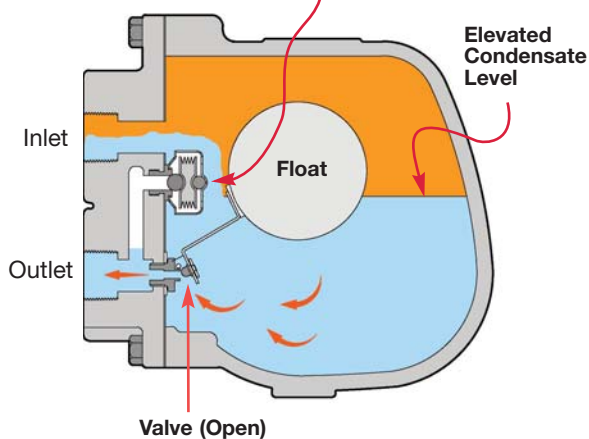

C) Closed (Trapping Steam)

Thermostatic Air Vent (Closed) when Steam is present

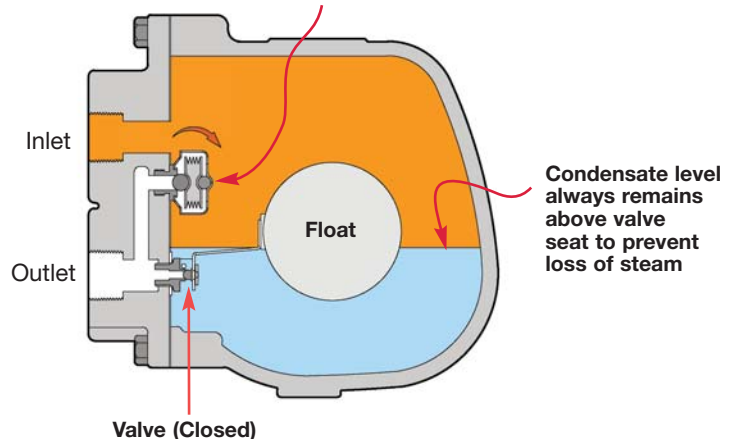

Steam Traps

Float & Thermostatic Steam Trap

WFT Series

Float & Thermostatic

Model	WFT
Sizes	3/4", 1", 1 1/4", 1 1/2", 2"
Connections	NPT
Body Material	Cast Iron
PMO Max. Operating Pressure	250 PSIG
TMO Max. Operating Temperature	Saturated Steam Temperature
PMA Max. Allowable Pressure	250 PSIG up to 450°F
TMA Max. Allowable Temperature	450°F @ 250 PSIG



Typical Applications

PROCESS, DRIP: WFT Series with parallel port connections were specifically designed for removing condensate and air from HVAC and industrial process applications such as unit heaters, pressing machines, heat exchangers and coils. They contain a high-quality welded stainless steel thermostatic air vent and stainless steel mechanism. The WFT Series are fully repairable while the trap remains in-line and are available in 3/4" thru 2" NPT connections. For drip applications, such as draining steam mains and steam supply lines, use model 3/4" WFT-125 (WFT-125-13-N).

How It Works

Float and thermostatic traps contain a float-operated valve and seat mechanism with a separate thermostatic element which work together to remove both condensate and air from the steam system. The float, which is attached to a valve, rises and opens the valve when condensate enters the trap, allowing the condensate to discharge. Air is discharged through the thermostatic air vent to the outlet side of the trap. Steam entering the trap causes the thermostatic element to expand, closing the air vent and trapping the steam.

Features

- All stainless steel internals with hardened seat and wear parts
- In-line repairability is simplified by having all internals attached to the cover
- Welded stainless steel thermostatic air vent resists shock from waterhammer. Live orifice air vent is available for superheated applications
- Excellent air handling capability allows air to be discharged rapidly so steam can enter the system quickly during start-up
- F&T traps discharge condensate immediately as it is formed (no condensate will back up into the system)

Sample Specification

The trap shall be of float and thermostatic design with cast iron body and parallel piping configuration. Thermostatic air vent to be welded stainless steel. All internals must be stainless steel with hardened seat area. Trap must be in-line repairable.

Installation and Maintenance

The trap must be installed upright and level for the float mechanism to operate properly. All internal components can be replaced with the trap connected in-line. Repair kits include thermostatic air vent, float, valve seat and disc, and gaskets. The standard thermostatic air vent can be damaged by superheat; therefore, in applications with superheated steam, the thermostatic air vent should be replaced with a special "live orifice" air vent.

Options

- Live orifice air vent for superheated steam applications.
- NPT Connection for freeze protection

MATERIALS

Body & Cover	Cast Iron
Gasket	Grafoil
Cover Screws	Steel, GR5
Float	Stainless Steel, AISI 304
Internals	Stainless Steel, 300 Series
Thermostat	Stainless Steel
Valve Seat	Stainless Steel, 17-4 PH
Valve Disc	Stainless Steel, AISI 420F

Demonstration of Parallel piping connections:

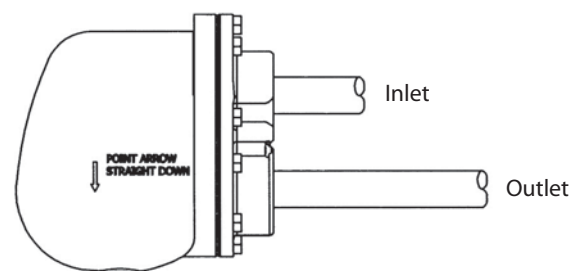

How to Size / Order

The PMO (maximum operating pressure) rating of model selected must meet or exceed the maximum steam pressure or the trap may not open. For example; the WFT-125 has a PMO of 125 psi. Condensate capacity (lbs/hr) of the trap is based on the differential pressure across the trap. For drip applications, a 3/4" WFT size is generally sufficient to exceed warm-up loads with a 2X safety factor. The condensate loads (lbs/hr) for process applications are normally calculated at the maximum steam pressure; then an appropriate safety margin is applied in order to select a trap with sufficient capacity when operating at lower steam pressures. Reference full explanation of Safety Load Factors in Steam Trap Introduction section.

When a temperature control valve regulates the flow of steam to the process equipment (Heat Exchanger) being drained of condensate, it is recommended to select a trap with a PMO that exceeds the inlet steam pressure to the temperature control valve. This assures that under all operating conditions, the steam pressure will not exceed the PMO of the trap.

For Example: Process application has a maximum steam inlet pressure of 100 psi, a maximum condensate load of 2,500 lbs/hr and is discharging to a condensate return line with a possible back pressure of 25 PSIG. $\Delta P = 100 - 25 = 75$ PSI

To select trap: If the Safety Load Factor is chosen to be 2X max capacity at max differential pressure, then Trap should be selected based on 5,000 lbs/hr ($2,500 \times 2 = 5,000$) at 75 PSI differential pressure with a PMO in excess of 100 PSIG

Selection: WFT-125-17-N, PMO=125 PSIG, 2" NPT with a condensate capacity of 7,460 lbs/hr at 75 PSI differential pressure.

CAPACITIES – Condensate (lbs/hr)

Model Code	PMO (PSIG)	Pipe Size	Orifice Size	$\Delta P =$ Differential Pressure (PSI)																		
				1/4	1/2	1	2	5	10	15	20	30	40	50	75	100	125	150	175	200	225	250
WFT-015-13-N	15	3/4"	0.250	390	490	620	780	1050	1320	1500												
WFT-015-14-N	15	1"	0.250	390	490	620	780	1050	1320	1500												
WFT-015-15-N	15	1 1/4"	0.312	610	770	960	1210	1630	2040	2330												
WFT-015-16-N	15	1 1/2"	0.500	1420	1910	2570	3460	5120	6890	8190												
WFT-015-17-N	15	2"	0.625	2260	2950	3860	5040	7170	9360	10930												
WFT-030-13-N	30	3/4"	0.228	330	420	530	670	930	1180	1350	1500	1720										
WFT-030-14-N	30	1"	0.228	330	420	530	670	930	1180	1350	1500	1720										
WFT-030-15-N	30	1 1/4"	0.228	330	420	530	670	930	1180	1350	1500	1720										
WFT-030-16-N	30	1 1/2"	0.390	930	1240	1650	2190	3210	4280	5060	5700	6750										
WFT-030-17-N	30	2"	0.500	1420	1910	2570	3460	5120	6890	8190	9260	11020										
WFT-075-13-N	75	3/4"	0.166	175	225	295	385	545	705	825	920	1075	1200	1305	1525							
WFT-075-14-N	75	1"	0.166	175	225	295	385	545	705	825	920	1075	1200	1305	1525							
WFT-075-15-N	75	1 1/4"	0.312	640	850	1130	1500	2180	2900	3420	3850	4540	5110	5600	6610							
WFT-075-16-N	75	1 1/2"	0.312	640	850	1130	1500	2180	2900	3420	3850	4540	5110	5600	6610							
WFT-075-17-N	75	2"	0.422	1020	1340	1760	2310	3330	4380	5140	5760	6770	7590	8290	9730							
WFT-125-13-N	125	3/4"	0.128	105	135	180	235	340	445	525	585	690	770	845	990	1110	1210					
WFT-125-14-N	125	1"	0.128	105	135	180	235	340	445	525	585	690	770	845	990	1110	1210					
WFT-125-15-N	125	1 1/4"	0.250	410	540	710	930	1340	1770	2070	2320	2730	3050	3340	3920	4390	4790					
WFT-125-16-N	125	1 1/2"	0.250	410	540	710	930	1340	1770	2070	2320	2730	3050	3340	3920	4390	4790					
WFT-125-17-N	125	2"	0.332	720	960	1270	1690	2460	3270	3860	4340	5130	5770	6320	7460	8390	9190					
WFT-175-13-N	175	3/4"	0.166	190	250	320	420	590	770	900	1010	1180	1310	1430	1670	1870	2030	2180	2310			
WFT-175-14-N	175	1"	0.166	190	250	320	420	590	770	900	1010	1180	1310	1430	1670	1870	2030	2180	2310			
WFT-175-15-N	175	1 1/4"	0.250	410	540	710	930	1340	1770	2070	2320	2730	3050	3340	3920	4390	4790	5150	5470			
WFT-175-16-N	175	1 1/2"	0.250	410	540	710	930	1340	1770	2070	2320	2730	3050	3340	3920	4390	4790	5150	5470			
WFT-175-17-N	175	2"	0.281	520	680	900	1180	1700	2230	2620	2930	3440	3860	4210	4950	5540	6050	6510	6920			
WFT-250-13-N	250	3/4"	0.128	115	145	190	245	345	450	520	580	675	755	820	955	1060	1155	1235	1310	1375	1440	1495
WFT-250-14-N	250	1"	0.128	115	145	190	245	345	450	520	580	675	755	820	955	1060	1155	1235	1310	1375	1440	1495
WFT-250-15-N	250	1 1/4"	0.203	270	350	450	590	820	1070	1240	1380	1600	1780	1940	2250	2500	2720	2910	3080	3240	3380	3520
WFT-250-16-N	250	1 1/2"	0.203	270	350	450	590	820	1070	1240	1380	1600	1780	1940	2250	2500	2720	2910	3080	3240	3380	3520
WFT-250-17-N	250	2"	0.250	410	540	710	930	1340	1760	2060	2310	2710	3040	3320	3890	4360	4760	5110	5430	5730	6000	6250

Steam Traps

Float & Thermostatic Steam Trap

WFT Series

Float & Thermostatic

Dimensions: inches



WFT
3/4" • 1" • 1 1/4"

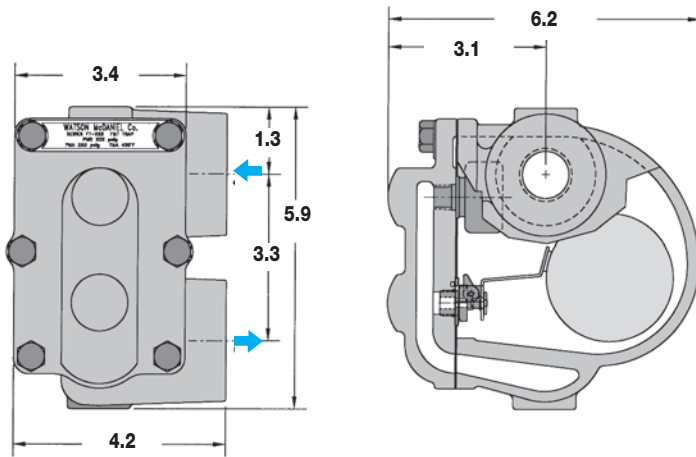

SPECIFICATIONS

Model	Sizes	Connection	PMO (PSIG)	PMA (PSIG)	Weight (lbs)
WFT-15	3/4", 1", 1 1/4"	NPT	15	125	9
WFT-30	3/4", 1", 1 1/4"	NPT	30	125	9
WFT-75	3/4", 1"	NPT	75	125	9
WFT-125	3/4", 1"	NPT	125	125	9



WFT
3/4" & 1"

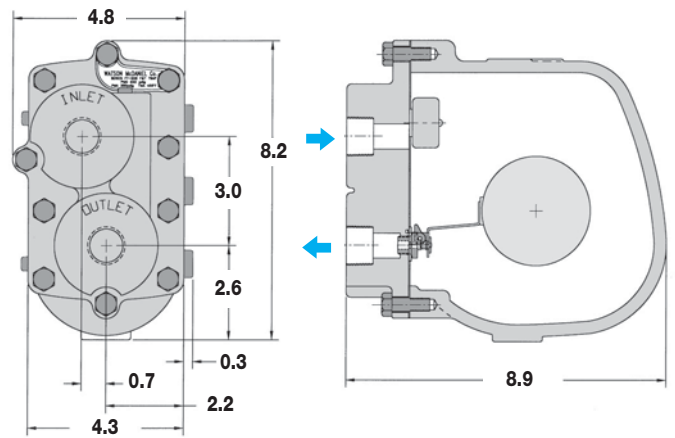

SPECIFICATIONS

Model	Sizes	Connection	PMO (PSIG)	PMA (PSIG)	Weight (lbs)
WFT-175	3/4", 1"	NPT	175	250	20
WFT-250	3/4", 1"	NPT	250	250	20

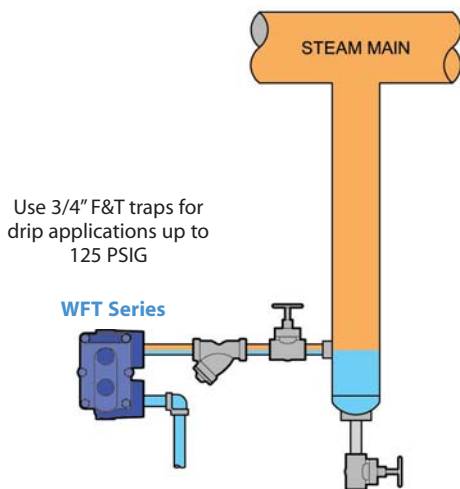

Steam Main Drip Application

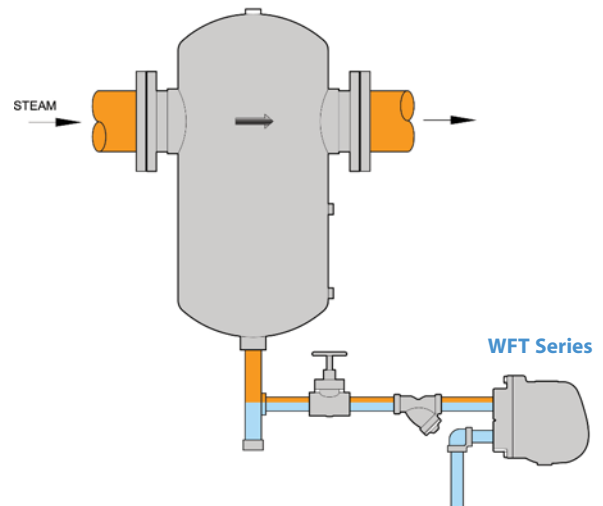

Separator Application

Steam Traps

Float & Thermostatic Steam Trap

WFT Series

Float & Thermostatic

Dimensions: inches



WFT
1 1/4" & 1 1/2"



WFT
2"

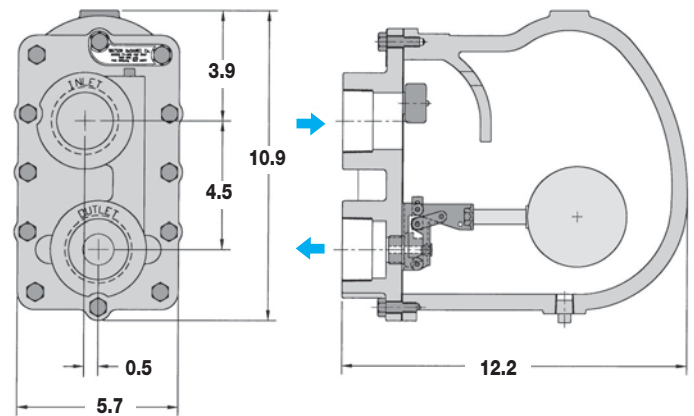
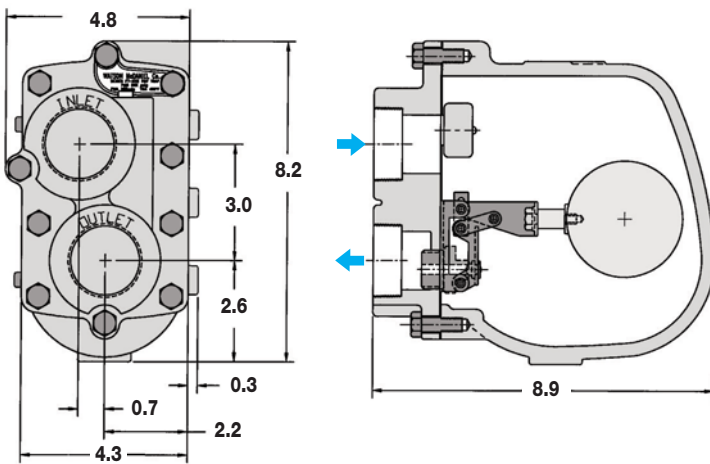

SPECIFICATIONS					
Model	Sizes	Connection	PMO (PSIG)	PMA (PSIG)	Weight (lbs)
WFT-15	1 1/2"	NPT	15	250	21
WFT-30	1 1/2"	NPT	30	250	21
WFT-75	1 1/4", 1 1/2"	NPT	75	250	21
WFT-125	1 1/4", 1 1/2"	NPT	125	250	21
WFT-175	1 1/4", 1 1/2"	NPT	175	250	21
WFT-250	1 1/4", 1 1/2"	NPT	250	250	21

SPECIFICATIONS					
Model	Sizes	Connection	PMO (PSIG)	PMA (PSIG)	Weight (lbs)
WFT-15	2"	NPT	15	250	53
WFT-30	2"	NPT	30	250	53
WFT-75	2"	NPT	75	250	53
WFT-125	2"	NPT	125	250	53
WFT-175	2"	NPT	175	250	53
WFT-250	2"	NPT	250	250	53

Multi-bank Air Heating Coils / Air Handler Unit

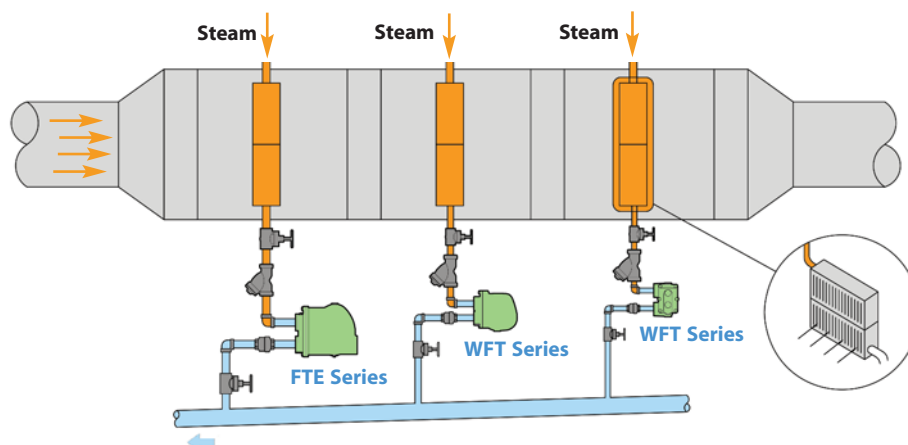

Steam Traps

Float & Thermostatic Steam Trap

FTT Series
Float & Thermostatic

Model	FTT
Sizes	1/2", 3/4", 1", 1 1/2", 2"
Connections	NPT, 150# FLG (1" - 2")
Body Material	Ductile Iron
PMO Max. Operating Pressure	300 PSIG
TMO Max. Operating Temperature	Saturated Steam Temperature
PMA Max. Allowable Pressure	300 PSIG up to 450°F
TMA Max. Allowable Temperature	450°F @ 300 PSIG

1/2" & 3/4" available in NPT only.

Typical Applications

DRIP, PROCESS: FTT Series steam traps with in-line pipe connections are used for the removal of condensate and air in HVAC and industrial process applications such as unit heaters, water heaters, pressing machines, heat exchangers and coils. They contain a high-quality welded stainless steel thermostatic air vent and stainless seat and mechanism. F&T traps have excellent air handling capability, making them a better choice than Inverted Bucket traps for most process applications. For drip applications, such as draining steam mains and steam supply lines, use 1/2" or 3/4" sizes.

How It Works

Float and thermostatic traps contain a float and seat mechanism with a separate thermostatic element which work together to remove both condensate and air from the steam system. The float, which is attached to a valve, rises and opens the valve when condensate enters the trap. This allows the condensate to discharge. Air is discharged through the thermostatic air vent to the outlet side of the trap. Steam entering the trap causes the thermostatic element to expand, closing the air vent and trapping the steam.

Sample Specification

The trap shall be of float and thermostatic design with ductile iron body and in-line piping configuration. Thermostatic air vent to be welded stainless steel. All internals must be stainless steel with hardened seat area. Trap must be in-line repairable.

Options

- Live orifice air vent for superheated steam applications.
- NPT Connection for freeze protection

How to Size / Order

The PMO (maximum operating pressure) rating of model selected must meet or exceed the maximum steam pressure or the trap may not open. For example; the FTT-145 has a PMO of 145 psi. Condensate capacity (lbs/hr) of the trap is based on the differential pressure across the trap. For drip applications, a 1/2" FTT size is generally sufficient to exceed warm-up loads with a 2X safety factor. The condensate loads (lbs/hr) for process applications are normally calculated at the maximum steam pressure; then an appropriate safety margin is applied in order to select the trap with sufficient capacity when operating at lower steam pressures. Reference full explanation of Safety Load Factors in Steam Traps Introduction section.

When a temperature control valve is regulating flow to the process equipment, it is recommended to select a trap with a PMO that will exceed the inlet steam pressure to the control valve.

For Example: Process application has a maximum steam inlet pressure of 100 psi, a maximum condensate load of 2,500 lbs/hr and is discharging to a condensate return line with a possible back pressure of 25 psig. $\Delta P = 100 - 25 = 75$ PSI

To select trap: If the Safety Load Factor is chosen to be 2X max capacity at max differential pressure, then Trap should be selected based on 5,000 lbs/hr (2,500 x 2 = 5,000) at 75 PSI differential pressure with a PMO in excess of 100 PSIG

Selection: FTT-145-16-N, PMO=145 PSIG, 1 1/2" NPT with a condensate capacity of 9,600 lbs/hr at 75 PSI differential pressure.

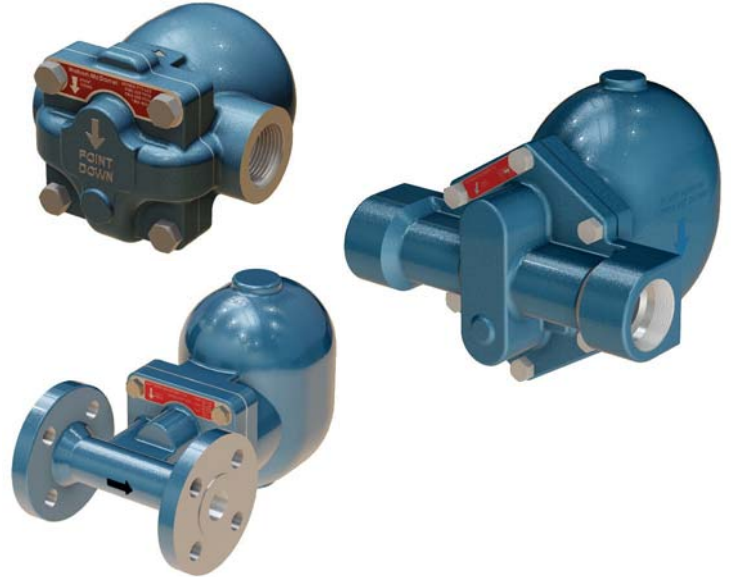

Installation and Maintenance

The trap must be installed upright and level for the float mechanism to operate properly. All internal components can be replaced with the trap body remaining in-line. Repair kits include thermostatic air vent, float, valve seat and disc, and gaskets. The standard thermostatic air vent can be damaged by superheat; therefore, in applications with superheated steam, the thermostatic air vent should be replaced with a special "live orifice" air vent.

Features

- Ductile Iron has a higher pressure and temperature rating and is more resistant to shock loads than cast Iron
- All stainless steel internals with hardened seat and wear parts
- In-line repairability is simplified by having all internals attached to the cover
- Welded stainless steel thermostatic air vent resists shock from waterhammer. Live orifice air vent is available for superheated applications
- Excellent air handling capability allows air to be discharged rapidly so steam can enter the system quickly during start-up
- F&T traps discharge condensate immediately as it is formed (no condensate will back up into the system)

Steam Traps

Float & Thermostatic Steam Trap

FTT Series

Float & Thermostatic

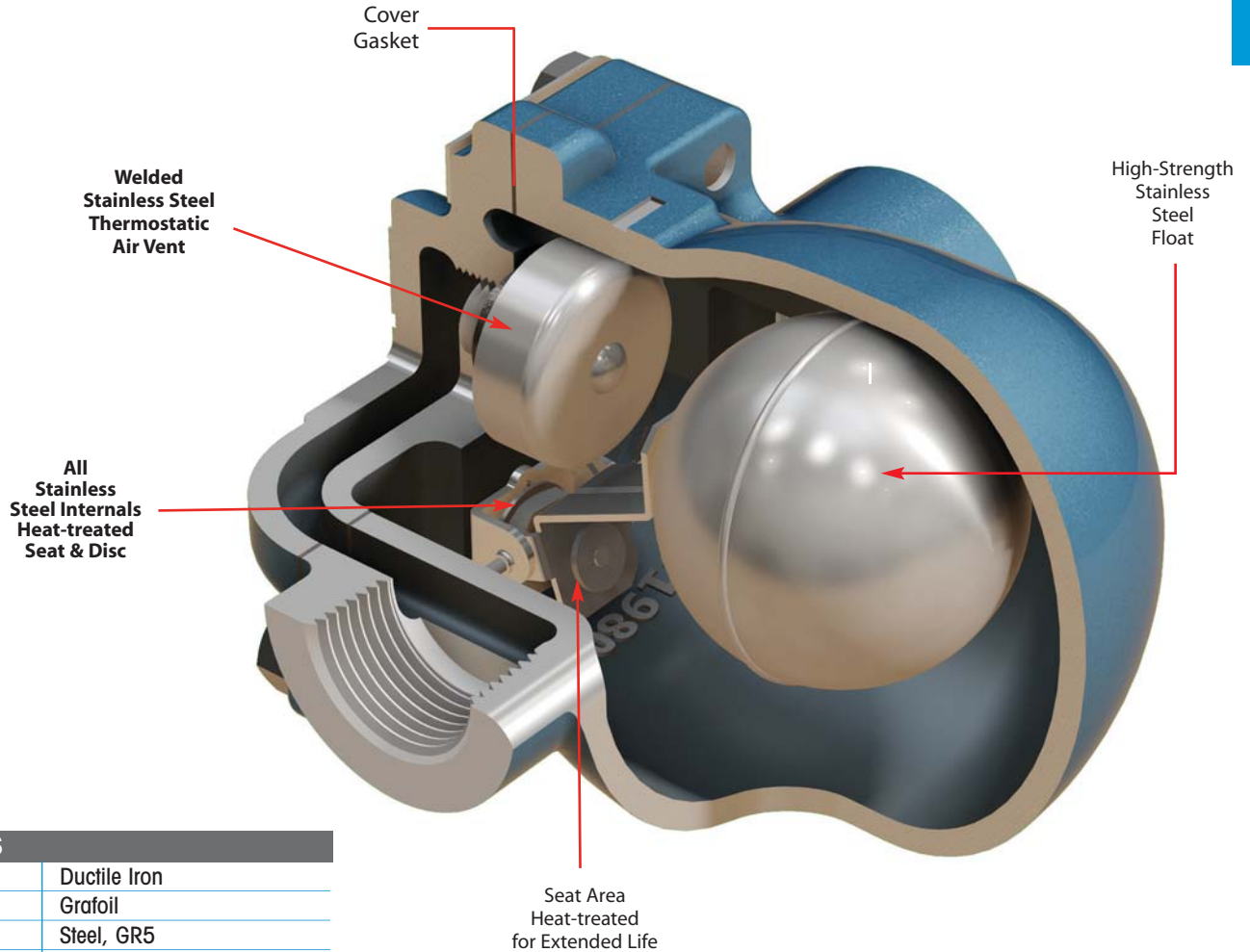

MATERIALS

Body & Cover	Ductile Iron
Gasket	Grafoil
Cover Screws	Steel, GR5
Float	Stainless Steel, AISI 304
Internals	Stainless Steel
Thermostat	Stainless Steel
Valve Seat	Stainless Steel, 17-4 PH
Valve Disc	Stainless Steel, AISI 420F

Connection Code: **N**=NPT **F150** = 150# FLG
 1/2" & 3/4" available in NPT only.
PMO = Max Operating Pressure

CAPACITIES – Condensate (lbs/hr)

Model Code	PMO (PSIG)	Pipe Size	ΔP = Differential Pressure (PSI)																				
			1/4	1/2	1	2	5	10	15	20	30	40	50	65	75	100	125	145	200	225	250	300	
FTT-065-12-N	65	1/2"	115	155	205	270	390	520	610	685	810	910	995	1110									
FTT-065-13-N	65	3/4"	115	155	205	270	390	520	610	685	810	910	995	1110									
FTT-065-14-N	65	1"	340	500	775	1100	1700	2400	2800	3250	3925	4200	5000	5825									
FTT-065-16-N	65	1 1/2"	1150	1650	2500	3450	5300	7500	8180	10600	13100	15000	16800	18900									
FTT-065-17-N	65	2"	3470	4820	8500	11950	18700	25200	26900	36000	43000	49600	55500	61300									
FTT-145-12-N	145	1/2"	55	75	100	135	200	270	320	365	435	490	540	600	640	725	795	850					
FTT-145-13-N	145	3/4"	55	75	100	135	200	270	320	365	435	490	540	600	640	725	795	850					
FTT-145-14-N	145	1"	190	275	405	550	840	1200	1380	1600	1850	2200	2450	2750	2920	3400	3700	3900					
FTT-145-16-N	145	1 1/2"	685	970	1275	1750	2740	3750	4490	5100	6250	7200	8000	8900	9600	11250	12000	13300					
FTT-145-17-N	145	2"	1860	2680	3125	4400	6900	9250	13790	14600	16900	19400	21900	25000	26800	31000	34000	37000					
FTT-225-12-N	225	1/2"	40	50	70	95	135	185	220	245	290	330	360	405	430	485	530	565	645	680			
FTT-225-13-N	225	3/4"	40	50	70	95	135	185	220	245	290	330	360	405	430	485	530	565	645	680			
FTT-225-14-N	225	1"	150	200	300	405	600	820	975	1130	1375	1510	1620	1875	2000	2350	2600	2750	3100	3250			
FTT-250-16-N	250	1 1/2"	530	710	825	1130	1760	2500	2950	3375	4125	4740	5250	6000	6400	7300	8000	8650	10200	10800	11300		
FTT-250-17-N	250	2"	695	985	1560	2185	3490	4800	5800	6750	8250	9500	10650	12400	13300	15000	16600	18120	21200	22300	23200		
FTT-300-14-N	300	1"	100	155	220	300	460	630	750	860	1060	1240	1360	1450	1600	1820	2000	2130	2500	2650	2800	3000	

Steam Traps

Float & Thermostatic Steam Trap

FTT Series

Float & Thermostatic

Dimensions: inches

FTT • 1/2" & 3/4"

Weight: 6 lbs.

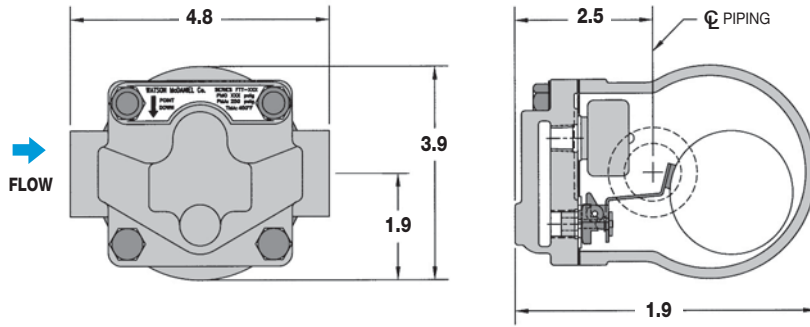

FTT 1" Weight threaded NPT: 16 lbs.

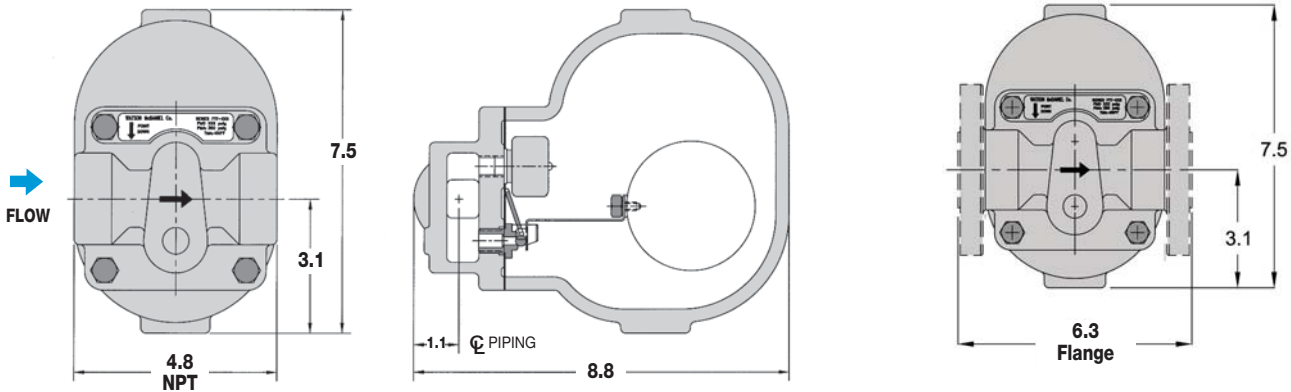

FTT • 1 1/2" • Weight threaded NPT 38 lbs.

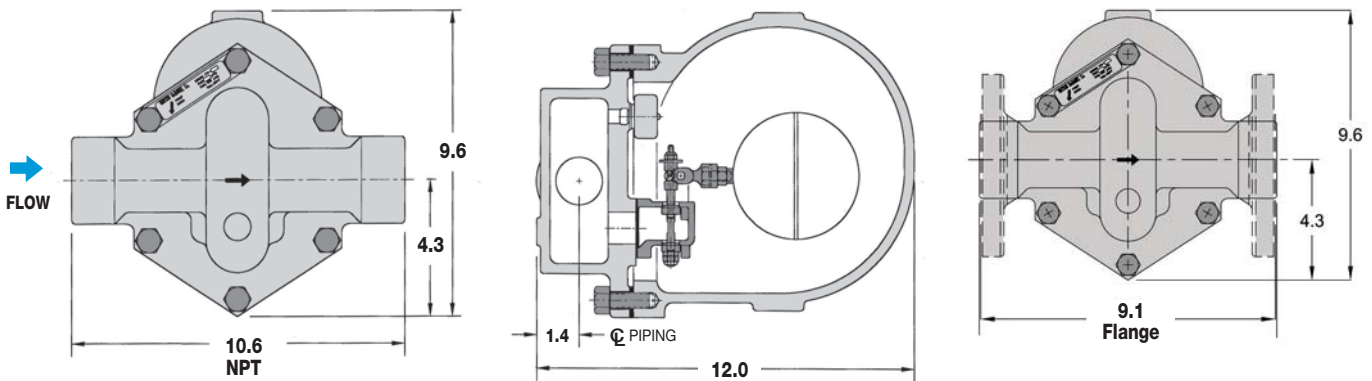

FTT • 2" • Weight threaded NPT 42 lbs.

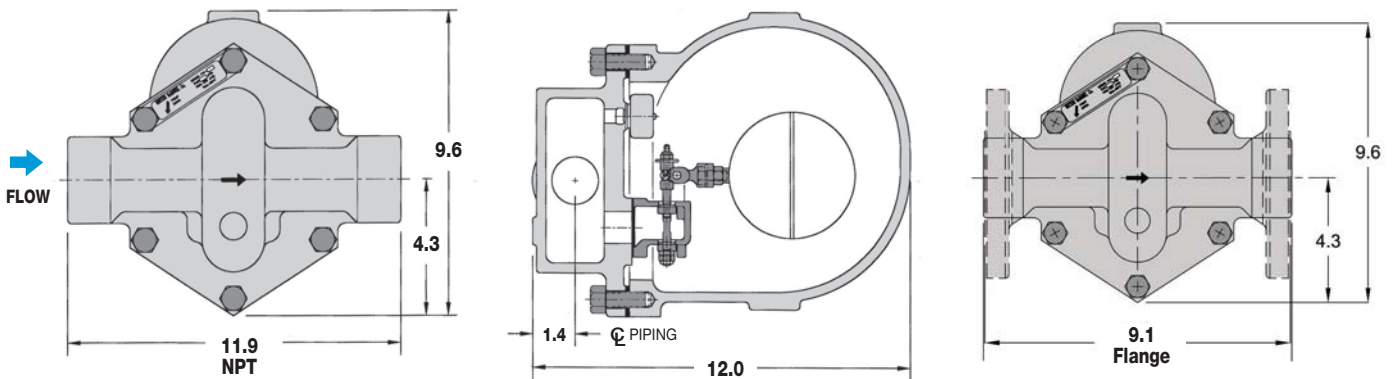

Typical Applications for Float & Thermostatic Steam Traps

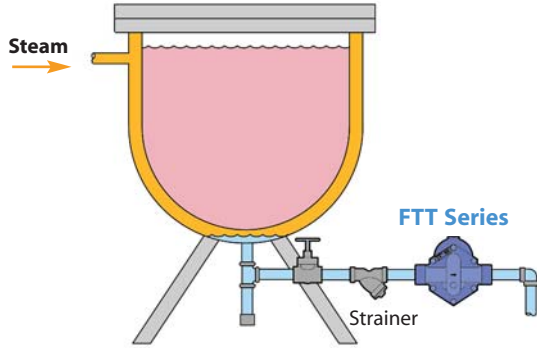

Jacketed Kettle Application

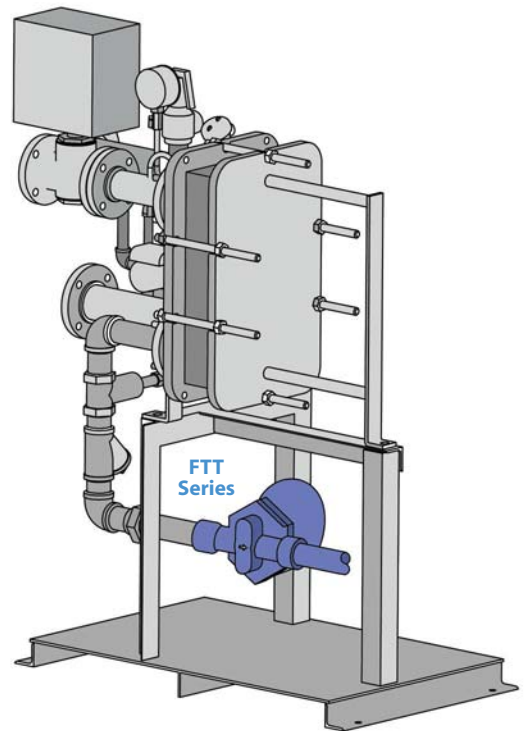

Instantaneous Steam to Hot Water Heater (Heat Miser)

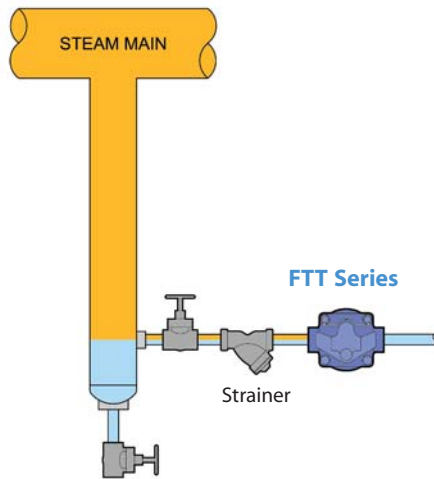

Steam Main Drip Application

Steam Traps

Float & Thermostatic Steam Trap

FTE & FTES
Float & Thermostatic

Model	FTE	FTES
Sizes	1 1/2", 2", 2 1/2"	2 1/2"
Connections	NPT	NPT, SW, FLG
Body Material	Ductile Iron	Cast Steel
PMO Max. Operating Pressure	200 PSIG	300 PSIG
TMO Max. Operating Temperature	450°F	450°F
PMA Max. Allowable Pressure	300 PSIG up to 450°F	300 PSIG up to 750°F
TMA Max. Allowable Temperature	450°F @ 300 PSIG	750°F @ 300 PSIG

The FTE & FTES are used for extremely high capacity condensate drainage applications.

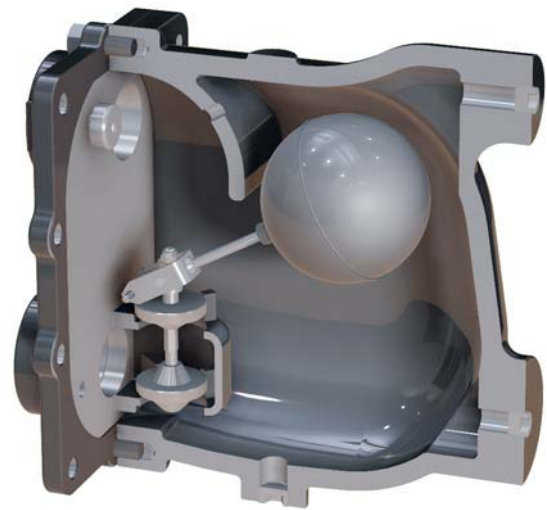

Typical Applications

PROCESS: FTE & FTES Series are high capacity steam traps specifically designed to remove condensate and air from HVAC and industrial process applications with extremely high condensate load requirements. Examples include reboilers, absorption chillers, large air-handling coils, large heat exchangers and other large process equipment. They are available with a ductile iron (FTE) or steel body (FTES) and contain a high quality welded stainless steel thermostatic air vent and stainless mechanism. F&T traps have excellent air-handling capability, making them a better choice than Inverted Bucket traps for most process applications.

Features

- Ductile Iron has a higher pressure and temperature rating and is more resistant to shock loads than Cast Iron
- Cast Steel Body will allow operating pressures and temperatures up to 300 PSIG and 450°F
- High capacity steam trap for draining large process equipment (over 100,000 lbs/hr)
- All stainless steel internals with hardened seat and wear parts
- In-line repairability is simplified by having all internals attached to the cover
- Welded stainless steel thermostatic air vent resists shock from waterhammer. Live orifice air vent is available for superheated applications
- Excellent air handling capability allows air to be discharged rapidly so steam can enter the system quickly during start-up
- F&T traps discharge condensate immediately as it is formed (no condensate will back up into the system)

How It Works

Float and thermostatic traps contain a float and seat mechanism with a separate thermostatic element which work together to remove both condensate and air from the steam system. The float, which is attached to a valve, rises and opens the valve when condensate enters the trap. This allows the condensate to discharge. Air is discharged through the thermostatic air vent to the outlet side of the trap. Steam entering the trap causes the thermostatic element to expand, closing the air vent and trapping the steam.

Sample Specification

The trap shall be of float and thermostatic design with ductile iron or cast steel body. The trap must incorporate all stainless steel internals with hardened seat and welded stainless steel thermostatic air vent. Trap must be in-line repairable.

Installation and Maintenance

The trap must be installed upright and level for the float mechanism to operate properly. All internal components can be replaced with the trap body remaining in-line. Repair kits include thermostatic air vent, float, valve seat and disc, and gaskets. The FTES Series have cast steel bodies and are available in 2 1/2" NPT, socket weld and flange connections. The standard thermostatic air vent can be damaged by superheat; therefore, in applications with superheated steam, the thermostatic air vent should be replaced with a special "live orifice" air vent.

Options

Live orifice air vent for superheated steam applications.

Parallel-pipe inlet/outlet connections are standard as shown. An optional In-line inlet/outlet connection is available; contact factory.

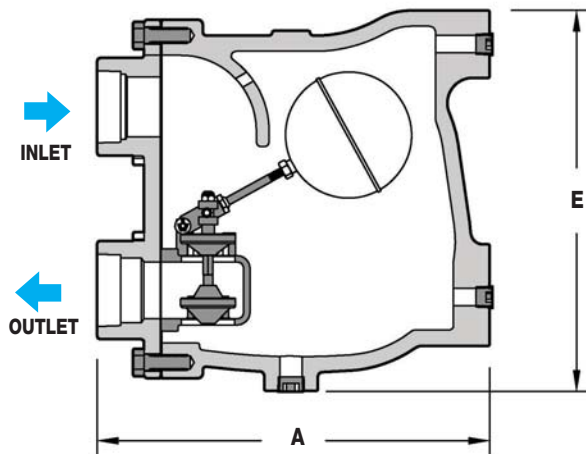
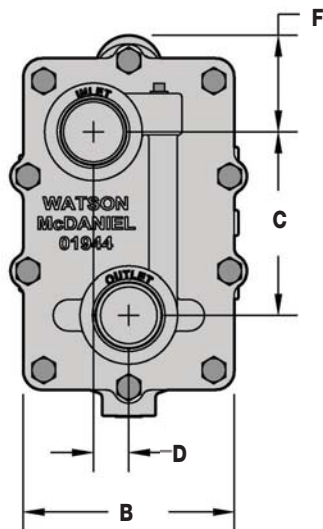

DIMENSIONS & WEIGHTS – inches							
Size/Model	A	B	C	D	E	F	Weight
2" FTE-20	12.6	5.7	4.5	0.5	11.1	3.9	54
2" FTE-50	16.0	8.4	7.3	1.4	15.6	3.6	150
2 1/2" FTE-50	15.5	8.4	7.3	1.4	15.6	3.6	150
2 1/2" FTE-125	15.5	8.4	7.3	1.4	15.6	3.6	150
1 1/2" FTE-200	9.6	4.3	3.0	0.7	8.8	2.6	35
2" FTE-200	12.6	5.7	4.5	0.5	11.1	3.9	65
2 1/2" FTE-200	15.5	8.4	7.3	1.4	15.6	3.6	150
2 1/2" FTES-300	15.5	8.4	7.3	1.4	15.6	3.6	150

MATERIALS	
Body & Cover (FTE)	Ductile Iron
Body & Cover (FTES)	Cast Steel, ASTM A-216
Cover Screw	Grade 5 Carbon Steel
Cover Gasket	Grafoil
Valve Discs	Stainless Steel, AISI 17-4PH
Main Valve Assembly Housing	Stainless Steel, AISI 17-4PH
Valve Assembly Gasket	Garlock
Ball Float	Stainless Steel, AISI 304
Thermostatic Vent	Stainless Steel, AISI 300 Optional: Live orifice air vent

Note: 2 1/2" FTES-50, 125 & 300 have same dimensions and weights.

How to Size / Order

The PMO (maximum operating pressure) rating of model selected must meet or exceed the maximum steam pressure or the trap may not open. For example; the FTE-125 has a PMO of 125 psi. Condensate capacity (lbs/hr) of the trap is based on the differential pressure across the trap. The condensate loads (lbs/hr) for process applications are normally calculated at the maximum steam pressure; then an appropriate safety margin is applied in order to select a trap with sufficient capacity when operating at lower steam pressures. Reference full explanation of Safety Load Factors in Steam Traps Introduction section.

When a temperature control valve is regulating flow to the process equipment, it is recommended to select a trap with a PMO that will exceed the inlet steam pressure to the control valve.

For Example: Process application has a maximum steam inlet pressure of 100 psi, a maximum condensate load of 10,000 lbs/hr and is discharging to a condensate return line with a possible back pressure of 25 psig. ΔP = 100-25 = 75 PSI

To select trap: If the Safety Load Factor is chosen to be 2X max capacity at max differential pressure, then Trap should be selected based on 20,000 lbs/hr (10,000 x 2 = 20,000) at 75 PSI differential pressure with a PMO in excess of 100 PSIG

Selection: FTE-200-17-N, PMO=200 PSIG, 2" NPT with a condensate capacity of 21,500 lbs/hr at 75 PSI differential pressure.

CAPACITIES – Condensate (lbs/hr)																			
Model Code	PMO (PSIG)	Pipe Size	Orifice Size	ΔP = Differential Pressure (PSI)															
				1/4	1/2	1	2	5	10	15	20	30	50	75	100	125	200	250	300
FTE-20-17-N*	20	2"	.937"	6100	7800	9300	11800	15900	19500	22500	26000								
FTE-50-17-N	50	2"	2.125"	12800	16900	20100	25300	33000	40200	43500	46000	47800	52500						
FTE-50-18-N	50	2 1/2"	2.125"	20400	25700	31000	37000	46300	55100	60300	65100	72000	82100						
FTE-125-18-N	125	2 1/2"	2.125"	20400	25700	31000	37000	46300	55100	60300	65100	72000	82100	90400	97700	105000			
FTE-200-16-N	200	1 1/2"	.375"	950	1350	1900	2200	2700	3300	3900	4400	5300	6400	7600	8500	9400	11900		
FTE-200-17-N	200	2"	.75"	2700	4100	5700	7400	9900	11800	13400	14400	16400	19000	21500	23000	24500	29200		
FTE-200-18-N	200	2 1/2"	1.5"	7200	12300	17400	21500	27600	32600	36000	39300	43100	49200	54700	58800	61900	74000		
FTES-50-18-N	50	2 1/2"	2.125"	20400	25700	31000	37000	46300	55100	60300	65100	72000	82100						
FTES-125-18-N	125	2 1/2"	2.125"	20400	25700	31000	37000	46300	55100	60300	65100	72000	82100	90400	97700	105000			
FTES-300-18-N	300	2 1/2"	1.5"	7200	12300	17400	21500	27600	32600	36000	39300	43100	49200	54700	58800	61900	74000	86000	100550

* Single seat orifice. All others are double seated.

Steam Traps

Float & Thermostatic Steam Trap

FT600 & FT601

Float & Thermostatic

Model	FT600 & FT601*
Sizes	3/4", 1", 1 1/2", 2", 3", 4"
Connections	NPT, SW, FLG
Body Material	Carbon Steel or 316SS
Options	Live Orifice Air Vent
PMO Max. Operating Pressure	450 PSIG
TMO Max. Operating Temperature	750°F
PMA Max. Allowable Pressure	990 PSIG @ 100°F
TMA Max. Allowable Temperature	750°F @ 670 PSIG

* FT601 Body Material is 316 SS
 FT600 Body Material is Carbon Steel

Typical Applications

PROCESS: FT600 Series steam traps with Cast Steel Body were specifically designed for removing condensate and air from higher pressure steam applications or where steel bodies are specified. They are typically used in chemical plants and petrochemical refineries on re-boilers, heat exchangers, and other critical process applications. The excellent air-handling capability of float and thermostatic traps make them a better choice than bucket traps for applications requiring quick system start-up. Maximum steam pressure is 450 PSIG. Note: Model FT601 is identical to FT600 except body material is 316 SS.

How It Works

Float and thermostatic traps contain a float and seat mechanism with a separate thermostatic element which work together to remove both condensate and air from the steam system. The float, which is attached to a valve, rises and opens the valve when condensate enters the trap. This allows the condensate to discharge. Air is discharged through the thermostatic air vent to the outlet side of the trap. Steam entering the trap causes the thermostatic element to expand, closing the air vent and trapping the steam.

Features

- Investment cast steel body and cover with class 400 shell rating (670 PSIG @ 750°F)
- Hardened stainless steel seat and disc for extended service life even at extreme temperatures and pressures
- Excellent air handling capability allows air to be discharged rapidly so steam can enter the system quickly during start-up
- In-line repairability is simplified by having all internals attached to the cover. Studded cover allows for easier removal of body.
- Welded stainless steel air vent resists shock from waterhammer. Live orifice air vent is available for superheated applications
- F&T traps discharge condensate immediately as it is formed (no condensate will back up into the system)



Options

Live orifice air vent for superheated applications.

Sample Specification

The steam trap shall be of the mechanical float type having cast steel bodies, horizontal in-line connections in NPT, SW, or flanged, and all stainless steel internals. Incorporated into the trap body shall be an all stainless steel welded thermal element air vent which is water hammer resistant. The air vent is to be located at the high point of trap body to assure proper venting of non-condensables. The trap body will be in-line renewable. All bodies and covers shall be class 400 shell design, suitable for 670 PSIG @ 750°F.

Installation and Maintenance

The trap must be installed upright and level for the float mechanism to operate properly. All internal components can be replaced while the steam trap remains connected to the piping (in-line repairable). Threaded studs are permanently installed into the cover assembly which greatly simplifies the removal and replacement of the body when servicing. Internal components include a high quality welded stainless steel thermostatic air vent and stainless steel seat and mechanism. The standard thermostatic air vent can be damaged by superheat; therefore, in applications with superheated steam, the thermostatic air vent should be replaced with a special "live orifice" air vent.

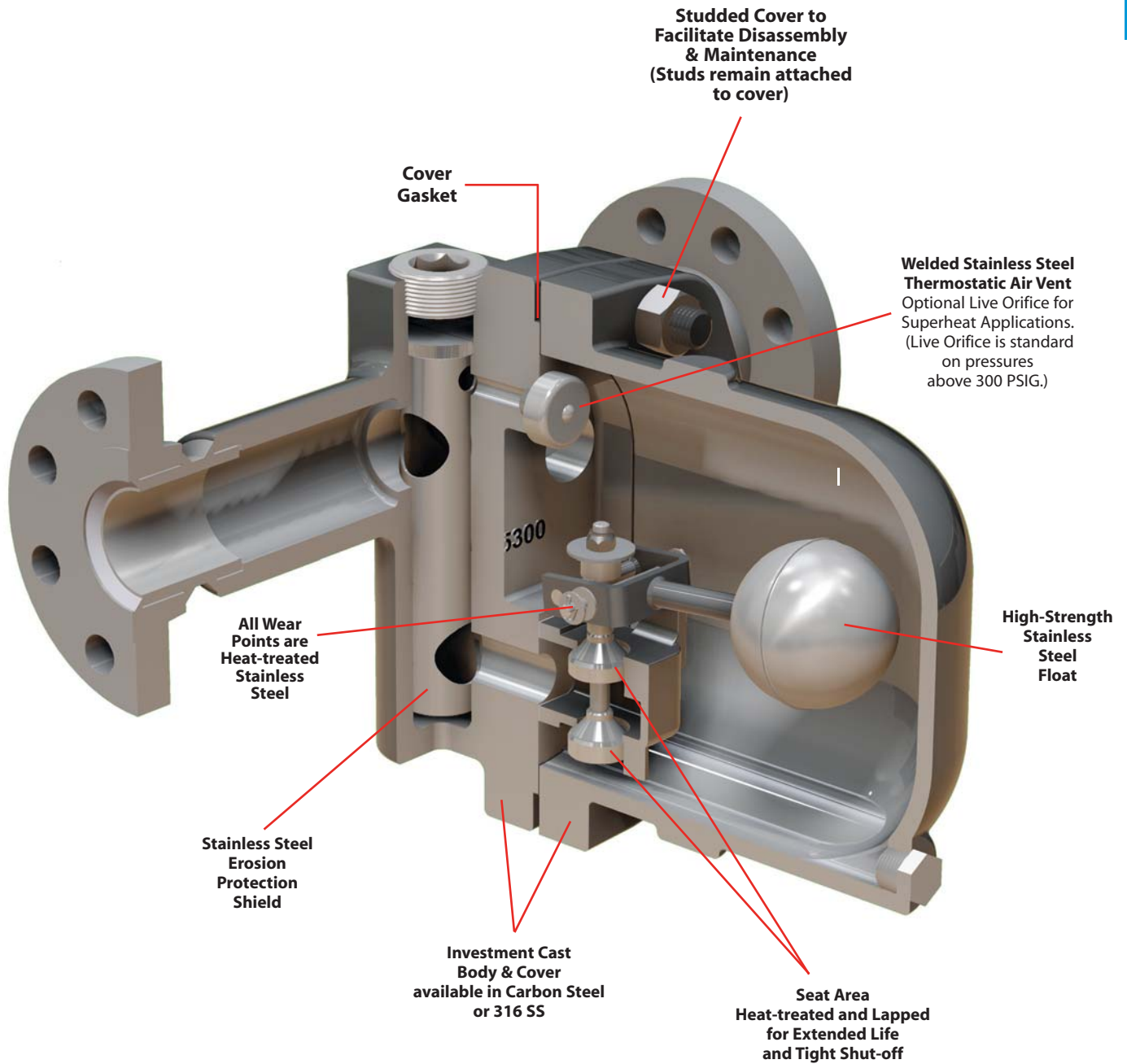

MATERIALS

FT 600: Body & Cover	Cast Steel, ASTM A-216
FT 601: Body & Cover	316 SS
Cover Studs	Steel, AS 193, GR B7
Cover Nuts	Steel, SA 194, GR 2H
Cover Gasket	Stainless Steel Reinforced Grafoil
Valve Assembly	Stainless Steel, AISI 431
Gasket, Valve Assembly	Stainless Steel Reinforced Grafoil
Pivot Assembly	Stainless Steel, 17-4 PH
Mounting Screws	Stainless Steel Hex Head, 18-8
Float	Stainless Steel, ASTM -240, 304
Air Vent Assembly	Thermostatic element 304 SS Optional: Live orifice

How to Size / Order

The maximum operating pressure (PMO) rating of model selected must meet or exceed the maximum steam pressure or the trap may not open. For example; the FT600-145 has a PMO of 145 psi. Condensate capacity (lbs/hr) of the trap is based on the differential pressure across the trap.

For drip applications, a (3/4)" FT600 size is sufficient to exceed warm-up loads with a 2X safety factor. The condensate loads (lbs/hr) for process applications are normally calculated at the maximum steam pressure; then an appropriate safety margin is applied in order to select a trap with sufficient capacity when operating at lower steam pressures. Reference full explanation of Safety Load Factors in Steam Traps Introduction section.

When a temperature control valve regulates the flow of steam to the process equipment (Heat Exchanger) being drained of condensate, it is recommended to select a trap with a PMO that exceeds the inlet steam pressure to the temperature control valve. This assures that under all operating conditions, the steam pressure will not exceed the PMO of the trap.

For Example: Process application has a maximum steam inlet pressure of 100 psi, a maximum condensate load of 2,500 lbs/hr and is discharging to a condensate return line with a possible back pressure of 20 psig. $\Delta P = 100 - 20 = 80$ PSI
To select trap: If the Safety Load Factor is chosen to be 2X max capacity at max differential pressure, then Trap should be selected based on 5,000 lbs/hr (2,500 x 2 = 5,000) at 80 PSI differential pressure with a PMO in excess of 100 PSIG
Selection: FT600-145-16-N, PMO=145 PSIG, 1 1/2" NPT with a condensate capacity of 9,900 lbs/hr at 80 PSI differential pressure.

Connection Codes:
(N=NPT, SW=Socket Weld, F150=150# FLG, F300=300# FLG, F600=600# FLG)

CAPACITIES – Condensate (lbs/hr)		$\Delta P = \text{Differential Pressure (PSI)}$																			
Model Code*	PMO (PSIG)	Sizes	1	2	3	4	5	10	20	30	40	50	65	80	100	145	200	300	400	450	
FT600-65-13-N	65	3/4"	225	300	363	413	463	635	960	1060	1180	1320	1460								
FT600-65-14-N	65	1"	775	1094	1340	1520	1690	2370	3260	3990	4500	5000	5500								
FT600-65-16-N	65	1 1/2"	2500	3450	4130	4750	5300	7500	10625	13125	15000	16800	18850								
FT600-65-17-N	65	2"	8500	11950	14670	16800	18700	25250	35900	43000	49600	55500	61250								
FT600-145-13-N	145	3/4"	137	180	218	250	275	380	520	625	725	863	895	995	1120	1315					
FT600-145-14-N	145	1"	400	555	660	755	850	1237	1593	1925	2240	2490	2750	3000	3430	3935					
FT600-145-16-N	145	1 1/2"	1275	1750	2125	2430	2740	3750	5100	6250	7200	7995	8875	9900	11250	13300					
FT600-145-17-N	145	2"	3125	4400	5375	6250	6900	9250	14625	16875	19375	21875	25000	27500	31000	37000					
FT600-200-13-N	200	3/4"	93	137	160	187	205	287	400	487	560	610	710	775	875	1060	1250				
FT600-200-14-N	200	1"	300	410	487	560	610	925	1140	1375	1520	1687	1875	2060	2312	2750	3100				
FT600-200-16-N	200	1 1/2"	825	1130	1400	1570	1760	25000	375	4125	4740	5250	6000	6600	7300	8650	10200				
FT600-200-17-N	200	2"	1560	2187	2800	3100	3490	4800	6750	8250	9500	10625	12400	13700	15000	18120	21200				
FT600-300-13-N	300	3/4"	50	68	83	95	106	155	197	240	275	300	340	375	413	490	570	710			
FT600-300-14-N	300	1"	225	300	363	413	463	635	960	1060	1180	1320	1468	1640	1815	2130	2550	3000			
FT600-300-16-N	300	1 1/2"	825	1130	1400	1570	1760	25000	375	4125	4740	5250	6000	6600	7300	8650	10200	12600			
FT600-300-17-N	300	2"	1560	2187	2800	3100	3490	4800	6750	8250	9500	10625	12400	13700	15000	18120	21200	26250			
FT600-450-13-N	450	3/4"	32	42	49	56	62	84	119	145	163	175	192	210	186	275	312	375	425	450	
FT600-450-14-N	450	1"	137	180	218	250	275	380	520	625	725	863	895	995	1120	1315	1500	1870	2125	2250	
FT600-450-16-N	450	1 1/2"	825	1130	1400	1570	1760	2500	3375	4125	4740	5250	6000	6600	7300	8650	10200	12600	14375	15200	
FT600-450-17-N	450	2"	1560	2187	2800	3100	3490	4800	6750	8250	9500	10625	12400	13700	15000	18120	21200	26250	28700	31250	

Note: For 450 Model, the Thermostatic Air Vent is replaced with a live Orifice.

* Chart is applicable for both Models FT600 & FT601

FT600 & FT601:
 3/4", 1", 1 1/2", 2"

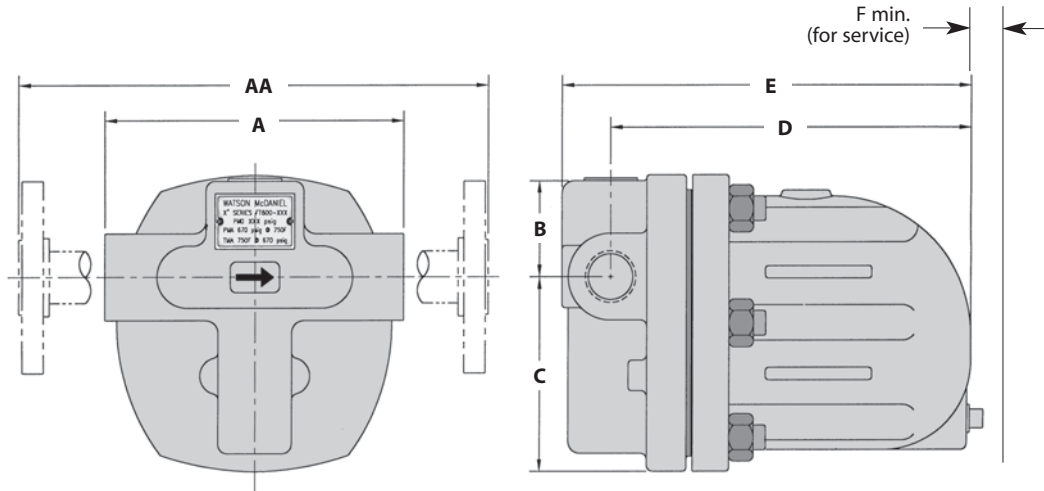

DIMENSIONS & WEIGHTS – inches									
Model* Size	A	AA	B	C	D	E	F	Weight (lbs)	
								NPT/SW	FLG
FT600 3/4"	6.10	10.10	2.07	3.93	7.38	8.41	5.75	25	31
FT600 1"	6.50	10.40	2.50	5.50	8.44	9.50	6.25	31	36
FT600 1 1/2"	9.80	14.00	3.26	6.85	10.40	11.94	7.75	82	91
FT600 2"	11.80	16.00	3.60	7.40	11.59	13.27	8.00	93	107

* Chart is applicable for FT600 & FT601

Typical Applications for Float & Thermostatic Steam Traps

Shell & Tube Heat Exchanger Application:

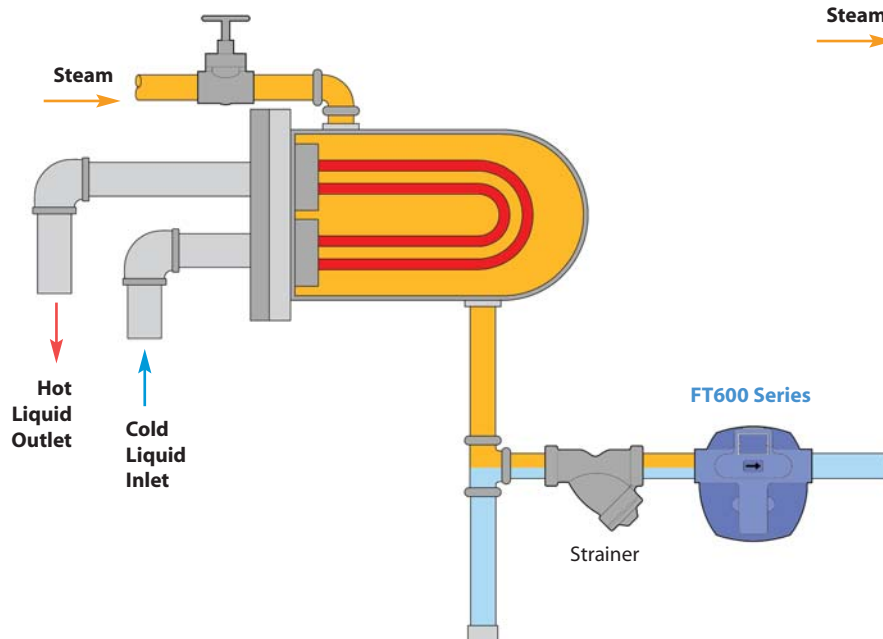

Steam Main Drip Application

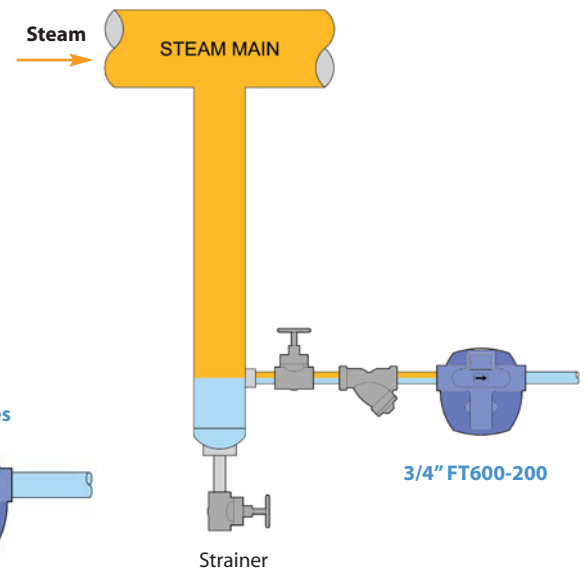

Steam Traps

Float & Thermostatic Steam Trap

FT600 & FT601

Float & Thermostatic

Model	FT600 & FT601*
Sizes	3", 4"
Connections	NPT, SW, FLG
Body Material	Carbon Steel or 316SS
PMO Max. Operating Pressure	450 PSIG
TMO Max. Operating Temperature	750°F
PMA Max. Allowable Pressure	990 PSIG @ 100°F
TMA Max. Allowable Temperature	750°F @ 670 PSIG

* **FT601 Body Material is 316 SS**
FT600 Body Material is Carbon Steel

3" & 4" FT600 & FT601 contain an open orifice air vent.
 If a thermostatic air vent is required, contact factory.

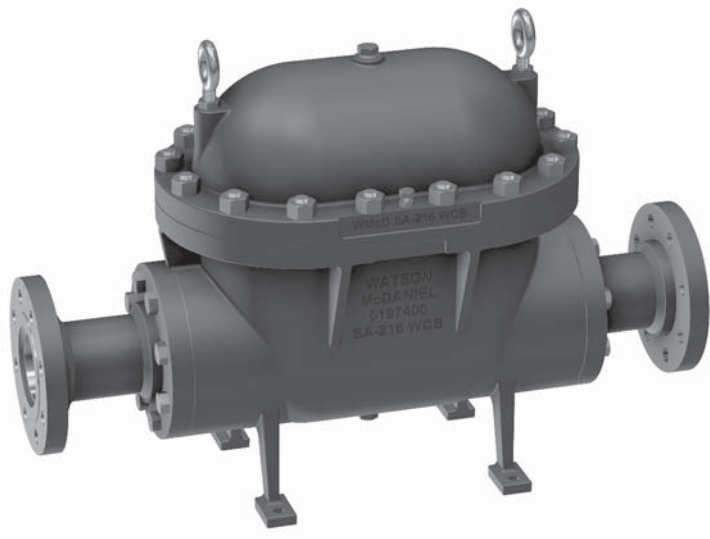

PRESSURE-TEMPERATURE RATING - 3" & 4" Models

PMA 650 PSIG up to 450°F
TMA 750°F @ 375 PSIG

Size	Conn	PMO (PSIG)	Model Code
3"	NPT	450	FT600-450-19-N
3"	SW	450	FT600-450-19-SW
3"	150 # Flg	285	FT600-285-19-F150
3"	300 # Flg	450	FT600-450-19-F300
3"	600 # Flg	450	FT600-450-19-F600
4"	150 # Flg	285	FT600-285-20-F150
4"	300 # Flg	450	FT600-450-20-F300
4"	600 # Flg	450	FT600-450-20-F600

CAPACITIES — Condensate (1000 lbs/hr)

Temp	Differential Pressure (PSI)																				
	1/2	1	2	5	10	15	20	30	40	50	75	100	125	150	175	200	250	300	350	400	450
COLD*	44	59	81	122	170	205	230	280	317	350	425	480	540	580	625	670	740	800	860	910	960
HOT	44	53	64	83	100	112	121	138	149	159	177	190	201	212	222	230	247	260	270	280	290

* Cold Water capacities are to be used when the trap is used as a liquid drain trap.
 Note: For liquid drain trap applications, please specify "liquid drain trap" when ordering.

CAPACITY CORRECTION FACTORS

To obtain capacity with a liquid other than water, multiply water capacity by correction factor.

Spec. Gravity	1	.98	.96	.94	.92	.90	.88	.86	.84	.82	.80	.75	.70	.65	.60	.55	.50
Corr. Factor	1	.990	.980	.970	.959	.949	.938	.927	.917	.906	.894	.866	.837	.806	.775	.742	707

FT600 & FT601:
3" & 4"

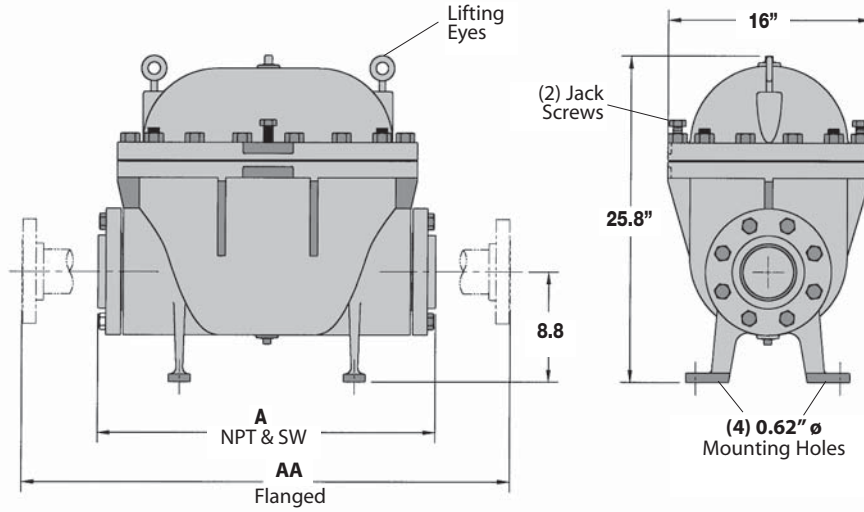

DIMENSIONS & WEIGHTS – inches					
Model*	Size	A	AA	Weight (lbs)	
				Connection	FLG
FT600	3"	27	39	587 (NPT, SW)	626
FT600	4"	27	39	587 (SW)	654

* Chart is applicable for both Models FT600 & FT601

FT600: 3" - 4" :
Process: Refinery Reboiler Application

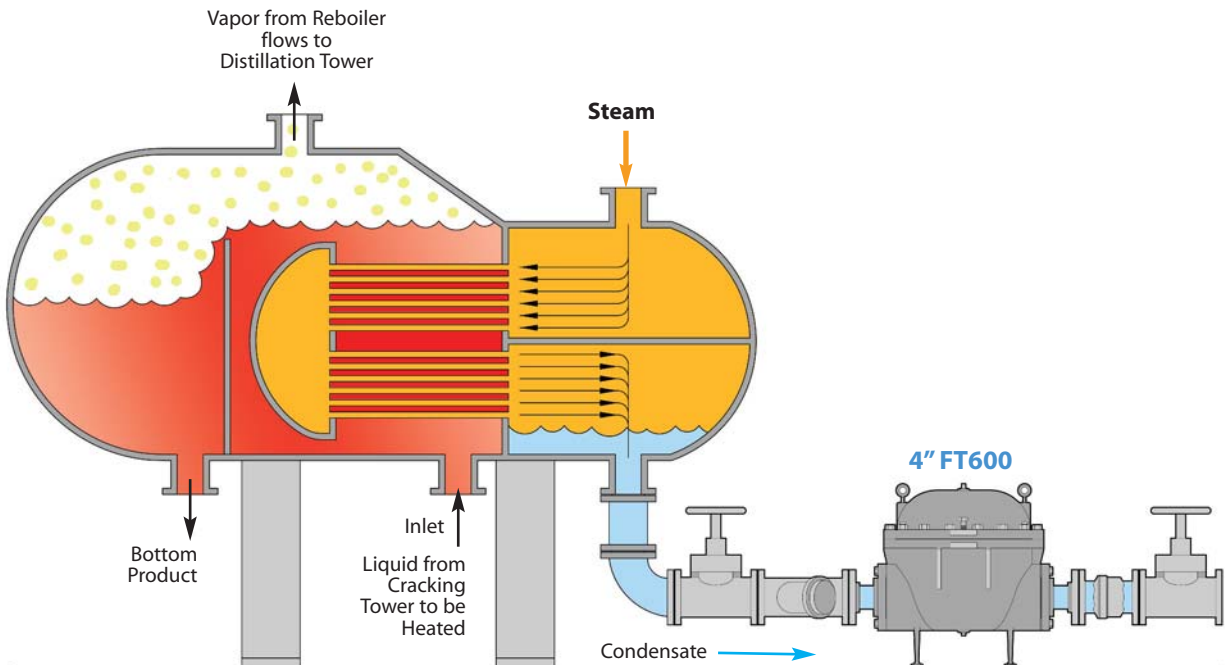

Model	FT
Sizes	3/4", 1", 1 1/4", 1 1/2", 2"
Connections	NPT
Body Material	Cast Iron
PMO Max. Operating Pressure	75 PSIG
TMO Max. Operating Temperature	Saturated Steam Temperature
PMA Max. Allowable Pressure	75 PSIG up to 450°F
TMA Max. Allowable Temperature	450°F @ 75 PSIG



Typical Applications

DRIP, PROCESS: FT Series steam traps are designed for operating pressures up to 75 PSIG. These float and thermostatic traps are used for lower pressure HVAC and light industrial process applications. They are used on unit heaters, water heaters, pressing machines, heat exchangers and coils. For drip applications, such as draining steam mains and steam supply lines, use 3/4" FT-075 (FT73-075-13-N). F&T traps have excellent air-handling capability, which make them a better choice than Inverted Bucket traps for most process applications. FT Series traps have a dual inlet-outlet H-Pattern connection allowing for additional flexibility in installation.

How It Works

Float and thermostatic traps contain a float and seat mechanism with a separate thermostatic element which work together to remove both condensate and air from the steam system. The float, which is attached to a valve, rises and opens the valve when condensate enters the trap. This allows the condensate to discharge. Air is discharged through the thermostatic air vent to the outlet side of the trap. Steam entering the trap causes the thermostatic element to expand, closing the air vent and trapping the steam.

Sample Specification

The trap shall be of float and thermostatic design with cast iron body. Thermostatic element to be welded stainless steel. Float and seating material to be stainless steel. Trap must be in-line repairable.

Features

- H-pattern design allows piping from either side of the steam trap (there are two inlet ports at top and two outlet ports at bottom)
- F&T traps have excellent air handling capability allows air to be discharged rapidly and steam to enter the system quickly during start-up
- Welded stainless steel thermostatic air vent resists shock from waterhammer
- In-line repairable (all internals are attached to cover)

Installation and Maintenance

The trap must be installed upright and level for the float mechanism to operate properly. All internal components can be replaced with the trap body piped in-line. Repair kit includes thermostatic element, valve seat and disc, float and sealing gasket.

Helpful Selection Information

Select a model that can handle the maximum working pressure of the steam system. For example, the FT3-015 has a maximum working pressure of 15 PSI. Consult capacity tables to properly size unit. Available in 3/4" through 2" NPT connections. Select these models for steam systems with maximum working pressure of 75 PSIG.

Demonstration of H-Style piping connections:

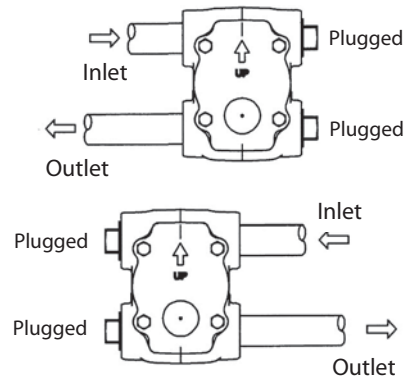
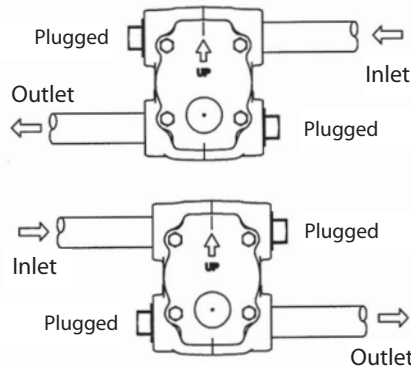

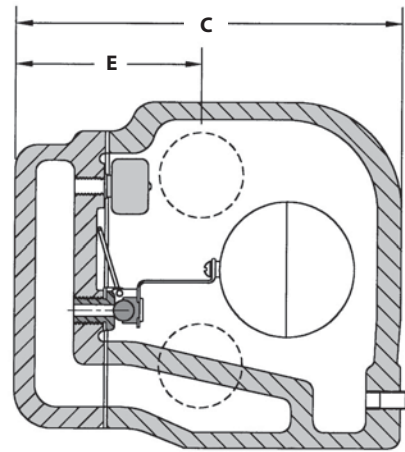
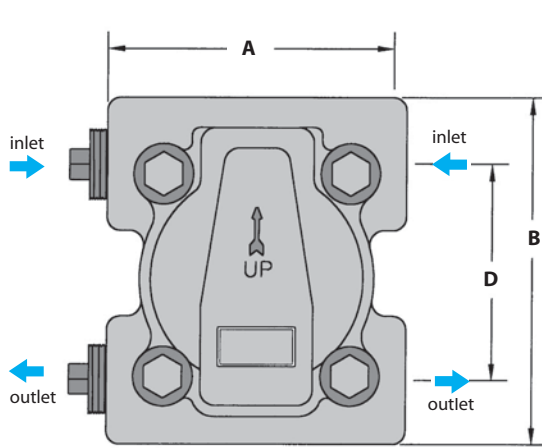

DIMENSIONS & WEIGHTS – inches/pounds						
Model	A	B	C	D	E	Weight
FT-3, FT-4, FT-33 FT-34, FT-73, FT-74	4.125	5.00	5.125	3.125	2.75	7.50
FT-6, FT-35, FT-36 FT-75, FT-76	5.00	6.81	6.47	4.125	3.43	13.0
FT-7, FT-37L, FT-77L	6.375	7.68	8.218	5.25	4.41	21.0
FT-8, FT-38, FT-78 FT-S8-15, FT-S8-75	6.50	11.0	8.968	7.468	4.531	40.0

MATERIALS	
Body & Cover	Cast Iron, ASTM A-126 Class B
Nuts & Bolts	High-Tensile Steel
Gasket	Grafoil/Garlock
Float	Stainless Steel
Valve & Seat	Stainless Steel
Thermostatic Assembly	Stainless Steel Bellows & Valve

How to Size / Order

The maximum operating pressure (PMO) rating of model selected must meet or exceed the maximum steam pressure or the trap may not open. For example; the FT-35-030 has a PMO of 30 psi. For drip applications, a 3/4" FT size is sufficient to exceed warm-up loads with a 2X safety factor. The condensate loads (lbs/hr) for process applications are normally calculated at the maximum steam pressure; then a safety margin is applied in order to select a trap with sufficient capacity at lower pressures. Reference full explanation of Safety Load Factors in Steam Traps Introduction section.

For Example: Process application has a maximum steam inlet pressure of 50 psi, a maximum condensate load of 1,700 lbs/hr and is discharging to a condensate return line with a possible back pressure of 10 psig. $\Delta P = 50 - 10 = 40$ PSI

To select trap: If the Safety Load Factor is chosen to be 2X max capacity at max differential pressure, then Trap should be selected based on 3,400 lbs/hr (1,700 x 2 = 3,400) at 40 PSI differential pressure with a PMO in excess of 50 PSIG

Selection: FT77L-075-16-N, PMO=75 PSIG, 1 1/2" NPT with a condensate capacity of 3,750 lbs/hr at 40 PSI differential pressure.

CAPACITIES – Condensate (lbs/hr)

Model Code	PMO (PSIG)	Pipe Size	Orifice Size	$\Delta P =$ Differential Pressure (PSI)															
				1/4	1/2	1	2	3	5	10	15	20	25	30	40	50	60	75	
FT3-015-13-N	15	3/4"	9/32"	340	440	600	830	990	1280	1790	2150								
FT4-015-14-N	15	1"	9/32"	340	440	600	830	990	1280	1790	2150								
FT6-015-15-N	15	1 1/4"	25/64"	850	1100	1460	2000	2350	2950	4000	4800								
FT7-015-16-N	15	1 1/2"	1/2"	1300	1700	2050	2550	2900	3500	4400	5300								
FT8-015-17-N	15	2"	21/32"	2500	3150	4000	5700	6100	6800	8300	9800								
FTS8-015-17-N	15	2"	15/16"	4400	5850	7400	9200	10300	12600	15300	18100								
FT33-030-13-N	30	3/4"	11/64"	220	300	405	530	650	890	1210	1485	1705	1865	2010					
FT34-030-14-N	30	1"	11/64"	220	300	405	530	650	890	1210	1485	1705	1865	2010					
FT35-030-14-N	30	1"	1/4"	450	600	880	1205	1420	1845	2560	3230	3715	4100	4405					
FT36-030-15-N	30	1 1/4"	1/4"	450	600	880	1205	1420	1845	2560	3230	3715	4100	4405					
FT37L-030-16-N	30	1 1/2"	7/16"	600	800	1200	1680	2210	2600	3500	4500	5200	5700	6100					
FT38-030-17-N	30	2"	13/32"	1550	2045	2625	3560	4260	5660	7890	9440	10500	11360	12095					
FT73-075-13-N	75	3/4"	9/64"	140	195	265	360	430	580	770	990	1110	1210	1290	1430	1560	1680	1830	
FT74-075-14-N	75	1"	9/64"	140	195	265	360	430	580	710	990	1110	1210	1290	1430	1560	1680	1830	
FT75-075-14-N	75	1"	#16	270	360	485	660	780	1020	1430	1740	1980	2200	2420	2670	2910	3135	3370	
FT76-075-15-N	75	1 1/4"	#16	270	360	485	660	780	1020	1430	1740	1980	2200	2420	2670	2910	3135	3370	
FT77L-075-16-N	75	1 1/2"	5/16"	340	460	690	900	1200	1400	1900	2350	2700	3000	3250	3750	4150	4500	4700	
FT78-075-17-N	75	2"	5/16"	800	1075	1300	1700	2000	2600	3750	4350	4700	5050	5400	5960	6500	6950	7550	
FTS8-075-17-N	75	2"	13/32"	1360	1800	2100	2800	3300	4300	6300	7300	8000	8500	9000	10000	11000	11600	12500	

Inverted Bucket

Model	Body Material	PMO (PSIG)	Sizes	Connections	Page No.
SIB/SIBH	Stainless Steel	450	1/2", 3/4"	NPT, SW	86
IB Series 103X/104X	Cast Iron	250	1/2" – 1 1/2"	NPT	88

PMO = Maximum Operating Pressure

Inverted Bucket Traps

The Inverted Bucket Trap, with its rugged design, offers features that are advantageous in certain conditions. The discharge orifice of the IB is mounted at the top of the trap, making them less susceptible to failure from dirt and pipe scale when compared to other trap types. Although they are typically not the primary choice for process applications due to their lack of air venting capability, they are often used in drip applications. They can be used on less critical process applications which do not require venting of air during system start-up or when a secondary air vent is added to the system.

SIB Series Stainless Steel Body



SIB/SIBH

IB Series Cast Iron Body (No Strainer)



1031

1032

1033

1034

IB Series Cast Iron Body (with Strainer)



1041

1042

1044 & 1038S

Introduction

INVERTED BUCKET TRAPS.

Operation:

Due to its weight, the inverted bucket within the trap will rest on the bottom of the trap body keeping the valve open and allowing condensate to be discharged (**Figure A**). In the top of the bucket there is a small bleed hole which allows air to escape from inside the bucket and exit through the outlet port (**Figure B**). When steam arrives through the inlet of the trap, it fills the inverted bucket which makes it buoyant and rise to the top of the trap, closing the valve (**Figure C**). As steam condenses and/or is bled through the small bleed hole in the top of the bucket, the bucket loses buoyancy which causes it to sink to the bottom of the trap. The valve then opens allowing condensate to be discharged from the system (**Figure A**). The bucket trap must maintain a certain amount of water (prime) in order to operate. If the trap loses its prime, the bucket will not be able to float when steam enters; keeping the valve in the open position which allows steam to escape (**Figure D**). Due to the balance of forces required between the incoming pressure and internal trap components, several orifice sizes are required to accommodate various differential pressure ranges. For this reason care must be used to select a trap model with an equal or higher PMO rating than the steam pressure.

A) Discharging Condensate

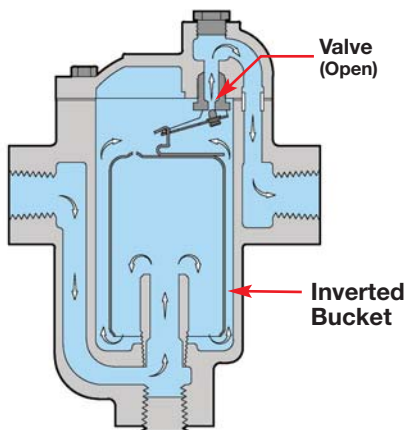

B) Discharging Air

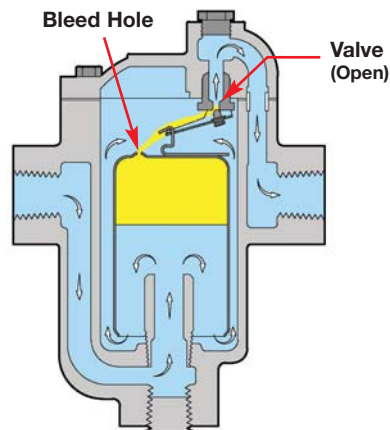

A) With condensate completely filling the trap, the bucket is in the down position with the valve open, allowing condensate to be discharged.

B) Small amounts of air will pass thru the bleed hole on top of the bucket and be discharged. (Note: Large amounts of air will lift the bucket and close off the trap, temporarily air locking the system.)

C) When steam enters the trap, the inverted bucket fills with steam and floats to the surface, closing off the valve, preventing steam from escaping.

C) Closed (Trapping Steam)

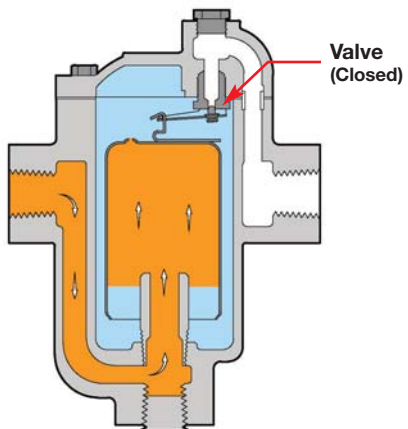

**D) Potential Failure Mode
Loss of Prime**

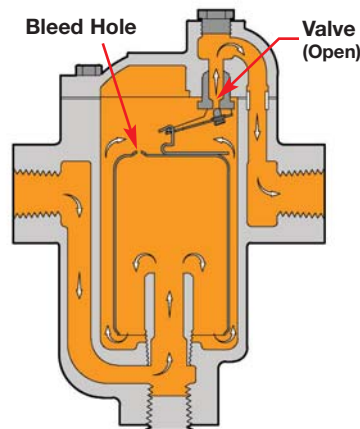

D) Potential Failure Mode: Bucket traps must maintain a water prime to function properly. If the prime is lost, the bucket will remain in the down position with the valve open, and live steam will be discharged from the system.

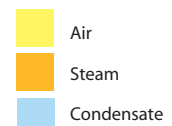

Steam Traps

Inverted Bucket Steam Trap

SIB/SIBH
Inverted Bucket

Model	SIB, SIBH
Size	1/2", 3/4"
Connections	NPT, SW
Body Material	Stainless Steel
PMO Max. Operating Pressure	450 PSIG*
TMO Max. Operating Temperature	750°F
PMA Max. Allowable Pressure	720 PSIG @ 100°F
TMA Max. Allowable Temperature	750°F @ 400 PSIG

Typical Applications

DRIP, TRACING: The **SIB & SIBH** Inverted Bucket Steam traps are suitable for removing condensate from steam mains and steam supply lines. They are also used on unit heaters, laundry equipment, and other smaller, low capacity and less critical process applications where slow start-up can be tolerated. The discharge orifice of the inverted bucket trap is mounted at the top of the trap body, which makes them less susceptible to failure from dirt and debris when compared to other trap types. The SIBH is physically larger and has a higher pressure capability for a particular orifice size than the SIB.

How It Works

When the trap is filled with condensate, the inverted bucket inside the steam trap loses its buoyancy and rests on the bottom of the trap. This pulls the disc off the seat allowing condensate to be discharged through the seat orifice located at the top of the trap. When steam enters, it fills the inverted bucket causing the bucket to float to the surface which closes the discharge valve, containing the steam in the system. Eventually, the steam is bled off through a small hole in the top of the bucket causing it to sink, which repeats the cycle.

Features

- All stainless steel body
- Acceptable for superheated steam (with check valve installed at inlet)
- Waterhammer resistant
- Valve & seat are located at the top of the trap body making them less prone to clogging from debris and pipe scale
- All stainless steel internals with hardened valve & seat



SIB
Inverted Bucket Steam Trap

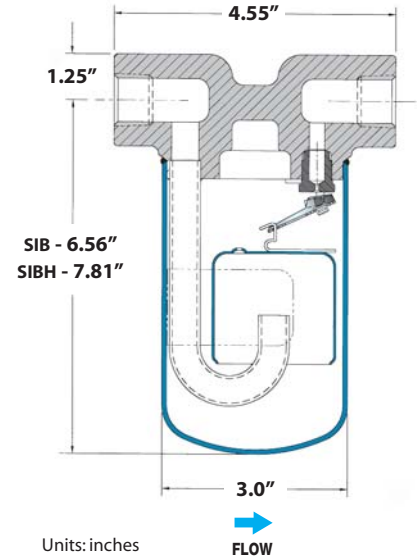

Sample Specification

Steam trap shall be an all stainless steel module design inverted bucket type with a frictionless valve lever assembly.

Option

Internal Check Valve

Installation and Maintenance

Trap must be installed in upright position to function properly. The stainless steel body is seal welded and therefore non-repairable. If a new trap is required, remove and replace. Bucket traps require an internal water seal to operate. Applications with superheated steam can cause the water seal to flash into steam and trap to fail in open position. A check valve installed at trap inlet will help prevent the loss of prime.

MATERIALS

Body	Stainless Steel GR CF3
Cover	304L Stainless Steel
Internals	300 Series Stainless Steel
Valve Plug & Seat	420F Stainless Steel

CAPACITIES – Condensate (lbs/hr)

Model	Orifice Size	PMO (PSIG)	Differential Pressure (PSI)																				
			5	10	15	20	25	30	40	50	60	70	80	100	125	150	180	200	250	350	450		
SIB-20	3/16"	20	450	560	640	690																	
SIB-80	1/8"	80	300	350	400	440	460	500	550	580	635	660	690										
SIB-150	#38	150	210	250	280	300	320	350	380	400	420	450	470	500	550	570							
SIB-450	.057	450	31	50	70	84	95	105	120	133	145	152	160	174	187	198	208	215	228	248	263		
SIBH-15	1/4"	15	830	950	1060																		
SIBH-30	3/16"	30	530	700	820	880	950	1000															
SIBH-70	5/32"	70	380	500	560	620	680	710	770	840	90	950											
SIBH-125	1/8"	125	285	375	440	485	530	560	620	670	720	780	800	860	950								
SIBH-200	7/64"	200	205	265	315	350	385	410	465	500	580	590	620	650	700	810	840	860					
SIBH-250	#38	250	155	205	240	270	295	320	360	400	500	530	550	580	630	660	690	710	760				
SIBH-450	.057	450	31	50	70	84	95	105	120	133	145	152	160	174	187	198	208	215	228	248	263		

Helpful Selection Information

The PMO (maximum operating pressure) rating of model selected must meet or exceed the maximum steam pressure or the trap may not open. For example; the **SIB-12-N-150** has a PMO of 150 PSI. Condensate capacity (lbs/hr) of the trap is based on the differential pressure across the trap.



SIB
Inverted Bucket
Steam Trap



SIBH
Inverted Bucket
Steam Trap

Size/ Connection	Model Code	PMO PSI	Weight lbs	Cross Reference	
				Spirax Sarco	Armstrong
1/2" NPT	SIB-12-N-20	20	5.0	SIB30	1810
3/4" NPT	SIB-13-N-20				
1/2" SW	SIB-12-SW-20				
3/4" SW	SIB-13-SW-20				
1/2" NPT	SIB-12-N-80	80	5.0	SIB30	1810
3/4" NPT	SIB-13-N-80				
1/2" SW	SIB-12-SW-80				
3/4" SW	SIB-13-SW-80				
1/2" NPT	SIB-12-N-150	150	5.0	SIB30	1810
3/4" NPT	SIB-13-N-150				
1/2" SW	SIB-12-SW-150				
3/4" SW	SIB-13-SW-150				
1/2" NPT	SIB-12-N-450	450	5.0	SIB30	1810
3/4" NPT	SIB-13-N-450				
1/2" SW	SIB-12-SW-450				
3/4" SW	SIB-13-SW-450				
1/2" NPT	SIBH-12-N-15	15	5.5	SIB30H	1811
3/4" NPT	SIBH-13-N-15				
1/2" SW	SIBH-12-SW-15				
3/4" SW	SIBH-13-SW-15				
1/2" NPT	SIBH-12-N-30	30	5.5	SIB30H	1811
3/4" NPT	SIBH-13-N-30				
1/2" SW	SIBH-12-SW-30				
3/4" SW	SIBH-13-SW-30				
1/2" NPT	SIBH-12-N-70	70	5.5	SIB30H	1811
3/4" NPT	SIBH-13-N-70				
1/2" SW	SIBH-12-SW-70				
3/4" SW	SIBH-13-SW-70				
1/2" NPT	SIBH-12-N-125	125	5.5	SIB30H	1811
3/4" NPT	SIBH-13-N-125				
1/2" SW	SIBH-12-SW-125				
3/4" SW	SIBH-13-SW-125				
1/2" NPT	SIBH-12-N-200	200	5.5	SIB30H	1811
3/4" NPT	SIBH-13-N-200				
1/2" SW	SIBH-12-SW-200				
3/4" SW	SIBH-13-SW-200				
1/2" NPT	SIBH-12-N-250	250	5.5	SIB30H	1811
3/4" NPT	SIBH-13-N-250				
1/2" SW	SIBH-12-SW-250				
3/4" SW	SIBH-13-SW-250				
1/2" NPT	SIBH-12-N-450	450	5.5	SIB30H	1811
3/4" NPT	SIBH-13-N-450				
1/2" SW	SIBH-12-SW-450				
3/4" SW	SIBH-13-SW-450				

Model	1031, 1032, 1033, 1034, 1041, 1042, 1044, 1038S
Sizes	1/2", 3/4", 1", 1 1/4", 1 1/2"
Connections	NPT
Body Material	Cast Iron
Options	Internal check valve, Thermic vent
PMO Max. Operating Pressure	250 PSIG
TMO Max. Operating Temperature	450°F
PMA Max. Allowable Pressure	250 PSIG up to 450°F
TMA Max. Allowable Temperature	450°F @ 250 PSIG



**1031/1032
1033/1034**
(No Strainer)



**1041/1042
1044/1038S**
(with Strainer)

Typical Applications

DRIP, TRACING PROCESS: IB Series inverted bucket steam traps are used in drip applications to remove condensate from steam mains and steam supply lines. For drip applications, the smaller sized units have adequate capacity. The discharge orifice of the inverted bucket trap is mounted at the top of the trap body, which makes them less susceptible to failure from dirt and debris when compared to other trap types. Since Inverted Bucket traps have poor air-handling capability, they are normally not recommended for most process applications. However, they can be used on certain process applications such as unit heaters and laundry equipment, where discharging air during system start-up is not a critical factor. F&T traps are the preferred choice for systems where air *must* be quickly discharged.

How It Works

When the trap is filled with condensate, the inverted bucket inside the steam trap loses its buoyancy and rests on the bottom of the trap. This pulls the disc off the seat allowing condensate to be discharged through the seat orifice located at the top of the trap. When steam enters, it fills the inverted bucket causing the bucket to float to the surface which closes the discharge valve, containing the steam in the system. Eventually, the steam is bled off through a small hole in the top of the bucket causing it to sink, which repeats the cycle.

Features

- Waterhammer resistant
- Suitable for superheated steam
(use internal check valve option to eliminate loss of prime)
- In-line repairability is simplified by having all internals attached to the cover
- Valve & seat are located at the top of the trap body making them less prone to clogging from debris and pipe scale
- All stainless steel internals with hardened valve & seat

Sample Specification

The steam trap shall be of an inverted bucket trap design.

Installation and Maintenance

Trap must be installed in upright position to function properly. All working components can be replaced with the trap body remaining in-line. With superheated steam, a check valve should be installed at inlet or trap may lose prime. A replacement kit containing the lever and seat assembly is a more economical option than replacing the entire steam trap. Also available are replacement screens, gaskets and buckets. When ordering replacement lever and seat assemblies, specify model and operating pressure. See Replacement Parts and Kits Section for exact cross-reference to Armstrong PCA (Pressure Change Assembly) kits.

Helpful Selection Information

Select a model with a higher maximum operating pressure (PMO) that meet or exceed the maximum steam pressure or the trap may not open. For example, the **IB-1032-14-N-250** has a PMO of 250 PSI. Choose a model that will handle the capacity requirement based on the differential pressure across the trap. Reference capacity charts.

Options

Strainer and Blowdown valve connection available on 1041, 1042, 1044 & 1038S. Thermic vent to improve air handling capability. Internal check valve for superheated or condensate backflow applications.

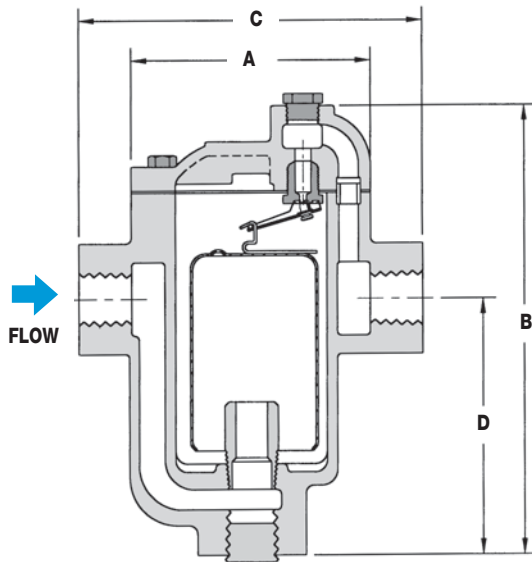

1031/1031S/1032/1033/1034
without Strainer (except 1031S)

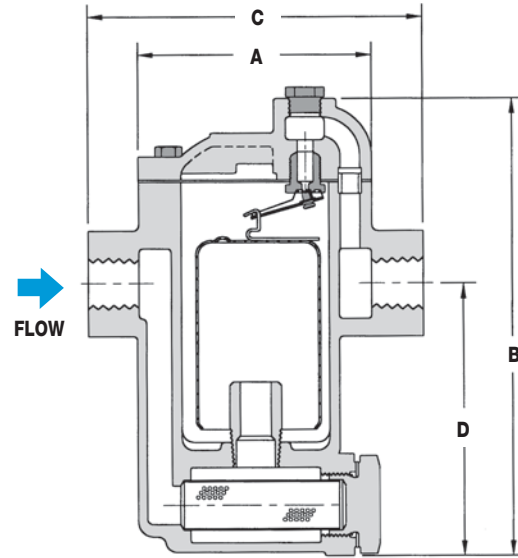

1041/1042/1044/1038S
with Strainer

DIMENSIONS & WEIGHTS – inches					
Model	A	B	C	D	Weight (lbs)
1031	3.75	5.875	5.00	2.75	5
1031S*	3.75	5.875	5.00	2.75	5
1032	3.75	6.875	5.00	4.25	6
1033	5.625	9.06	6.50	5.375	15
1034	7.00	11.75	7.75	7.03	27
1041*	3.75	6.06	5.00	3.43	5
1042*	3.75	7.06	5.00	4.43	6
1044*	7.00	12.375	7.125	7.375	30
1038S*	7.00	12.375	7.125	7.375	30

* With Integral Strainer

How to Order Options: (reference model code chart)

Check Valve (suffix CV)

Built-in Inlet Check Valve is recommended when used on Superheated Steam

Example: **IB1032-12-N-125-CV**

Thermic Vent (suffix TV)

A Thermic Vent is recommended when using a Bucket Trap on any type of process application or where the removal of air from the system is critical.

Example: **IB1032-12-N-125-TV**

Thermic Vent & Check Valve (suffix TCV)

For both Check Valve & Thermic Vent Options use Suffix Code

Example: **IB1032-12-N-125-TCV**

Blowdown Valve (add B to Model Code)

Blowdown connection is available on Models IB1038S, 1041, 1042 and 1044

Example: **IB1041B-13-N-150**

(Model IB1041, 3/4" NPT, 150 PSI max operating pressure with Blowdown & Strainer)

MATERIALS

Body & Cover	Cast Iron, ASTM A-278 Class 30
Nuts & Bolts	High-Tensile Steel
Gasket	Garlock
Bucket	Stainless Steel
Lever & Seat Assembly	Stainless Steel
Valve & Seat	Hardened Stainless Steel
Integral Strainer*	Stainless Steel

* 1031S, 1038S, 1041, 1042, 1044 models only.

How to Size / Order

From the capacity chart, select the model that can handle the working pressure of the system (PMO). Select the appropriate trap that will meet the capacity requirements at the differential pressure. Example:

Application: 1000 lbs/hr at 75 PSIG working pressure and 2 PSI differential pressure

Note: Specify Model, PMO and Connection Size

Size/Model: **IB-1034, 80 PSIG**, Specify pipe size (3/4", 1"), or **IB-1044, 80 PSIG**, Specify pipe size (3/4", 1")

Cross Reference Chart

NO STRAINER		STRAINER	
Watson McDaniel	Armstrong	Watson McDaniel	Armstrong
1031	800	1041	880
1032	811	1042	881
1033	812	1044	883
1034	813		

NO STRAINER

WITH STRAINER

Conn. NPT	Model Code	PMO PSI	Weight lbs	Cross Ref. Armstrong
1/2"	IB1031-12-N-20	20	7	800
3/4"	IB1031-13-N-20			
1/2"	IB1031-12-N-80	80	7	800
3/4"	IB1031-13-N-80			
1/2"	IB1031-12-N-125	125	7	800
3/4"	IB1031-13-N-125			
1/2"	IB1031-12-N-150	150	7	800
3/4"	IB1031-13-N-150			
1/2"	IB1032-12-N-15	15	8	811
3/4"	IB1032-13-N-15			
1"	IB1032-14-N-15	30	8	811
1/2"	IB1032-12-N-30			
3/4"	IB1032-13-N-30	70	8	811
1"	IB1032-14-N-30			
1/2"	IB1032-12-N-70	125	8	811
3/4"	IB1032-13-N-70			
1"	IB1032-14-N-70	200	8	811
1/2"	IB1032-12-N-125			
3/4"	IB1032-13-N-125	250	8	811
1"	IB1032-14-N-125			
1/2"	IB1032-12-N-200	250	8	811
3/4"	IB1032-13-N-200			
1"	IB1032-14-N-200	15	17	812
1/2"	IB1032-12-N-250			
3/4"	IB1032-13-N-250	30	17	812
1"	IB1032-14-N-250			
1/2"	IB1033-12-N-15	70	17	812
3/4"	IB1033-13-N-15			
1/2"	IB1033-12-N-70	125	17	812
3/4"	IB1033-13-N-70			
1/2"	IB1033-12-N-125	200	17	812
3/4"	IB1033-13-N-125			
1/2"	IB1033-12-N-200	250	17	812
3/4"	IB1033-13-N-200			
1/2"	IB1033-12-N-250	15	30	813
3/4"	IB1033-13-N-250			
1"	IB1034-14-N-15	30	30	813
3/4"	IB1034-13-N-15			
1"	IB1034-14-N-30	60	30	813
3/4"	IB1034-13-N-30			
1"	IB1034-14-N-60	80	30	813
3/4"	IB1034-13-N-60			
1"	IB1034-14-N-80	125	30	813
3/4"	IB1034-13-N-80			
1"	IB1034-14-N-125	180	30	813
3/4"	IB1034-13-N-125			
1"	IB1034-14-N-180	250	30	813
3/4"	IB1034-13-N-180			
1"	IB1034-14-N-250			

Conn. NPT	Model Code	PMO PSI	Weight lbs	Cross Ref. Armstrong
1/2"	IB1041-12-N-20	20	7	880
3/4"	IB1041-13-N-20			
1/2"	IB1041-12-N-80	80	7	880
3/4"	IB1041-13-N-80			
1/2"	IB1041-12-N-125	125	7	880
3/4"	IB1041-13-N-125			
1/2"	IB1041-12-N-150	150	7	880
3/4"	IB1041-13-N-150			
1/2"	IB1042-12-N-15	15	8	881
3/4"	IB1042-13-N-15			
1/2"	IB1042-12-N-30	30	8	881
3/4"	IB1042-13-N-30			
1/2"	IB1042-12-N-70	70	8	881
3/4"	IB1042-13-N-70			
1/2"	IB1042-12-N-125	125	8	881
3/4"	IB1042-13-N-125			
1/2"	IB1042-12-N-200	200	8	881
3/4"	IB1042-13-N-200			
1/2"	IB1042-12-N-250	250	8	881
3/4"	IB1042-13-N-250			
3/4"	IB1044-13-N-15	15	37	883
1"	IB1044-14-N-15			
3/4"	IB1044-13-N-30	30	37	883
1"	IB1044-14-N-30			
3/4"	IB1044-13-N-60	60	37	883
1"	IB1044-14-N-60			
3/4"	IB1044-13-N-80	80	37	883
1"	IB1044-14-N-80			
3/4"	IB1044-13-N-125	125	37	883
1"	IB1044-14-N-125			
3/4"	IB1044-13-N-180	180	37	883
1"	IB1044-14-N-180			
3/4"	IB1044-13-N-250	250	37	883
1"	IB1044-14-N-250			
1 1/4"	IB1038S-15-N-15	15	37	883
1 1/2"	IB1038S-16-N-15			
1 1/4"	IB1038S-15-N-30	30	37	883
1 1/2"	IB1038S-16-N-30			
1 1/4"	IB1038S-15-N-60	60	37	883
1 1/2"	IB1038S-16-N-60			
1 1/4"	IB1038S-15-N-80	80	37	883
1 1/2"	IB1038S-16-N-80			
1 1/4"	IB1038S-15-N-125	125	37	883
1 1/2"	IB1038S-16-N-125			
1 1/4"	IB1038S-15-N-180	180	37	883
1 1/2"	IB1038S-16-N-180			
1 1/4"	IB1038S-15-N-250	250	37	883
1 1/2"	IB1038S-16-N-250			



1031



1032



1033



1034



1041



1042



1044
&
1038S

Helpful Selection Information

Select a model with a higher maximum operating pressure (PMO) that meet or exceed the maximum steam pressure or the trap may not open. For example, the **IB-1032-14-N-250** has a PMO of 250 PSI. Choose a model that will handle the capacity requirement based on the differential pressure across the trap. Reference capacity charts.

CAPACITIES – Condensate (lbs/hr)																					
Model	Pipe Size	Orifice Size	PMO (PSIG)	Differential Pressure (PSI)																	
				1/4	1/2	1	2	5	10	15	20	30	50	60	70	80	100	125	150	180	200
1031 1041 1031S*	1/2", 3/4"	3/16"	20	139	200	270	340	450	560	640	690										
	1/2", 3/4"	1/8"	80	75	115	150	190	300	350	400	440	500	580	635	660	690					
	1/2", 3/4"	7/64"	125	50	80	100	145	240	280	320	350	410	490	520	560	580	640	680			
	1/2", 3/4"	#38	150	35	50	75	105	150	250	280	300	350	400	420	450	470	500	550	570		
1032	1/2", 3/4", 1"	1/4"	15	191	300	450	590	830	950	1060											
	1/2", 3/4", 1"	3/16"	30	150	235	325	410	530	700	820	880	1000									
	1/2", 3/4", 1"	5/32"	70	85	145	220	275	380	500	560	620	710	840	900	950						
	1/2", 3/4", 1"	1/8"	125	70	110	160	210	285	375	440	485	560	670	720	780	800	860	950			
	1/2", 3/4", 1"	7/64"	200	45	75	110	145	205	265	315	350	410	500	550	580	620	650	700	810	840	860
	1/2", 3/4", 1"	#38	250	15	40	80	105	155	205	240	270	320	400	500	530	550	580	630	660	690	710
1042	1/2", 3/4"	1/4"	15	191	300	450	590	830	950	1060											
	1/2", 3/4"	3/16"	30	150	235	325	410	530	700	820	880	1000									
	1/2", 3/4"	5/32"	70	85	145	220	275	380	500	560	620	710	840	900	950						
	1/2", 3/4"	1/8"	125	70	110	160	210	285	375	440	485	560	670	720	780	800	860	950			
	1/2", 3/4"	7/64"	200	45	75	110	145	205	265	315	350	410	500	550	580	620	650	700	810	840	860
	1/2", 3/4"	#38	250	15	40	80	105	155	205	240	270	320	400	500	530	550	580	630	660	690	710
1033	1/2", 3/4"	5/16"	15	350	570	850	1140	1600	1900	2100											
	1/2", 3/4"	1/4"	30	270	400	640	810	1000	1300	1600	1800	2050									
	1/2", 3/4"	3/16"	70	195	300	480	610	750	950	1200	1375	1600	1900	2000	2200						
	1/2", 3/4"	5/32"	125	130	205	320	415	595	775	910	900	1100	1380	1480	1600	1650	1800	2000			
	1/2", 3/4"	1/8"	200	75	120	200	255	365	490	585	630	700	900	980	1080	1120	1220	1400	1500	1560	1600
	1/2", 3/4"	7/64"	250	30	80	130	170	250	335	400	470	525	665	600	700	800	900	1000	1100	1180	1220
1034 1044	3/4", 1"	1/2"	15	950	1410	1880	2300	2900	3500	3900											
	3/4", 1"	3/8"	30	600	960	1300	1640	2200	2800	3300	3500	4000									
	3/4", 1"	5/16"	60	490	800	1090	1400	1750	2200	2600	2900	3500	4100	4400							
	3/4", 1"	9/32"	80	330	580	720	1070	1450	1800	2100	2400	2800	3300	3600	3800	4000					
	3/4", 1"	1/4"	125	260	430	620	810	1150	1650	1800	1900	2200	2600	2800	3000	3200	3600	3900			
	3/4", 1"	7/32"	180	200	310	470	610	880	1170	1380	1510	1800	2100	2300	2500	2700	2900	3200	3500	3700	
	3/4", 1"	3/16"	250	170	250	380	490	700	940	1100	1250	1450	1700	1800	2000	2100	2300	2700	2800	3100	3200
1038S	1 1/4", 1 1/2"	1/2"	15	1188	1763	2350	2875	3625	4375	4875											
	1 1/4", 1 1/2"	3/8"	30	760	1190	1625	2050	2750	3500	4125	4375	5125									
	1 1/4", 1 1/2"	5/16"	60	615	1000	1375	1750	2188	2750	3250	3625	4375	5125	5500							
	1 1/4", 1 1/2"	9/32"	80	420	720	900	1340	1810	2250	2625	3000	3500	4125	4500	4750	5000					
	1 1/4", 1 1/2"	1/4"	125	330	540	775	1010	1440	2063	2250	2375	2750	3250	3500	3750	4000	4500	4875			
	1 1/4", 1 1/2"	7/32"	180	250	390	590	760	1100	1470	1725	1890	2063	2375	2875	3125	3375	3625	4000	4375	4625	
	1 1/4", 1 1/2"	3/16"	250	210	320	470	610	875	1170	1380	1560	1800	2125	2250	2500	2625	2875	3375	3500	3875	4000

* 1031S only available @ PMO = 125 PSIG.



Replacement Kits

A replacement kit containing the lever and seat assembly is a more economical option than replacing the entire steam trap. Also available are replacement screens, gaskets and buckets.

When ordering replacement lever and seat assemblies specify model and operating pressure. See Replacement Parts and Kits Section for exact cross-reference to Armstrong PCA (Pressure Change Assembly) Kits.

Why use a Check Valve Option ?

The optional internal check valve allows the bucket trap to retain its prime even when exposed to superheated steam. The IB Trap must retain hot condensate inside the trap body to operate. Superheated steam or a sudden drop in inlet pressure can flash off the hot condensate inside the trap body causing the trap to lose its prime. If the steam pressure falls below the discharge pressure on the outlet side of the steam trap, the internal check valve will stop the back flow of condensate into the steam system. When discharging to a condensate return line, a check valve is always recommended.

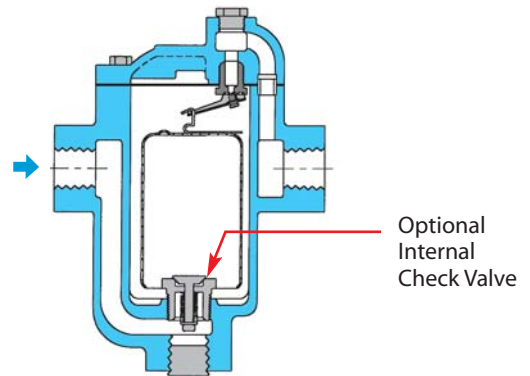

Steam Trap Installed Above Condensate Collection Point

In this example, condensate must travel upwards to reach the trap. Under this condition, it is possible for condensate to flow from the condensate return line into the steam coils, thereby flooding the system. The internal check valve, inside the IB trap, prevents the back flow of condensate.

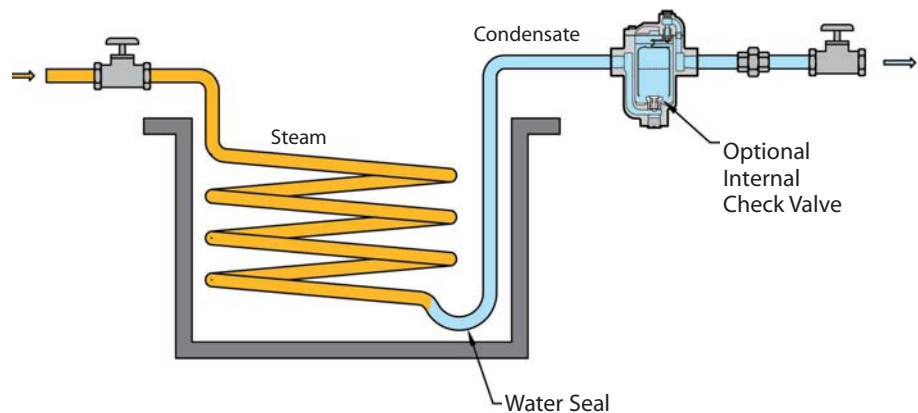

Steam Trap Discharging into Elevated Condensate Return Line

When a steam trap discharges condensate to an elevated location, a check valve should be used to stop condensate from flowing backwards into the steam system.

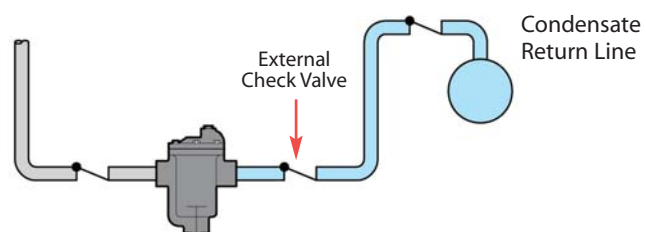

Why use a Thermic Vent ?

The Thermic Vent is used for discharging air from the steam system during start-up.

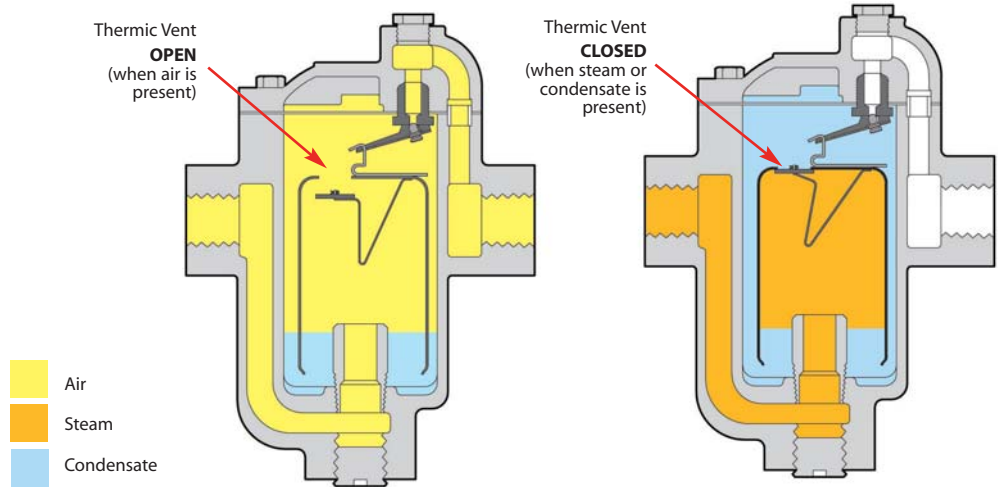

Blowdown Valve Connection

A Blowdown Valve connection is available as an option on the **1041, 1042, 1044, and 1038S** models. This simplifies maintenance by allowing the strainer to be cleaned without removal. User to supply blowdown valve.

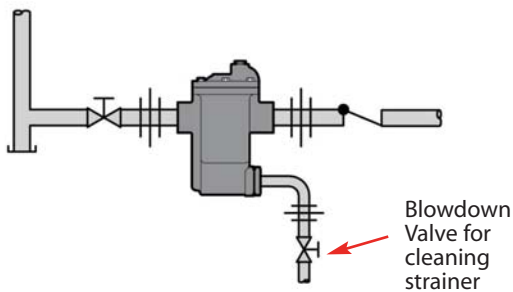
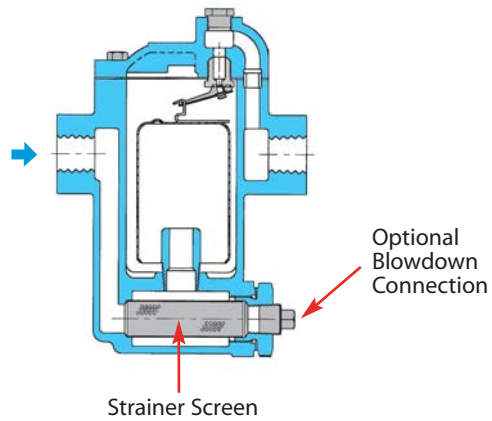

1031S

The **1031S** is equipped with a small protection screen to guard against dirt in the steam system. It is a more economical alternative than the 1041 which has a full-port strainer. Specifically designed for use in laundries. Available in 125 PSIG model only.

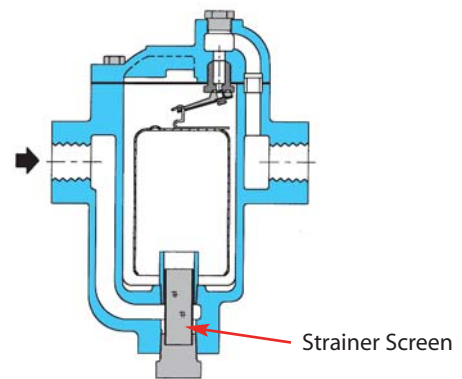

UC450 Series

Quick-Change Universal Style Trap-Connector System

The **UC450 Series QUICK-CHANGE Universal Trap-Connector System** with multiple choices for trap modules and multiple choices for connectors are used in steam systems where a simplified and economical maintenance program of steam traps is desired. These Universal Style quick replacement steam traps can be used on steam supply lines as well as for tracing and small process applications. They are commonly used in chemical plants, petrochemical refineries, paper mills and other industrial facilities.

The All Stainless Steel Universal Style Steam Traps feature a permanent installation of the Universal Connector with a 2-bolt mounting arrangement for the Universal Steam Trap Module, allowing the Steam Trap to be removed and replaced in minutes:

- Steam trap is replaced without having to unthread piping
- By removing only 2 bolts with a socket or open-end wrench
- Trap module can swivel 360° on the universal connector allowing proper orientation

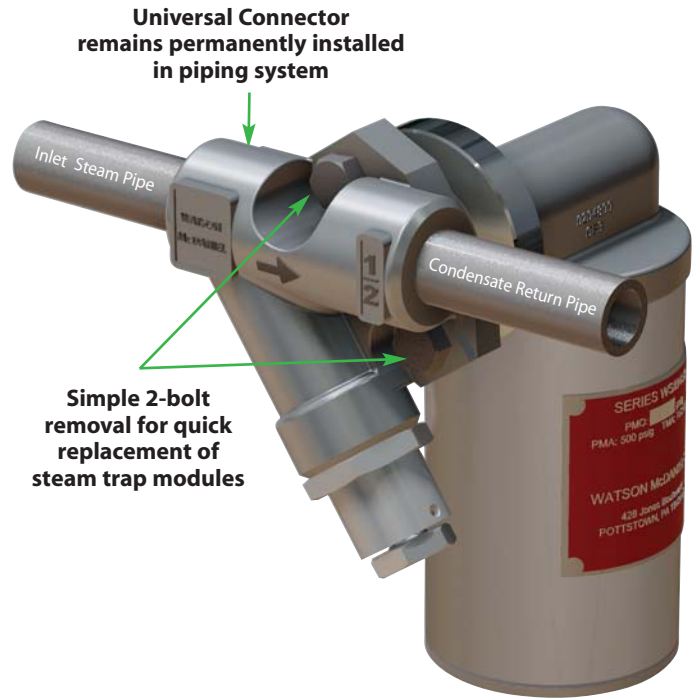

“QUICK-CHANGE” Universal Trap Modules

STEP 1:
Select an appropriate Universal **STEAM TRAP MODULE**



UTD450
Thermodynamic
"Top Mount"



UTD450SM
Thermodynamic
"Side Mount"



UT450
Thermostatic
Bellows



UB450
Thermostatic
Adjustable Bi-Metal



USIB450
Inverted
Bucket



UFT450
Float &
Thermostatic

“QUICK-CHANGE” Universal Connectors

STEP 2:
Select appropriate Universal **CONNECTOR**. Any Universal Connector (shown right) will work with any Universal Steam Trap Module. (Including those of other manufacturers. See product catalog for full offering of Connectors.) Trap orientation must be considered.



UC450

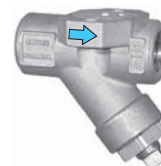

UC450S

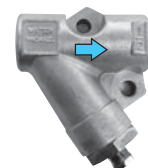

UC450SR

Why Use the UC450 Series "QUICK-CHANGE" Universal Style Trap-Connector System ?

Quick-Change Steam Traps are recommended in any application – particularly those which require simple and frequent replacement of steam traps

Universal Connectors These Connectors remain permanently installed in the piping system. The convenient 2-bolt mounting system allows the Trap Module to be replaced quickly and easily using a socket or open-end wrench without having to unthread piping.

Quick-Change Steam Trap Modules with Universal Connectors

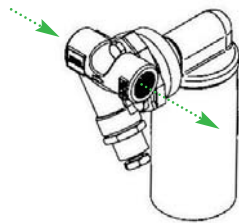

Inverted Bucket Trap

USIB450 Steam Trap
(shown with)
UC450S Connector

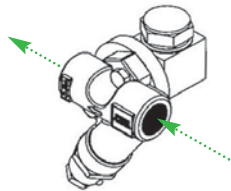

Thermodynamic "side-mount" Trap

UTD450SM Steam Trap
(shown with)
UC450SBL Connector

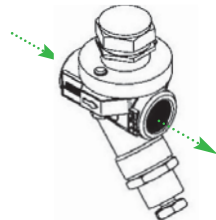

Thermodynamic "top-mount" Trap

UTD450 Steam Trap
(shown with)
UC450SB Connector

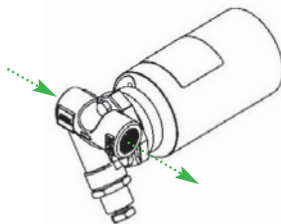

Float & Thermostatic Trap

UFT450 Steam Trap
(shown with)
UC450SBR Connector

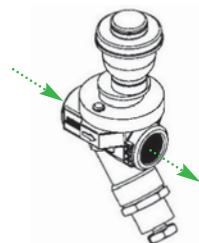

Thermostatic Trap

UT450 Steam Trap
(shown with)
UC450SB Connector

4 basic configurations of connectors are available:
UC450, UC450S & UC450R/
UC450L.

Choice is based on strainer orientation or if a piping interference exists.

The UC450SR is the standard connector choice. The R & L versions are a mirror image of each other and are strictly a user's preference based on piping orientation.



UC450

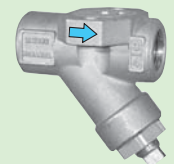

UC450S

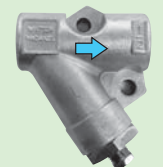

UC450SR

UC450 Series

Universal Style Quick-Change Connectors

(For use with Universal Quick-Change Trap Modules)

Model	UC450, UC450S, UC450SB UC450SR, UC450SBR, UC450SL, UC450SBL
Sizes	1/2", 3/4", 1"
Connections	NPT, SW, FLG
Body Material	Stainless Steel
PMO Max. Operating Pressure	(trap module dependent)
TMO Max. Operating Temperature	(trap module dependent)
PMA Max. Allowable Pressure	750 PSIG @ 100°F
TMA Max. Allowable Temperature	800°F @ 400 PSIG

Steam Trap Modules that mount to Universal Connectors are shown on the following pages. Trap modules available in: Inverted Bucket, Float & Thermostatic, Thermodynamic, Thermostatic and Bi-metallic type.

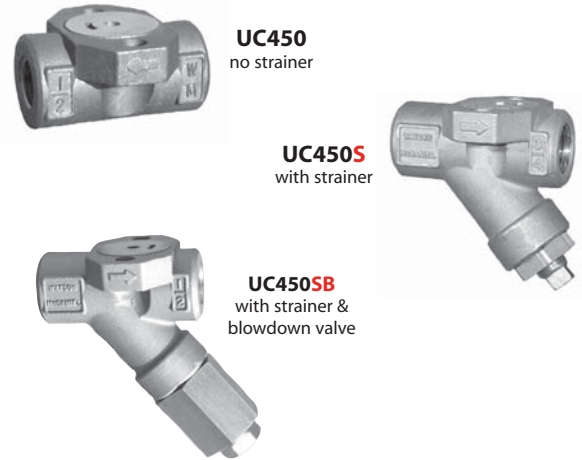

Typical Applications

DRIP, TRACER: UC450 Series Universal Trap Connectors reduce the time and manpower to replace steam traps. The stainless steel Connector remains permanently in-line allowing steam trap module to be replaced in minutes. These universal connectors can be used for drip service on steam mains and steam supply lines, tracing, or for small process equipment. Industrial standard 2-bolt universal connectors are commonly used in chemical plants, petrochemical refineries, paper mills, and other industrial facilities. The UC450 connectors conform to industrial standards, making them compatible with other manufacturers' universal steam trap modules.

Used with the following Watson McDaniel Steam Trap Modules:

USIB450	- Inverted Bucket
UTD450	- Thermodynamic
UTD450SM	- Thermodynamic
UTD600LSM	- Thermodynamic
UT450	- Thermostatic
UFT450	- Float & Thermostatic
UB450	- Bi-Metallic

How It Works

Universal connectors remain permanently installed in the piping system. The convenient 2-bolt mounting system allows the trap module to be removed and replaced quickly and easily using a socket or open-end wrench without disturbing the existing piping.

Features

- Universal connector with 2-bolt mounting allows for fast, easy replacement of trap module making it more cost-effective than replacing conventional type steam traps
- All stainless steel construction
- Trap module can rotate 360° on the universal connector allowing any orientation during installation
- Compatible with other manufacturers' trap modules
- Available with integral strainer and blowdown valve

Sample Specification

The Universal Connector shall be all stainless steel construction with a two-bolt 360 degree swivel mount flange design and available with integral strainer and blowdown valve.

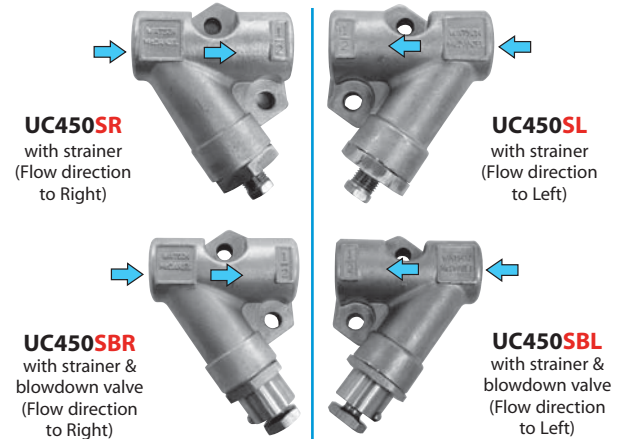

Note: Optional Flanged units available.

Installation and Maintenance

The universal connector can be installed in vertical or horizontal piping and available in 1/2", 3/4" and 1" threaded NPT and socket weld (SW). In horizontal installations, orientation of connector body may be dependent on the specific type of trap module used. These connectors remain permanently installed in the piping system. The convenient 2-bolt mounting system allows the trap module to be easily replaced using a socket or open-end wrench without having to unthread piping.

MATERIALS

Body	Stainless Steel, AISI 316
Strainer	40 Mesh Stainless Steel, AISI 304
Blowdown Valve	Stainless Steel, AISI 303

How to Size / Order

Connectors and Trap Modules are ordered separately. See following pages for the Trap Modules.

UC450 Series

Universal Style Quick-Change Connectors

(For use with Universal Quick-Change Trap Modules)

Helpful Selection Information
 Choose the desired style connector:
 UC450, UC450S
 UC450SR (flow to right)
 UC450SL (flow to left)

Four basic configurations of connectors are available: UC450, UC450S, and UC450SR/UC450SL. The UC450SR (with strainer, flow to right) is the most common connector choice. Choice is based upon strainer orientation or if a piping interference exists. All connector styles operate with any trap module. The **R** and **L** versions are mirror images of each other and are selected based on which side the user prefers the trap mounted on.

UC450 Type

UC450
No Strainer



Size	Model Code Threaded - NPT	Model Code Socket Weld	Weight lbs
Connector			
1/2"	UC450-12-N	UC450-12-SW	1.5
3/4"	UC450-13-N	UC450-13-SW	1.5
1"	UC450-14-N	UC450-14-SW	3.0

UC450S Type

UC450S
Strainer

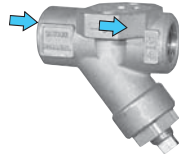

UC450SB
Strainer & Blowdown Valve

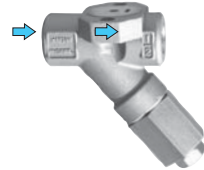

Size	Model Code Threaded - NPT	Model Code Socket Weld	Weight lbs
Connector (with Strainer)			
1/2"	UC450S-12-N	UC450S-12-SW	2.5
3/4"	UC450S-13-N	UC450S-13-SW	2.5
1"	UC450S-14-N	UC450S-14-SW	3.5
Connector (with Strainer & Blowdown Valve)			
1/2"	UC450SB-12-N	UC450SB-12-SW	2.5
3/4"	UC450SB-13-N	UC450SB-13-SW	2.5
1"	UC450SB-14-N	UC450SB-14-SW	4.5

UC450SR Type

Flow to Right (as viewed)

UC450SR
Strainer

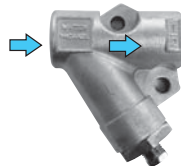

UC450SBR
Strainer & Blowdown Valve

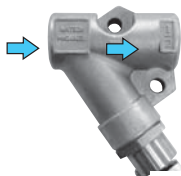

Size	Model Code Threaded - NPT	Model Code Socket Weld	Weight lbs
Connector (with Strainer) FLOW TO RIGHT			
1/2"	UC450SR-12-N	UC450SR-12-SW	2.5
3/4"	UC450SR-13-N	UC450SR-13-SW	2.5
1"	UC450SR-14-N	UC450SR-14-SW	2.5
Connector (with Strainer & Blowdown Valve) FLOW TO RIGHT			
1/2"	UC450SBR-12-N	UC450SBR-12-SW	2.5
3/4"	UC450SBR-13-N	UC450SBR-13-SW	2.5
1"	UC450SBR-14-N	UC450SBR-14-SW	2.5

UC450SL Type

Flow to Left (as viewed)

UC450SL
Strainer

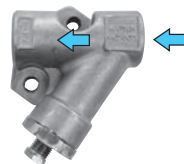

UC450SBL
Strainer & Blowdown Valve

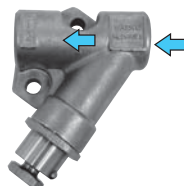

Size	Model Code Threaded - NPT	Model Code Socket Weld	Weight lbs
Connector (with Strainer) FLOW TO LEFT			
1/2"	UC450SL-12-N	UC450SL-12-SW	2.5
3/4"	UC450SL-13-N	UC450SL-13-SW	2.5
1"	UC450SL-14-N	UC450SL-14-SW	2.5
Connector (with Strainer & Blowdown Valve) FLOW TO LEFT			
1/2"	UC450SBL-12-N	UC450SBL-12-SW	2.5
3/4"	UC450SBL-13-N	UC450SBL-13-SW	2.5
1"	UC450SBL-14-N	UC450SBL-14-SW	.5

UC450, UC450S, UC450SB Universal Connectors

Connectors available in 1/2", 3/4" and 1" sizes in NPT or Socket-Weld Connections

Note: Optional Flange units available.

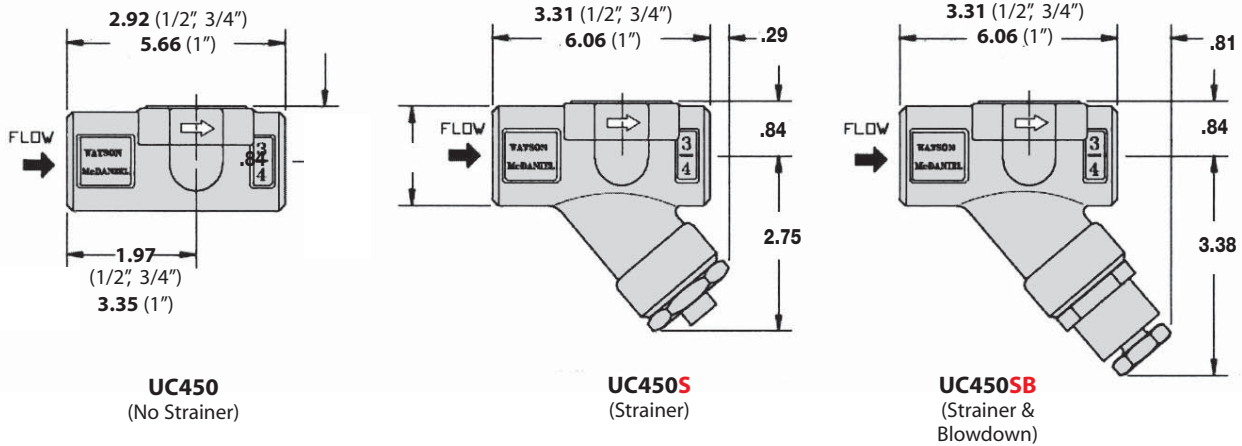

UC450SR & UC450SBR Universal Connectors

Connectors available in 1/2", 3/4" and 1" sizes in NPT or Socket-Weld Connections

Flow Direction - To RIGHT

Note: Optional Flange units available.

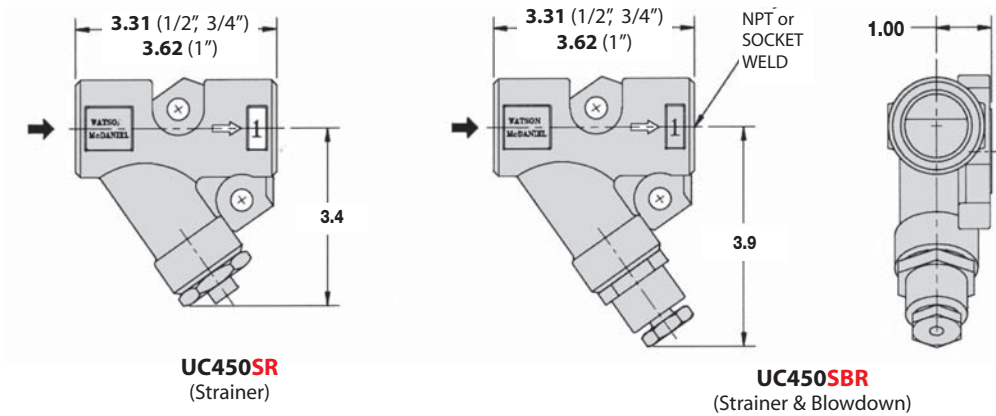

UC450SL & UC450SBL Universal Connectors

Connectors available in 1/2", 3/4" and 1" sizes in NPT or Socket-Weld Connections

Flow Direction - To LEFT

Note: Optional Flange units available.

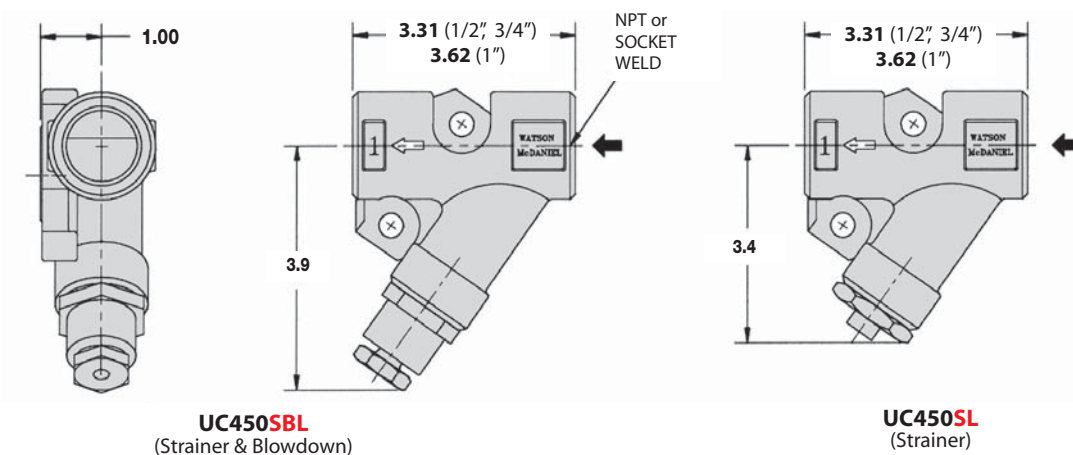

UC450SBR
Connector



USIB450
Trap Module

UTD450
Trap Module

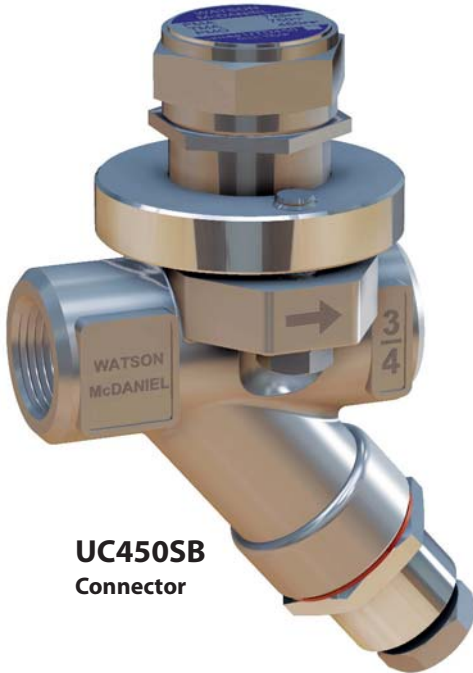

UC450SB
Connector

UC450SL
Connector



UT450
Trap Module

UC450SBL
Connector

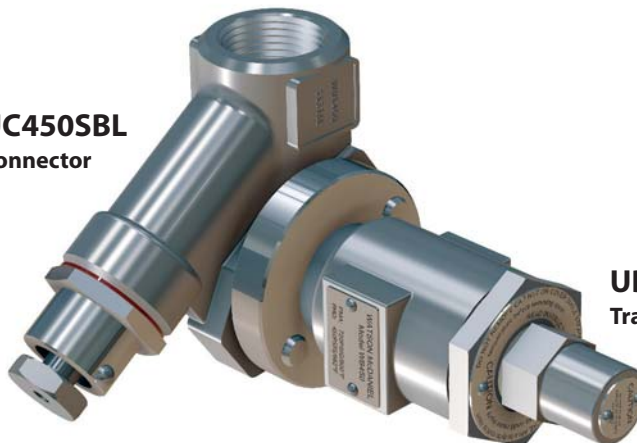

UB450
Trap Module

USIB450

Universal Style Quick-Change Trap Module

Inverted Bucket Steam Trap Module (mounts to UC450 Universal Connectors)

Model	USIB450, USIB450H
Connections	Fits UC450 Series Universal Connectors
Body Material	Stainless Steel
PMO Max. Operating Pressure	450 PSIG*
TMO Max. Operating Temperature	800°F
PMA Max. Allowable Pressure	720 PSIG @ 100°F
TMA Max. Allowable Temperature	800°F @ 400 PSIG

*750°F @ operating pressures below 400 PSIG. See installation note regarding using trap in superheated applications.



Steam trap modules can be used with other manufacturers' Universal Connectors.

Typical Applications

DRIP, TRACER: The **USIB450** inverted bucket steam trap modules must be mounted to a universal connector. They are typically used for drip applications such as draining condensate from steam mains or steam supply lines as well as for steam tracing applications. **USIB450H** is the higher capacity model.

How It Works

The UC450 universal connector is permanently installed into the pipeline where the steam trap would normally be placed. The trap module, which functions like any standard inverted bucket steam trap, is fastened to the universal connector with two bolts. When a new trap module is needed, it can be easily removed and replaced with a standard open-end or socket wrench without disturbing the existing piping.

Sample Specification

The steam trap shall be an all stainless steel modular design, inverted bucket type with a frictionless valve lever assembly. The trap shall have a 360 degree swivel mount on a stainless steel Universal Connector that is available with integral strainer and blowdown valve options.

Options

Universal Connectors are available with an integral strainer and blowdown valve. Connector is purchased separately. See the UC450 Universal Connectors section for more information.

Installation and Maintenance

Universal connector is first permanently threaded or welded into piping system. The USIB trap module is attached to the universal connector with two bolts. When a new trap is needed, it can be easily removed and replaced with a standard open-end or socket wrench without disturbing the existing piping. Trap must be installed in upright position as shown to function properly. With superheated steam, a check valve must be installed at inlet of trap to prevent the loss of prime. In vertical piping installations with upward flow, use of a blowdown valve is not recommended because discharge would be in upward and possibly unsafe direction.

Features

- Trap module can be easily removed and replaced in minutes without having to disconnect any piping
- Hardened stainless steel valves and seat
- Freeze resistant
- Connectors available with integral strainers and blowdown valves
- 360° swivel design for convenient installation

MATERIALS

Body	Stainless Steel GR CF3
Cover	304L Stainless Steel
Internals	300 Series Stainless Steel
Valve Plug & Seat	420F Stainless Steel
Bolts	ASTM A193 GR B7
Gasket	Spiral-Wound 304 Stainless Steel with Grafoil Filler
Swivel Flange	303 Stainless Steel

CAPACITIES – Condensate (lbs/hr)

Model	Orifice Size	PMO (PSIG)	Differential Pressure (PSI)																			
			5	10	15	20	25	30	40	50	60	70	80	100	125	150	180	200	250	350	450	
USIB450-20	3/16"	20	450	560	640	690																
USIB450-80	1/8"	80	300	350	400	440	460	500	550	580	635	660	690									
USIB450-150	#38	150	210	250	280	300	320	350	380	400	420	450	470	500	550	570						
USIB450-450	.057	450	31	50	70	84	95	105	120	133	145	152	160	174	187	198	208	215	228	248	263	
USIB450H-15	1/4"	15	830	950	1060																	
USIB450H-30	3/16"	30	530	700	820	880	950	1000														
USIB450H-70	5/32"	70	380	500	560	620	680	710	770	840	900	950										
USIB450H-125	1/8"	125	285	375	440	485	530	560	620	670	720	780	800	860	950							
USIB450H-200	7/64"	200	205	265	315	350	385	410	465	500	580	590	620	650	700	810	840	860				
USIB450H-250	#38	250	155	205	240	270	295	320	360	400	500	530	550	580	630	660	690	710	760			
USIB450H-450	.057	450	31	50	70	84	95	105	120	133	145	152	160	174	187	198	208	215	228	248	263	

USIB450

Inverted Bucket Steam Trap Module (mounts to UC450 Universal Connectors)

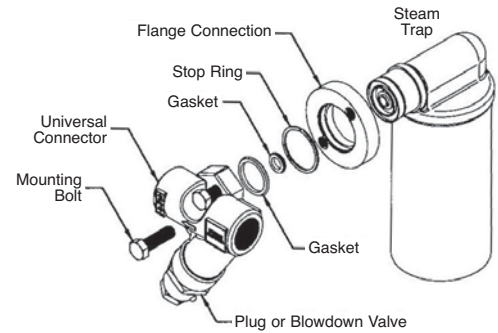
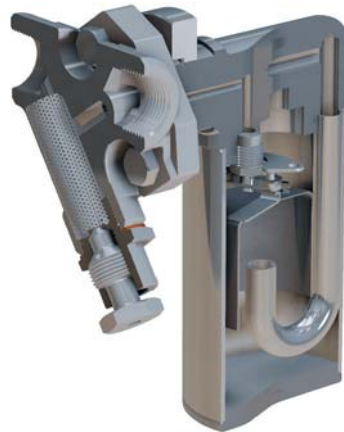

Horizontal Piping (Connector with Strainer)	Vertical Piping (Connector with Strainer)	Vertical or Horizontal Piping (No Strainer)
<p>Steam Flow to the Right (Standard)</p> <p>Trap shown with UC450SR Connector (Use L Style if a Piping Constraint exists)</p>	<p>Steam Flow Downward</p> <p>Trap shown with UC450SR Connector</p>	<p>Steam Flow Any Direction</p> <p>Trap shown with UC450 Connector</p>

Connectors available in 1/2", 3/4" and 1" sizes in NPT or Socket-Weld Connections

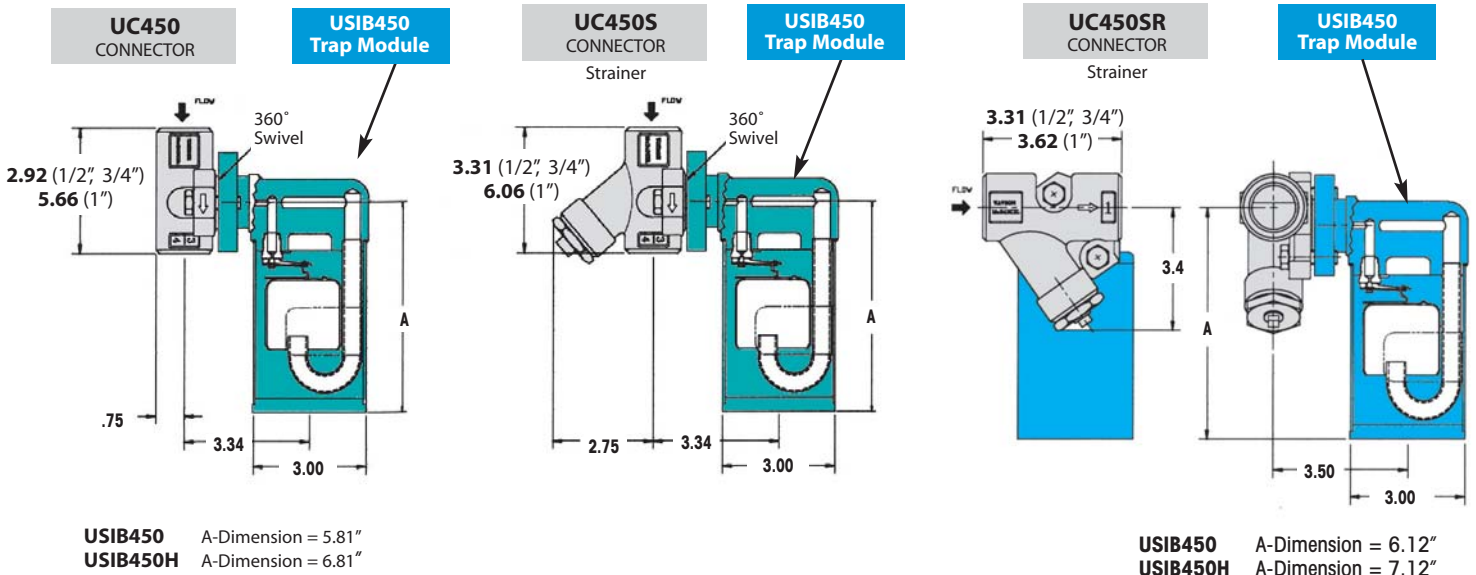

UFT450

Universal Style Quick-Change Trap Module

Float & Thermostatic Steam Trap Module (mounts to UC450 Universal Connectors)

Model	UFT450
Connections	Fits UC450 Series Universal Connectors
Body Material	Stainless Steel
PMO Max. Operating Pressure	225 PSIG
TMO Max. Operating Temperature	397°F
PMA Max. Allowable Pressure	720 PSIG @ 100°F
TMA Max. Allowable Temperature	800°F @ 400 PSIG



UFT450
Float & Thermostatic
Steam Trap Module

Steam trap modules **can be used with other manufacturers' Universal Connectors.**

Typical Applications

PROCESS, DRIP: The **UFT450** Float & Thermostatic steam trap module can be used on small process equipment which generate light condensate loads. F&T traps have excellent air handling capability. These F&T trap modules can also be used in drip service on steam mains and steam supply lines. Mounts to any universal connector.

How It Works

The UC450 universal connector is permanently installed into the pipeline where the steam trap would normally be placed. The trap module, which functions like any F&T steam trap, is fastened to the universal connector with two bolts. When a new trap module is needed, it can be easily removed and replaced with a standard open-end or socket wrench without disturbing the existing piping.

Sample Specification

The steam trap shall be an all stainless steel modular design, float & thermostatic unit. The thermostatic air vent to be pressure balanced welded bellows. The trap shall have a 360 degree swivel mount on a stainless steel Universal Connector that is available with integral strainer and blowdown valve options.

Installation and Maintenance

Universal connector is first permanently threaded or welded into piping system. The UFT450 mounts to any 2-Bolt Quick-Change Universal Connector. Trap module must be installed in orientation shown. The trap module is bolted to the universal connector with two bolts. When a new trap module is needed, it can be easily removed and replaced with a standard open-end or socket wrench without disturbing the existing piping.

Features

- Trap module can be easily removed and replaced in minutes without having to disconnect any piping
- Hardened stainless steel valves and seat
- Freeze-resistant
- Connectors available with integral strainers and blowdown valves
- 360° swivel design for convenient installation

Options

Universal Connectors are available with an integral strainer and blowdown valve. Connector is purchased separately. See the Universal Connectors section for more information.

Helpful Selection Information

Select a model with a PMO (maximum operating pressure) that meets or exceeds the steam pressure of the system. For example, the UFT450-65 has a maximum operating pressure of 65 PSI. Any universal connector can be used. Recommended connector: UC450SR

MATERIALS

Body	Stainless Steel GR CF3
Cover	304L Stainless Steel
Internals	300 Series Stainless Steel
Valve Disc	420F Stainless Steel
Valve Seat	17-4 PH Stainless Steel
Bolts	ASTM A193 GR B7
Gasket	Spiral-Wound 304 Stainless Steel with Grafoil Filler
Swivel Flange	303 Stainless Steel

CAPACITIES — Condensate (lbs/hr)

Model	PMO (PSIG)	Differential Pressure (PSI)																		
		1/4	1/2	1	2	5	10	15	20	30	40	50	65	75	100	125	145	200	225	
UFT450-15	15	390	490	620	780	1050	1320	1500												
UFT450-65	65	115	155	205	270	390	520	610	685	810	910	995	1110							
UFT450-145	145	55	75	100	135	200	270	320	365	435	490	540	600	640	725	795	850			
UFT450-225	225	40	50	70	95	135	185	220	245	290	330	360	405	430	485	530	565	645	680	

UFT450

Universal Style Quick-Change Trap Module

Universal Style

Float & Thermostatic Steam Trap Module (mounts to UC450 Universal Connectors)



UFT450 Trap Module must be oriented Horizontally, as shown.

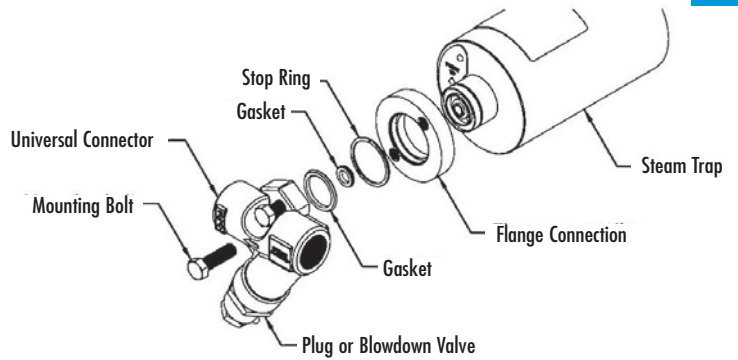

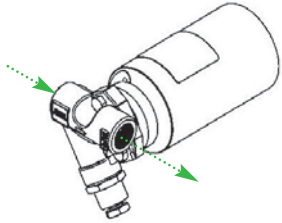
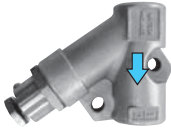
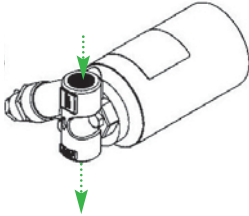
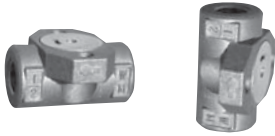
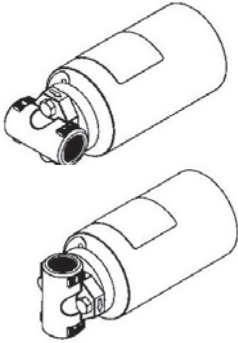
Horizontal Piping (Connector with Strainer)	Vertical Piping (Connector with Strainer)	Vertical or Horizontal Piping (No Strainer)
<p>Steam Flow to the Right UC450SBR Connector (with Blowdown Valve) shown below</p>  <p>Trap shown with UC450SBR Connector (Use L Style Connector to reverse orientation as an alternative if a Piping Constraint exists)</p> 	<p>Steam Flow Downward UC450SBR Connector (with Blowdown Valve) shown below</p>  <p>Trap shown with UC450SBR Connector</p> 	<p>Steam Flow Any Direction UC450 Connector shown below</p>  <p>Trap shown with UC450 Connector</p> 

Connectors available in 1/2", 3/4" and 1" sizes in NPT or Socket-Weld Connections

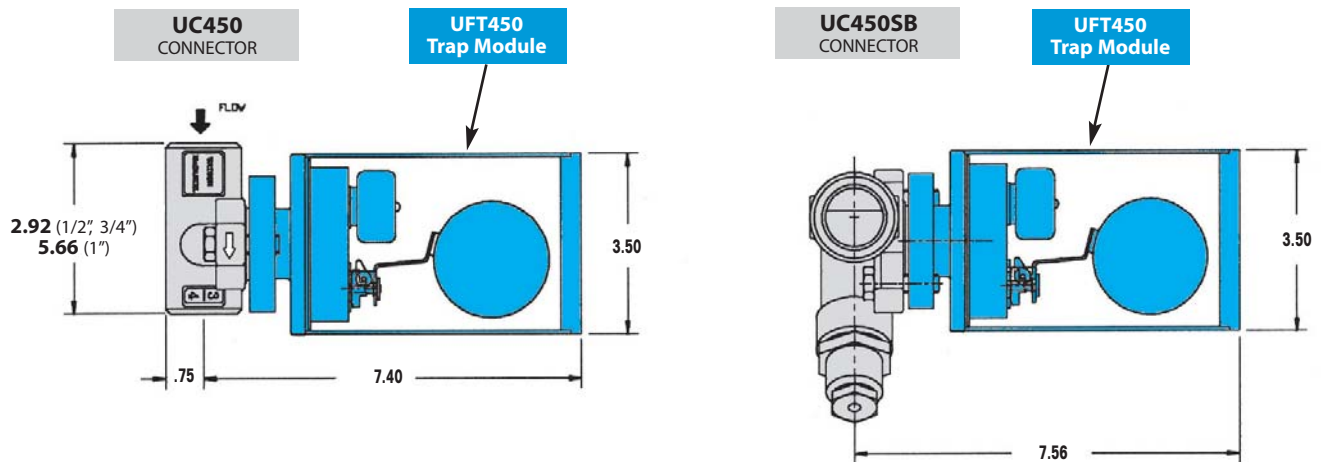

UTD450 UTD600

Universal Style Quick-Change Trap Module

Thermodynamic Steam Trap Module (mounts to UC450 Universal Connectors)

Model (Side Mount Style)	UTD450LSM UTD450SM	UTD600LSM
Connections	Fits UC450 Series Universal Connectors	
Body Material	Stainless Steel	Stainless Steel
PMO Max. Operating Pressure	450 PSIG	600 PSIG
TMO Max. Operating Temperature	750°F	750°F
PMA Max. Allowable Pressure	720 PSIG @ 100°F	720 PSIG @ 100°F
TMA Max. Allowable Temperature	800°F @ 400 PSIG	800°F @ 600 PSIG



**UTD450
&
UTD600**
**Thermodynamic
Steam Trap Module**
(Side Mount Style)
For vertical or horizontal
piping installations.

Steam trap modules can be used with other manufacturers' Universal Connectors.

Typical Applications

DRIP, TRACER: Designed for drip applications for the draining of condensate from steam mains and other steam supply lines as well as for tracing applications. The **UTD450 & UTD600** Steam Trap Modules can be used anywhere conventional thermodynamic steam traps are used. This trap module can be used on either vertical or horizontal piping installations and can mount to any 2-bolt Quick-Change Universal Connector.

How It Works

The UC450 universal connector is permanently installed into the pipeline where the steam trap would normally be placed. The trap module, which functions like any thermodynamic steam trap, is fastened to the universal connector with two bolts. When a new trap module is needed, it can be easily removed and replaced with a standard open-end or socket wrench without disturbing the existing piping.

Features

- Trap module can be easily removed and replaced in minutes without having to disconnect any piping
- Trap modules can be used with most manufacturers' 2-bolt universal connector
- All stainless steel construction with hardened seat

Sample Specification

The steam trap module shall be designed to attach to the industry standard two-bolt universal connector. Trap module shall be of a thermodynamic design. Universal connector shall conform to the two bolt industry standard with integral strainer and blowdown options.

Installation and Maintenance

Universal connector is first permanently installed (threaded, welded, flanged) into piping system. Trap module should be installed in orientation shown with cap facing upwards. The trap module is fastened to the universal connector using two bolts. If the trap fails for any reason, replace only the trap module. In vertical piping installations with upward flow, use of a blowdown valve is not recommended. Discharge would be in upward and unsafe direction.

Options

Universal Connectors are available with an integral strainer and blowdown valve. Connector is purchased separately. See the Universal Connectors section for more information.

Helpful Selection Information

Connector selection to use with the UTD450SM and UTD600LSM: UC450 (no strainer), UC450SR (strainer), UC450SBR (strainer and blowdown).

MATERIALS

Body	Stainless Steel, AISI 420
Disc	Stainless Steel, AISI 420
Cap	Stainless Steel, AISI 416
Insulation Cover	Stainless Steel, AISI 304
Bolts	Steel, ASTM A193 GR B7
Gaskets (2)	Spiral Wound 304 Stainless Steel with Grafoil Filler

CAPACITIES – Condensate (lbs/hr)

Model	Differential Pressure (PSI)																
	4	10	15	20	25	30	40	50	75	100	150	200	250	300	400	450	600
UTD450LSM	140	215	242	270	295	320	355	390	455	510	600	670	730	790	880	925	
UTD450SM	247	370	420	475	520	560	625	685	800	900	1060	1185	1300	1400	1560	1630	
UTD600LSM											465	500	550	600	632	675	730

UTD450 UTD600

Universal Style Quick-Change Trap Module

Thermodynamic Steam Trap Module (mounts to UC450 Universal Connectors)

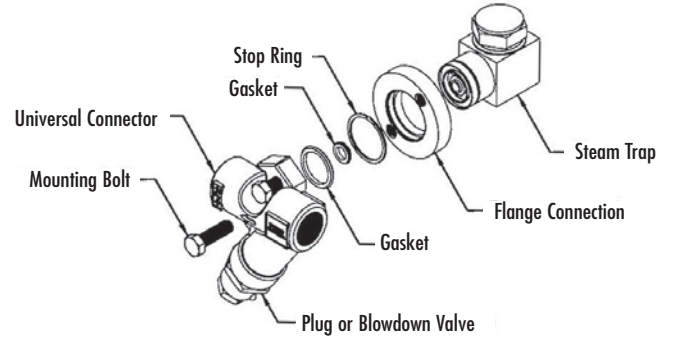

UTD450/UTD600 Trap Module should be oriented with cap facing Upwards, As shown.

Horizontal Piping (Connector with Strainer)	Vertical Piping (Connector with Strainer)	Vertical or Horizontal Piping (No Strainer)
<p>Steam Flow to the Right or to the Left</p> <p>Trap shown with UC450SBR Connector</p> <p>Trap shown with UC450SBL Connector</p>	<p>Steam Flow Downward</p> <p>Trap shown with UC450SBR Connector</p>	<p>Steam Flow Vertically or Horizontally</p> <p>Trap shown with UC450 Connector</p>

Connectors available in 1/2", 3/4" and 1" sizes in NPT and Socket-Weld Connections

UC450SR
CONNECTOR
Strainer

UC450SBR
CONNECTOR
Strainer & Blowdown

**UTD450SM
or
UTD600LSM
Steam Trap**

UC450SBL
CONNECTOR
Strainer & Blowdown

DIMENSIONS - inches			
Size	A	B	C
1/2"	3.31	3.25	3.78
3/4"	3.31	3.25	3.78
1"	3.62	3.44	3.95

UTD450

Quick-Change Trap Module

Thermodynamic Steam Trap Module (mounts to UC450 Universal Connectors)

Model (Top Mount Style)	UTD450 UTD450L
Connections	Fits UC450 Series Universal Connectors
Body Material	Stainless Steel
PMO Max. Operating Pressure	450 PSIG
TMO Max. Operating Temperature	750°F
PMA Max. Allowable Pressure	720 PSIG @ 100°F
TMA Max. Allowable Temperature	800°F @ 400 PSIG



UTD450
Thermodynamic Steam Trap Module
(Top Mount Style)
Recommended for horizontal piping installations only so that cap can be oriented upwards as shown.

Steam trap modules can be used with other manufacturers' Universal Connectors.

Typical Applications

DRIP, TRACER: Designed to work as a drip trap for the draining of condensate from steam mains and other steam supply lines, the **UTD450** Thermodynamic Steam Trap Module can be used anywhere conventional thermodynamic steam traps are used. Can also be used on tracing applications. This model is only recommended for horizontal piping installations to allow the cap to be oriented upwards. The UTD450 mounts to any 2-bolt Quick-Change Universal Connector.

The UTD450 is recommended for horizontal piping only so that cap can be oriented upwards, as shown.

How It Works

The UC450 universal connector is permanently installed into the pipeline where the steam trap would normally be placed. The trap module, which functions like any thermodynamic steam trap, is fastened to the universal connector with two bolts. When a new trap module is needed, it can be easily removed and replaced with a standard open-end or socket wrench without disturbing the existing piping.

Features

- Trap module can be easily removed and replaced in minutes without having to disconnect any piping
- Trap modules can be used with most manufacturers' 2-bolt universal connector
- All stainless steel construction with hardened seat

Sample Specification

The steam trap module shall be designed to attach to the industry standard two-bolt universal connector. Trap module shall be of a thermodynamic design. Universal connector shall conform to the two bolt industry standard with integral strainer and blowdown options.

Installation and Maintenance

The UTD450 Trap module was intended for horizontal piping installations so the trap can be installed with cap facing upwards. Trap module is attached to the connector using two bolts. If the trap fails for any reason, replace only the trap module. When a new trap module is needed, it can be easily removed and replaced with a standard open-end or socket wrench without disturbing the existing piping.

Options

Universal Connectors are available with an integral strainer and blowdown valve. Connector is purchased separately. See the Universal Connectors section for more information.

Helpful Selection Information

Connector selection to use with the UTD450: UC450 (no strainer), UC450S (strainer), UC450SB (strainer and blowdown). Select this model for steam systems with maximum working pressure of 450 PSIG.

MATERIALS

Body	Stainless Steel, AISI 420
Disc	Stainless Steel, AISI 420
Cap	Stainless Steel, AISI 416
Insulation Cover	Stainless Steel, AISI 304
Bolts	Steel, ASTM A193 GR B7
Gaskets (2)	Spiral Wound 304 Stainless Steel with Grafoil Filler

CAPACITIES – Condensate (lbs/hr)

Model	Differential Pressure (PSI)																
	4	10	15	20	25	30	40	50	75	100	150	200	250	300	350	400	450
UTD450L	140	215	242	270	295	320	355	390	455	510	600	670	730	790	840	880	925
UTD450	247	370	420	475	520	560	625	685	800	900	1060	1185	1300	1400	1485	1560	1630

UTD450

Universal Style Quick-Change Trap Module

Thermodynamic Steam Trap Module (mounts to UC450 Universal Connectors)

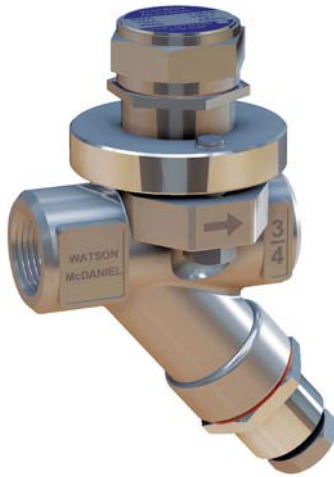

UTD450 Trap Module should be oriented with cap facing Upwards. Therefore it should only be used with Horizontal Piping, as shown.

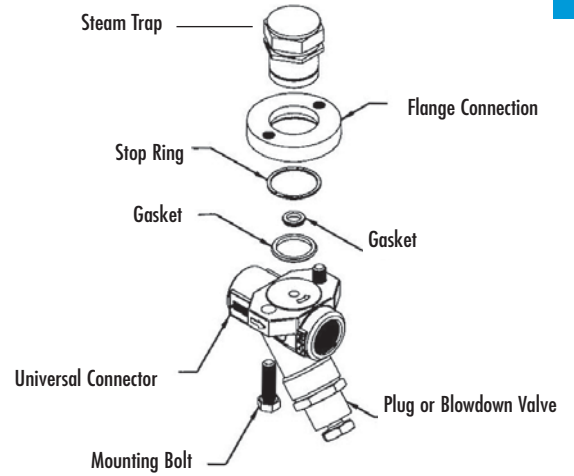

Horizontal Piping (Connector with Strainer)

Steam Flow to the Right or to the Left
UC450SBR & UC450SB Connector (with Blowdown Valve) shown below



Trap shown with **UC450SBR** Connector Strainer & Blowdown Valve is directed to the side

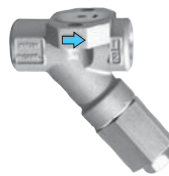

Trap shown with **UC450SB** Connector Strainer & Blowdown Valve is directed downwards

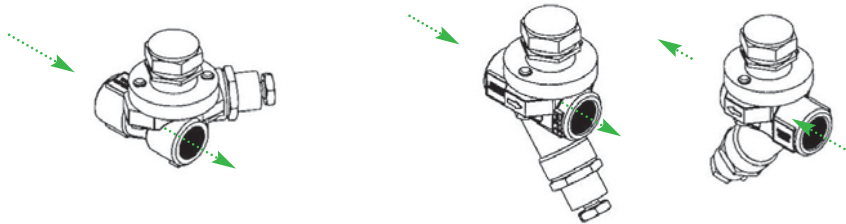

Horizontal Piping (No Strainer)

Steam Flow Horizontally
UC450 Connector shown below



Trap shown with **UC450** Connector

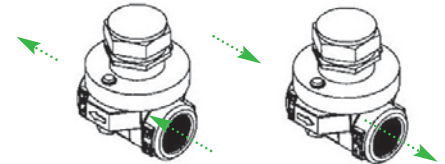

Connectors available in 1/2", 3/4" and 1" sizes in NPT and Socket-Weld Connections

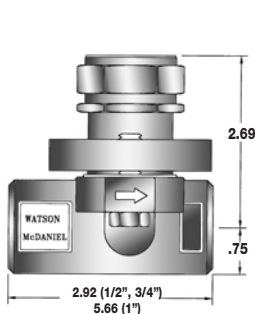

UTD450 Trap Module with UC450 Connector

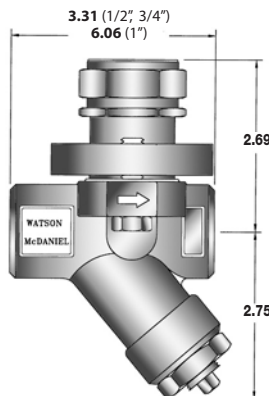

UTD450 Trap Module with UC450S Connector (Strainer)

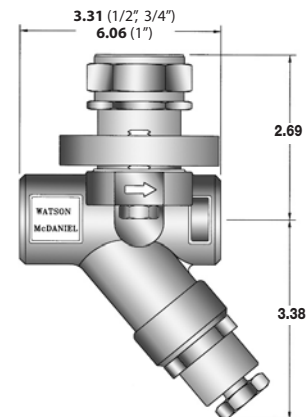

UTD450 Trap Module with UC450SB Connector (Strainer & Blowdown)

UT450

Universal Style Quick-Change Trap Module

Thermostatic Steam Trap Module (mounts to UC450 Universal Connectors)

Model	UT450
Connections	Fits UC450 Series Universal Connectors
Body Material	Stainless Steel
PMO Max. Operating Pressure	450 PSIG
TMO Max. Operating Temperature	Saturated Steam Temp.
PMA Max. Allowable Pressure	720 PSIG @ 100°F
TMA Max. Allowable Temperature	800°F @ 400 PSIG

Steam trap modules can be used with other manufacturers' Universal Connectors.



UT450
Thermostatic
Steam Trap
Module

Typical Applications

DRIP, TRACER, PROCESS: The **UT450** Thermostatic Steam Trap Module can be used anywhere conventional thermostatic steam traps are used. Used for drip, tracing and light process applications. Trap module mounts to any 2-bolt Quick-Change Universal Connector.

How It Works

The UC450 universal connector is permanently installed into the pipeline where the steam trap would normally be placed. The trap module is fastened to the universal connector with two bolts. When a new trap module is needed, it can be easily removed and replaced with a standard open-end or socket wrench without disturbing the existing piping.

Features

- Trap module can be easily removed and replaced in minutes without having to disconnect any piping
- Trap modules can be used with most manufacturers' 2-bolt universal connector
- All stainless steel construction with hardened seat

Sample Specification

The steam trap module shall be designed to attach to the industry standard two-bolt universal connector. Trap module shall be of a thermostatic design. The universal connector shall conform to the two-bolt industry standard with integral strainer and blowdown options.

Installation and Maintenance

Mounts to any two-bolt quick change universal connector. Trap module is attached to the connector using two bolts and two sealing gaskets. When a new trap module is needed, it can be easily removed and replaced with a standard open-end or socket wrench without unthreading the existing piping. In vertical piping installations with upward flow, use of a blowdown valve is not recommended. Discharge would be in upward and unsafe direction.

Options

Universal Connectors are available with an integral strainer and blowdown valve. Connector is purchased separately. See the Universal Connectors section for more information.

Helpful Selection Information

Connector selection to use with the UT450: UC450 (no strainer), UC450SR (strainer), UC450SBR (strainer and blowdown). Select this model for steam systems with maximum working pressure of 450 PSIG.

MATERIALS

Body	Stainless Steel, AISI 420
Thermal Element	Stainless Steel, AISI 302
Disc & Seat	Stainless Steel, AISI 420
Insulation Cover	Stainless Steel, AISI 304
Bolts	Steel, ASTM A193 GR B7
Gaskets (2)	Spiral Wound 304 Stainless Steel with Grafoil Filler

CAPACITIES — Condensate (lbs/hr)

Model	Orifice Size	Steam Inlet Pressure (PSIG)												
		5	10	20	50	100	125	150	200	250	300	350	400	450
UT450	3/16"	441	625	882	1391	1827	1969	2095	2305	2483	2636	2777	2903	3019

Note: 5/64" low capacity orifice is available upon request.

UT450

Universal Style Quick-Change Trap Module

Thermostatic Steam Trap Module (mounts to **UC450** Universal Connectors)



UT450
Thermostatic Steam Trap Module shown with **UC450SL** Connectors

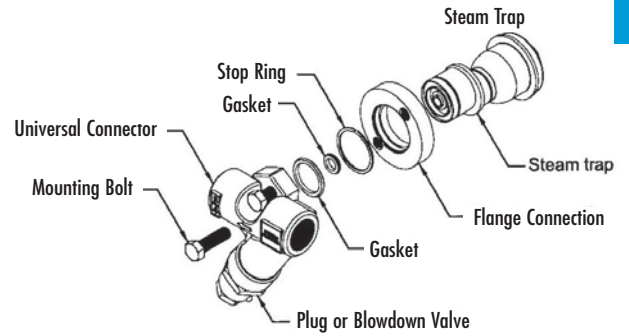

UT450 Trap Module may be mounted in any orientation

Horizontal Piping (Connector with Strainer)	Vertical Piping (Connector with Strainer)	Vertical or Horizontal Piping (No Strainer)
<p>Steam Flow to the Right or to the Left UC450SBR & UC450SB Connector shown below</p> <p>Trap shown with UC450SBR Connector</p> <p>Trap shown with UC450SB Connector</p>	<p>Steam Flow Downward UC450SBR & UC450SB Connector shown below</p> <p>Trap shown with UC450SBR Connector</p> <p>Trap shown with UC450SB Connector</p>	<p>Steam Flow Vertically or Horizontally UC450 Connector shown below</p> <p>Trap shown with UC450 Connector</p>

Connectors available in 1/2", 3/4" and 1" sizes in NPT and Socket-Weld Connections

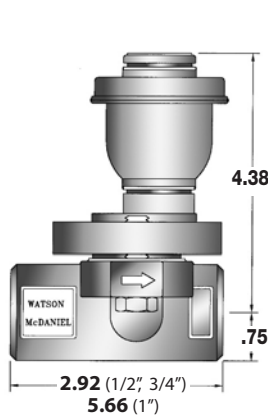

UT450 Trap Module with UC450 Connector

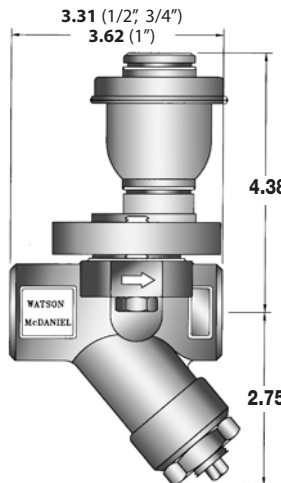

UT450 Trap Module with UC450S Connector (Strainer)

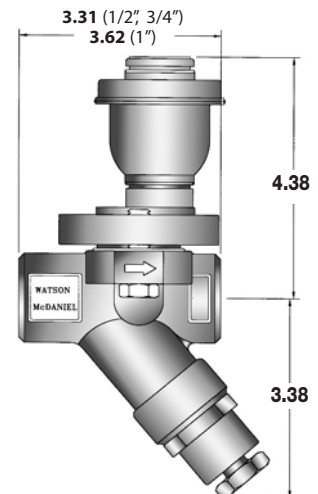

UT450 Trap Module with UC450SB Connector (Strainer & Blowdown)

UB450

Universal Style Quick-Change Trap Module

Bi-Metallic Steam Trap Module (mounts to UC450 Universal Connectors)

Model	UB450
Connections	Fits UC450 Series Universal Connectors
Body Material	Stainless Steel
PMO Max. Operating Pressure	450 PSIG
TMO Max. Operating Temperature	662°F
PMA Max. Allowable Pressure	720 PSIG @ 100°F
TMA Max. Allowable Temperature	800°F @ 400 PSIG

Steam trap modules **can be used with other manufacturers' Universal Connectors.**

Typical Applications

The **UB450** Series Bi-Metallic Steam Trap Modules are used in steam tracing applications (for process line heating, instrumentation and winterization, general steam jacketing). In tracing applications, the externally-adjustable (temperature adjustment) bi-metal element provides accurate control of condensate discharge temperature as required to maintain a specific product temperature as well provide maximum usage of energy.

How It Works

Bi-metallic plates of dissimilar metals which are connected to the valve seat assembly respond to temperature variations. At relatively cool conditions, the trap is open for the discharge of condensate. When the temperature of the condensate is equal to or higher than the set temperature, the metals react and expand, closing the trap. External field-adjustability of the bi-metal element allows control of the condensate discharge temperature. Trap module is fastened to the universal connector using 2 bolts.

Features

- Excellent for various steam tracing and small process applications where maximum energy usage is desired
- Field-adjustable bimetal element allows control of condensate discharge temperature, providing maximum use of additional energy in the condensate
- Internal screen and seat/plug design help prevent pipe scale and debris from accumulating on seating surfaces to provide trouble-free operation

Installation and Maintenance

Universal connector is first permanently threaded or welded into piping system. Trap module is attached to the universal connector using two bolts. If the trap fails for any reason, replace only the trap module. In vertical piping installations with upward flow, use of a blowdown valve is not recommended. Discharge would be in upward and unsafe direction.

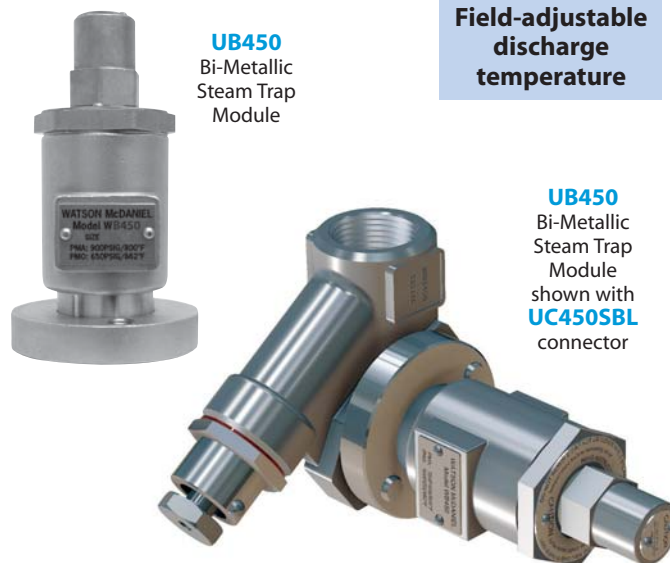

MATERIALS	
Body and Cover	Stainless Steel, A-351, Gr. CF8
Bimetal Element	GB14
Valve Seat	17-4 Ph Stainless Steel
Gaskets (2)	Spiral Wound 304 Stainless Steel with Grafoil Filler

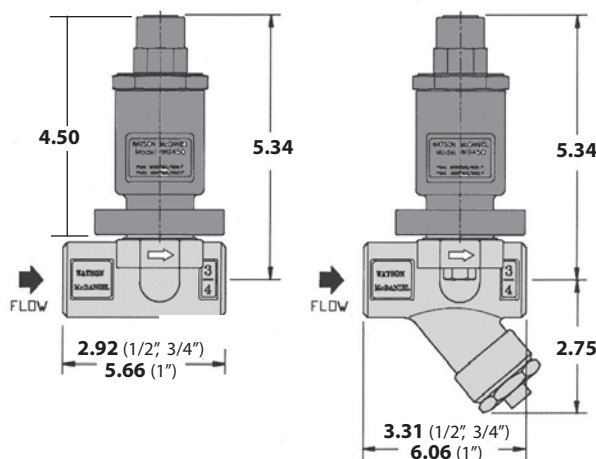

Shown with UC450 & UC450S Connectors

Set Temperature	Maximum Trap Capacities at Various Inlet Pressures and Set Temperatures – Condensate (lbs/hr)											
	Steam Inlet Pressure (PSIG)											
	15	30	50	100	125	150	200	250	300	350	400	450
220°F	56	70	102	144	161	177	204	228	250	270	289	306
240°F	116	164	212	300	336	368	425	475	520	562	600	637
260°F	134	190	245	346	387	424	490	548	600	648	693	735
280°F	143	202	261	370	413	453	523	584	640	691	739	784

- Notes:**
- 1) Capacities in chart are based on discharging condensate to atmosphere with a condensate temperature of 200° F.
 - 2) Contact factory for additional information including other condensate set and discharge temperatures.
 - 3) To ensure proper operation and eliminate possible steam loss, the Set Temperature should be lower than 27 °F subcool (degrees below inlet steam saturation temperature).

Introduction

What is Clean Steam or Pure Steam?

Clean Steam is steam that is made from deionized or distilled water in specialty boilers or steam generators. It is typically used in pharmaceutical applications such as sterilizers, fermenters and bioreactors as well as in the food production industries, distilleries and hospitals. Clean Steam should be used on any process that utilizes steam in such a way that it may come into direct contact with the end product and cause contamination. Industrial grade steam (most common grade of steam) is unsuitable for direct product contact because it contains contaminants from boiler additives, rust, and other heat transfer equipment. Pure Steam is clean steam that is produced to be virtually free of pyrogens and endotoxins, and is defined as "Water For Injection" or WFI.

Materials of construction

The Ultra-Pure water that is used to make clean steam has been depleted of all of its ions during the purification process, making it very chemically aggressive to metals, or "ion hungry." Therefore, only corrosion resistant metals such as 316 Stainless Steel can be used in products that handle clean steam. It's often required that the Stainless Steel in contact with Clean Steam must be passivated, a chemical process that removes any residual surface iron and promotes Chrome Oxide formation, further improving corrosion resistance.

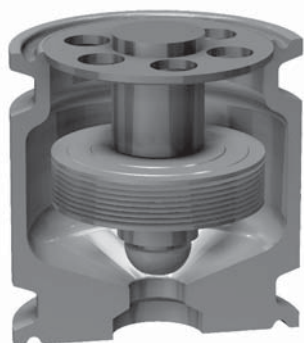

Surface Finish

Smoothing the surfaces by means of polishing reduces the ridges and crevices where micro-organisms (bacteria) may grow. While mechanical polishing will reduce the surface ridges significantly, electro-polishing is required to meet the standards of sanitary systems. Electro-polishing is an electro-chemical process that smoothes the surface of a metal object by removing surface metal ion by ion. Ra is measured in microinches and refers to the smoothness of a surface. The lower the Ra number, the smoother the surface and the less chance for surface contamination and microorganism growth.





FDA300



FDA400



FDA500



FDA600



FDA800

Clean Steam

62-65

Model	Body Material	PMO (PSIG)	Sizes	Connections	Page No.
FDA300	Stainless Steel	90	1 1/2"	Tri-Clamp	113
FDA400	Stainless Steel	90	1/2", 3/4"	Tri-Clamp	114
FDA500	Stainless Steel	90	1/2", 3/4", 1"	Tri-Clamp, NPT, TW	116
FDA600	Stainless Steel	110	1/2", 3/4", 1"	Tri-Clamp, NPT, TW	118
FDA800	Stainless Steel	150	1/2"	Tri-Clamp, NPT, TW	119

Sanitary Steam Traps Vs. Clean Steam Traps

Steam traps to be installed in sanitary piping systems must adhere to stringent design standards beyond traps merely suitable for clean steam applications.

Sanitary Steam Traps are designed to offer free flow through internal passages by incorporating very smooth internal finishes. The internal electro-polish finish on a sanitary steam trap must be between 20-25 Ra while the external finish is usually between 25-32 Ra. Because the system must be periodically passivated to provide sterilization, these traps offer a sanitary tri-clamp connection on the body to allow for removal of the thermal element. Removal of the element allows unobstructed flow through the trap during passivation. The FDA300, FDA400 & FDA500 are Sanitary Steam Traps.

Clean Steam Traps are steam traps designed for the same functionality as the sanitary traps, but do not offer the same level of surface finish, RA. Therefore clean steam traps cannot be used when a sanitary specified application is required.

Clean-in-place (CIP) & Sterilization-in-place (SIP)

CIP is a system which allows the automatic cleaning and disinfecting of plant equipment without dismantling, using cleaning fluids such as detergents, acids, alkalis, and water. CIP uses a high flow, highly turbulent solution to remove soil in the system. Chemicals are used to break up and remove the remaining soil. Sanitizer is then used to kill remaining microorganisms.

SIP is the process of sterilizing plant equipment without dismantling, usually following CIP procedures. SIP uses low pressure steam for sterilization purposes – typically 30 – 35 psig. The steam trap bodies must be passivated to remove any residual iron deposits as well as to promote a chrome oxide layer to enhance corrosion resistance of the stainless steel.

Connections

Because different facilities may identify different areas of potential contamination in a piping system, various end connections are available to satisfy customer needs.

Sanitary Tri-Clamp - A quick disconnect type fitting that meets sanitary piping standards allowing piping systems or products to be easily dismantled.

Tube Weld (TW) – a connection offered where welding of the steam trap is preferred for sanitary applications

NPT – a standard national pipe thread taper connection offered for applications with less stringent requirements, often considered on main line drip applications

Manufacturing and Design Standards

ASME BPE – Provides requirements of equipment used in bioprocessing, pharmaceutical and other applications that require high hygienic levels.

USP 24 – Standard for Pharmaceutical Grade Water which specifies the chemical composition of the allowable number of contaminants.

FDA CFR Title 21-177.1550 – Standard for perfluoro-carbon resins that may be safely used as components intended to contact food.

3A Sanitary Standards – Standards provide material specifications, design criteria and other necessary information for equipment types to satisfy public health concerns where a high degree of sanitation is required.

Clean Steam Thermostatic Steam Trap (Repairable)

Thermostatic Clean Steam

High-Capacity Sanitary

Model	FDA300
Sizes	1 1/2"
Connections	Tri-Clamp
Body Material	Stainless Steel
PMO Max. Operating Pressure	90 PSIG
TMO Max. Operating Temperature	Saturated Steam Temperature
PMA Max. Allowable Pressure	145 PSIG up to 338°F
TMA Max. Allowable Temperature	350°F @ 132 PSIG

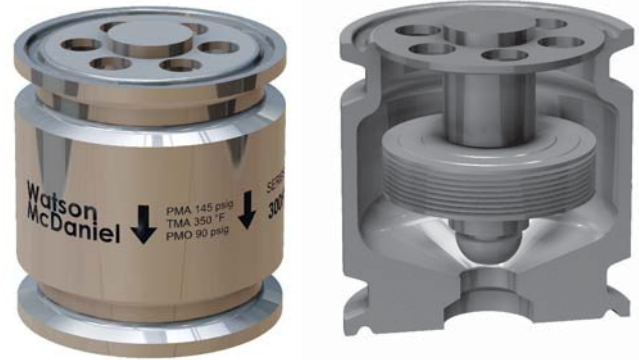

Typical Applications

PROCESS: FDA300 Series high-capacity thermostatic clean steam traps are used on clean steam applications, and for condensate drainage on CIP/SIP systems and various process vessels.

How It Works

This trap contains a welded 316L stainless steel thermal element that expands when heated and contracts when cooled. When air and subcooled condensate are present, the trap is in an open discharge position. When steam reaches the trap, the element expands, closing the trap tightly.

Features

- All wetted parts are 316L stainless steel
- Electro-polish finish of 20-25 microinches RA on internal surfaces of body
- Electro-polish finish of 25-32 microinches RA on external surfaces of body
- Operates close to saturation curve to minimize condensate back-up
- Completely self-draining in the vertical downward flow orientation

Sample Specification

The steam Trap shall be all 316L stainless steel thermostatic type with a balanced pressure bellows that operates close to saturated steam temperatures. Internal body parts shall have an electro-polish finish of 20-25 microinches RA internally and a 25-32 finish externally. The unit shall have a split-body sanitary clamp design for easy maintenance. Trap shall be completely self-draining when mounted vertically.

Installation and Maintenance

This trap is designed for installation in a vertical, downward flow orientation to ensure that the self-draining clean steam requirement is satisfied.

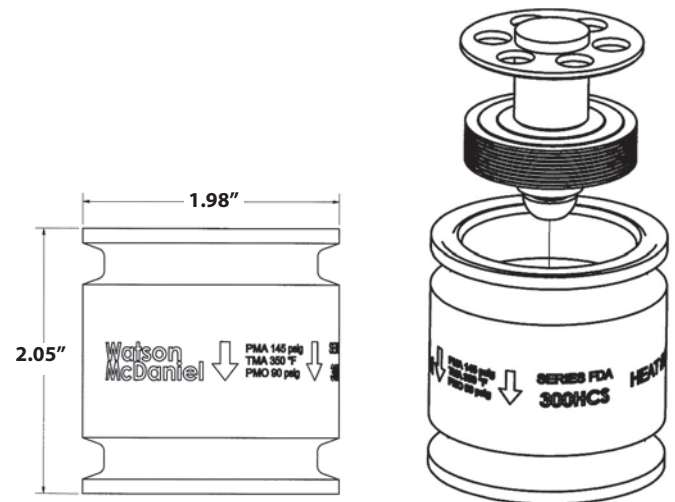

Size/Connection Inlet x Outlet	Model Code	Orifice Size	Weight lbs
1 1/2" TC x TC	FDA300-16-TCTC	0.394	2.25

MATERIALS

Body	Stainless Steel, AISI 316L
Element Plate	Stainless Steel, AISI 316L
Thermal Element	Stainless Steel, AISI 316L
Clamp	Stainless Steel, AISI 304

CAPACITIES – Condensate (lbs/hr)

Model	Orifice (Inches)	Differential Pressure (PSI)					
		5	10	20	50	75	90
FDA300	0.394	216	368	702	2214	4300	5904

Note: Capacities at 9°F below saturated steam temperature

Steam Traps

Clean Steam Thermostatic Steam Trap

(Repairable)

FDA400
Thermostatic Clean Steam

Model	FDA401, FDA402, FDA403
Sizes	1/2", 3/4"
Connections	Tri-clamp
Body Material	Stainless Steel
PMO Max. Operating Pressure	90 PSIG
TMO Max. Operating Temperature	Saturated Steam Temperature
PMA Max. Allowable Pressure	145 PSIG up to 338°F
TMA Max. Allowable Temperature	350°F @ 132 PSIG

Typical Applications

DRIP, PROCESS: FDA400 Series thermostatic clean steam traps are used in clean steam applications such as drainage for CIP/SIP systems and various process vessels. The universal horizontal connection allows the trap body to swivel to any angle. The FDA400 Series allows for a 90 degree connection on either the inlet or outlet capable of 360 degree orientation. Available with 2°F sub-cool bellows.

How It Works

This trap contains a welded 316L stainless steel thermal element that expands when heated and contracts when cooled. When air and sub-cooled condensate are present, the trap is in an open discharge position. When steam reaches the trap, the element expands, closing the trap tightly.

Features

- Universal horizontal connection swivels to any angle
- All wetted parts are 316L stainless steel
- Electro-polish finish of 20-25 microinches RA on internal surfaces of body
- Electro-polish finish of 25-32 microinches RA on external surfaces of body
- Operates close to saturation curve to minimize condensate back-up
- Completely self-draining in the vertical downward flow orientation

Sample Specification

The Steam Trap shall be all 316L stainless steel thermostatic type with a balanced pressure bellows that operates close to saturated steam temperatures. Inlet, outlet or both connections must contain a 90° swivel arrangement capable of 360° orientation. Internal body parts shall have an electro-polish finish of 20-25 microinches RA internally and a 25-32 finish externally. The unit shall have a split-body sanitary clamp design for easy maintenance. Trap shall be completely self-draining when mounted vertically.

Installation and Maintenance

Trap is designed for installation in a vertical, downward flow orientation to ensure that the self-draining clean steam requirement is satisfied.



Sanitary Clamp for Trap Body

Size/Connection Inlet x Outlet	Model Code	Port Configuration		Weight lbs
		Inlet	Outlet	
9/64" Orifice (0.141)				
1/2" TC x TC	FDA401-12-TCTC	90°	90°	3
1/2" TC x TC	FDA402-12-TCTC	90°	Straight	3
1/2" TC x TC	FDA403-12-TCTC	Straight	90°	3
5/16" Orifice (0.312)				
3/4" TC x TC	FDA411-13-TCTC	90°	90°	3
3/4" TC x TC	FDA412-13-TCTC	90°	Straight	3
3/4" TC x TC	FDA413-13-TCTC	Straight	90°	3

MATERIALS

Body	Stainless Steel, AISI 316L
Gasket	Teflon/Encapsulated Viton
Element Plate	Stainless Steel, AISI 316L
Thermal Element	Stainless Steel, AISI 316L
Clamp	Stainless Steel, AISI 304

CAPACITIES — Condensate (lbs/hr)

Model	Orifice (inches)	Differential Pressure (PSI)					
		5	10	20	50	75	90
FDA400	9/64	140	240	400	690	850	950
FDA410	5/16	850	1200	1695	2690	3165	3400

Note: Capacities at 10°F below saturation.

FDA400 Series Connections: 1/2" & 3/4"

Units: inches

FDA401 9/64" Orifice (0.141) Inlet: 90° Angle
FDA411 5/16" Orifice (0.312) Outlet: 90° Angle

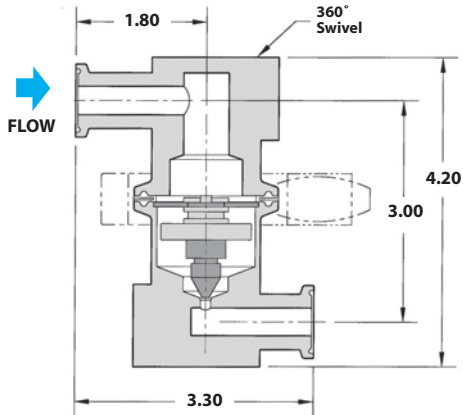

FDA402 9/64" Orifice (0.141) Inlet: 90° Angle
FDA412 5/16" Orifice (0.312) Outlet: Straight

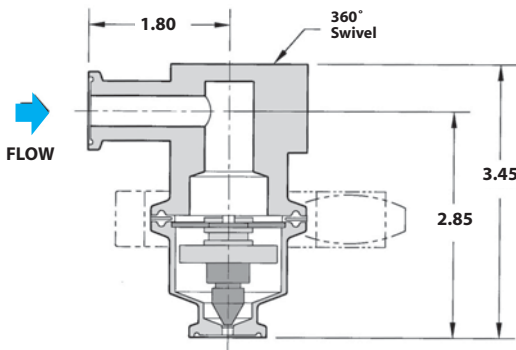

FDA403 9/64" Orifice (0.141) Inlet: Straight
FDA413 5/16" Orifice (0.312) Outlet: 90° Angle

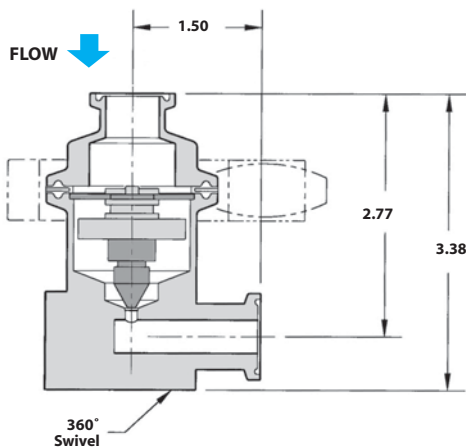

Steam Traps

Clean Steam Thermostatic Steam Trap

(Repairable)

FDA500

Thermostatic Clean Steam

Model	FDA500, FDA510
Sizes	1/2", 3/4", 1", 1 1/2"
Connections	Tri-clamp, NPT, Tube Weld
Body Material	Stainless Steel
PMO Max. Operating Pressure	90 PSIG
TMO Max. Operating Temperature	Saturated Steam Temperature
PMA Max. Allowable Pressure	145 PSIG up to 338°F
TMA Max. Allowable Temperature	350°F @ 132 PSIG

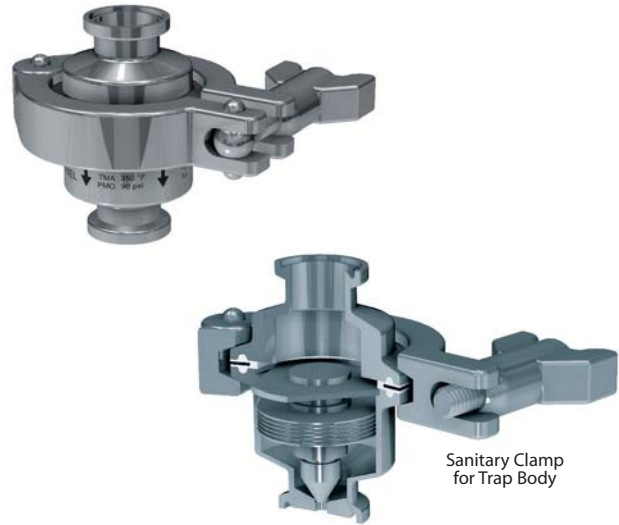

Typical Applications

DRIP, PROCESS: FDA500 Series thermostatic clean steam traps are used in clean steam applications as drip traps on piping runs as well as for drainage for CIP/SIP systems and various process vessels. Available with 2°F sub-cool bellows.

How It Works

This trap contains a welded 316L stainless steel thermal element that expands when heated and contracts when cooled. When air and sub-cooled condensate are present, the trap is in an open discharge position. When steam reaches the trap, the element expands, closing the trap tightly.

Features

- All wetted parts are 316L stainless steel
- Electro-polish finish of 20-25 microinches RA on **internal** surfaces of body. Consult factory for 15RA max surface finish option.
- Electro-polish finish of 25-32 microinches RA on **external** surfaces of body
- Operates close to saturation curve to minimize condensate back-up
- Completely self-draining in the vertical downward flow orientation

Sample Specification

The steam Trap shall be all 316L stainless steel thermostatic type with a balanced pressure bellows that operates close to saturated steam temperatures. Internal body parts shall have an electro-polish finish of 20-25 microinches RA internally and a 25-32 finish externally. The unit shall have a split-body sanitary clamp design for easy maintenance. Trap shall be completely self-draining when mounted vertically.

Installation and Maintenance

This trap is designed for installation in a vertical, downward flow orientation to ensure that the self-draining clean steam requirement is satisfied. If purchased with tube weld connections with the intention of welding in-line, the thermal element and gasket must be removed during the welding process or heat damage may occur.

Size/Connection Inlet x Outlet	Model Code	Orifice Size	Weight lbs
1/2" TC x TC	FDA500-12-TCTC	9/64"	2.00
3/4" TC x TC	FDA500-13-TCTC	9/64"	2.00
1" TC x TC	FDA500-14-TCTC	9/64"	2.25
1 1/2" TC x TC	FDA500-16-TCTC	9/64"	2.25
1/2" TC x TC	FDA510-12-TCTC	5/16"	2.00
3/4" TC x TC	FDA510-13-TCTC	5/16"	2.00
1" TC x TC	FDA510-14-TCTC	5/16"	2.25
1 1/2" TC x TC	FDA510-16-TCTC	5/16"	2.25
1/2" TC x NPT	FDA500-12-TCNP	9/64"	2.00
3/4" TC x NPT	FDA500-13-TCNP	9/64"	2.00
1" TC x NPT	FDA500-14-TCNP	9/64"	3.00
1 1/2" TC x NPT	FDA500-16-TCNP	9/64"	2.25
1/2" TC x NPT	FDA510-12-TCNP	5/16"	2.25
3/4" TC x NPT	FDA510-13-TCNP	5/16"	2.25
1" TC x NPT	FDA510-14-TCNP	5/16"	2.25
1 1/2" TC x NPT	FDA510-16-TCNP	5/16"	2.25
1/2" TW x TW	FDA500-12-TWTW	9/64"	2.25
1/2" TW x TW	FDA510-12-TWTW	5/16"	2.25

MATERIALS

Body	Stainless Steel, AISI 316L
Gasket	Teflon/Encapsulated Viton
Element Plate	Stainless Steel, AISI 316L
Thermal Element	Stainless Steel, AISI 316L
Clamp	Stainless Steel, AISI 304

CAPACITIES – Condensate (lbs/hr)

Model	Orifice (Inches)	Differential Pressure (PSI)					
		5	10	20	50	75	90
FDA500	9/64	140	240	400	690	850	950
FDA510	5/16	850	1200	1695	2690	3165	3400

Note: Capacities at 10°F below saturation.



Typical Clean Steam Application

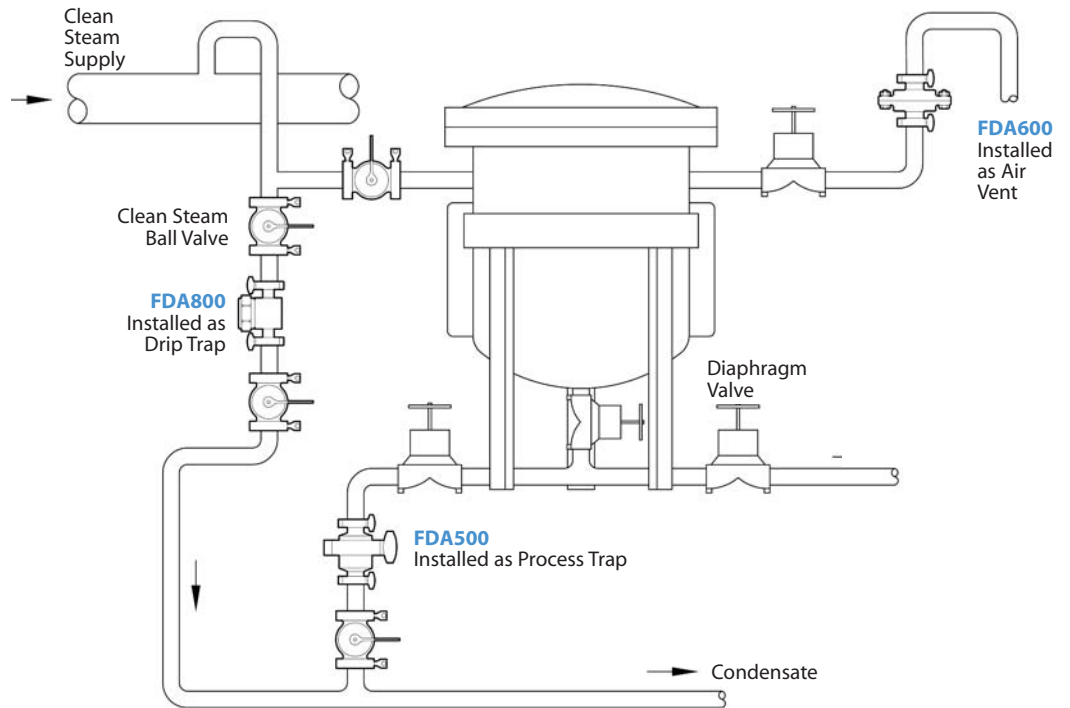

FDA500 Series Connections: 1/2", 3/4" & 1"

Units: inches

Tri-Clamp Connection: TC x TC

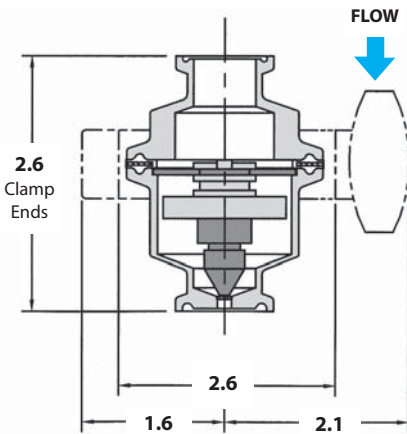

Connection: NP x NP or TC x NP

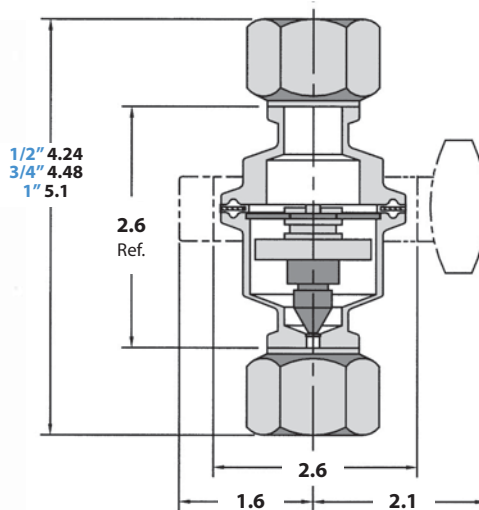

Tube-weld Connection: TW x TW

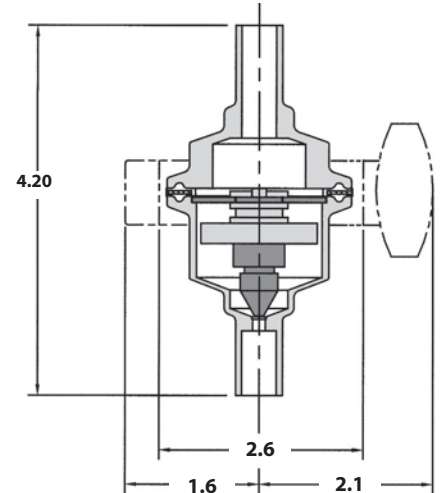

Steam Traps

Clean Steam Thermostatic Steam Trap

FDA600
Thermostatic Clean Steam

(Repairable)

Model	FDA600
Sizes	1/2", 3/4", 1"
Connections	Tri-clamp, NPT, Tube Weld
Body Material	Stainless Steel
PMO Max. Operating Pressure	110 PSIG
TMO Max. Operating Temperature	Saturated Steam Temperature
PMA Max. Allowable Pressure	145 PSIG up to 338°F
TMA Max. Allowable Temperature	350°F @ 132 PSIG

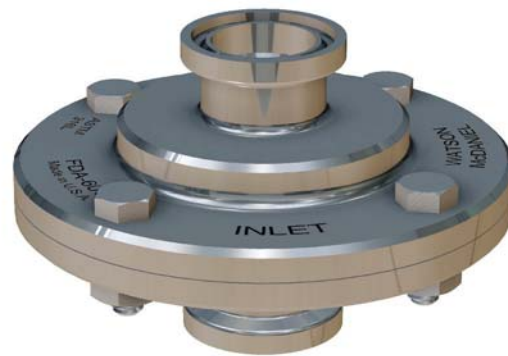

Typical Applications

DRIP, PROCESS: FDA600 Series thermostatic clean steam traps are used as drip traps on piping runs on clean steam applications and for drainage for CIP/SIP systems and various process vessels.

How It Works

This trap contains a welded 316L stainless steel thermal element that expands when heated and contracts when cooled. When air and subcooled condensate are present, the trap is in an open discharge position. When steam reaches the trap, the element expands, closing the trap tightly.

Features

- All wetted parts are 316L stainless steel
- Operates close to saturation curve to minimize condensate back-up
- Completely self-draining in the vertical downward flow orientation

Sample Specification

The Steam Trap shall be all 316L stainless steel thermostatic type with a balanced pressure bellows that operates close to saturated steam temperatures. The unit shall have a split-body design for easy maintenance. Trap shall be completely self-draining when mounted vertically.

Installation and Maintenance

Trap is designed to be installed in a vertical, downward flow orientation to ensure that the self-draining clean steam requirement is satisfied. If purchased with tube weld connections with the intention of welding in-line, the thermal element and gasket must be removed during the welding process or heat damage may occur.

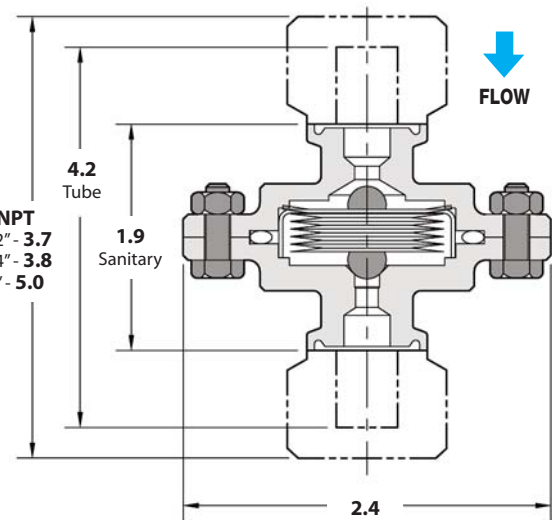

Units: Inches

Size/Connection Inlet x Outlet	Model Code	PMO PSI	Weight lbs
1/2" TC x TC	FDA600-12-TCTC	110	1.25
3/4" TC x TC	FDA600-13-TCTC	110	1.25
1" TC x TC	FDA600-14-TCTC	110	1.25
1/2" TC x NPT	FDA600-12-TCNP	110	1.25
3/4" TC x NPT	FDA600-13-TCNP	110	1.25
1" TC x NPT	FDA600-14-TCNP	110	1.25
1/2" NPT x NPT	FDA600-12-NPNP	110	1.25
3/4" NPT x NPT	FDA600-13-NPNP	110	1.25
1" NPT x NPT	FDA600-14-NPNP	110	1.25
1/2" TW X TW	FDA600-12-TWTW	110	1.25

CAPACITIES — Condensate (lbs/hr)

Condensate Temp Below Saturation	Differential Pressure (PSI)						
	1	5	10	20	50	75	110
10 °F	32	105	175	290	615	805	1160
20 °F	42	115	225	440	1060	1500	1850
Cold Water	735	1070	1375	1900	3100	3500	4600

MATERIALS

Body	Stainless Steel, AISI 316L
Thermal Element	Stainless Steel, AISI 316L
O-Ring, FDA Grade	Teflon Coated Silicone/FEP
Nuts & Bolts	Stainless Steel, AISI 316L

Model	FDA800
Sizes	1/2"
Connections	Tri-Clamp, NPT, Tube Weld
Body Material	Stainless Steel
PMO Max. Operating Pressure	150 PSIG
TMO Max. Operating Temperature	500°F
PMA Max. Allowable Pressure	230 PSIG @ 850°F
TMA Max. Allowable Temperature	850°F @ 230 PSIG



NPT

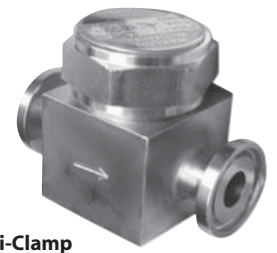

Tri-Clamp

Typical Applications

DRIP: The **FDA800 Series** thermodynamic clean steam traps are used as drip traps on steam mains in CIP/SIP systems and drainage for separators and filters.

How It Works

Using the thermodynamic properties of flash steam, this trap features a disc that is pushed open by incoming condensate, then closes tightly when steam enters the trap. Because it normally operates in an open position, condensate is continuously discharged from the line. Steam entering the trap creates an internal pressure that forces the valve to close tightly, preventing the steam from escaping.

Features

- Small and compact
- All 316L stainless steel components
- Works in any position (horizontal preferred)

Sample Specification

The steam trap shall be a thermodynamic disc type with an all 316L stainless steel construction and integral seat design. Unit shall be capable of installation in any orientation and self-draining when mounted vertically.

Installation and Maintenance

Can be installed in any position; however, horizontal is preferred. For self-draining requirements, the trap should be installed vertically. Installation should include a strainer before the trap inlet since dirt is a common cause of premature failure.

MATERIALS

Body	Stainless Steel, AISI 316L
Disc	Stainless Steel, AISI 316L
Cap	Stainless Steel, AISI 316L

Size/Connection Inlet x Outlet	Model Code	PMO PSI	Weight lbs
1/2" TC x TC	FDA800-12-TCTC	150	1.5
1/2" TW x TW	FDA800-12-TWTW	150	1.5
1/2" NPT x NPT	FDA800-12-NPNP	150	1.5

Units: Inches

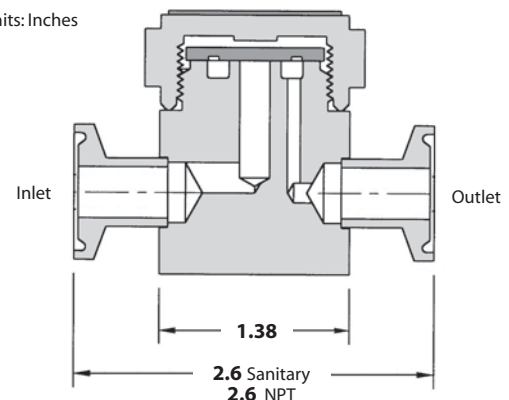

CAPACITIES — Condensate (lbs/hr)

Size	Differential Pressure (PSI)											
	3.5	5	10	15	20	25	30	40	50	75	100	150
1/2"	180	185	190	195	200	215	220	230	250	310	375	500

Note: Maximum back pressure not to exceed 80% of inlet pressure.

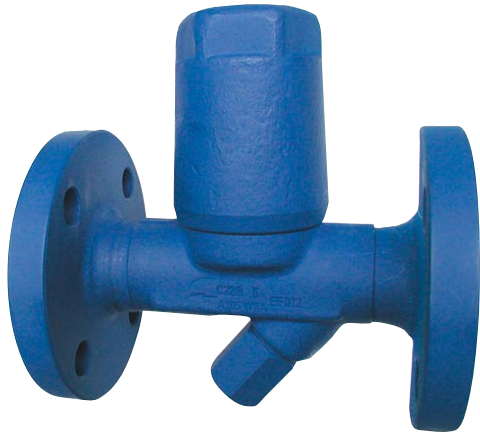

Bi-Metallic Steam Traps

The **WPN Series Bi-Metallic Steam Traps** are used in steam tracing, steam main drips and non-critical process equipment. They can be used on outdoor applications that are subject to freezing. The WPN Series Traps are available in multiple sizes and pressures up to 2260 PSI.

Model	Body Material	PMO (PSIG)	Sizes	Connections	Pressure Controller	Max Diff. Pressure (PSI)
WPN-40	A105 Carbon Steel	470	1/2" - 2"	NPT, 150# or 300# FLG, SW, BW	R22	320
					R32	460
WPN-63	A182-F12CL2 Alloy Steel	823	1/2", 3/4", 1"	NPT, 300# FLG, SW, BW	R56	810
WPN-100	A182-F12CL2 Alloy Steel	1220	1/2", 3/4", 1"	NPT, 600# FLG, SW, BW	R90	1200
WPN-160	A182-F12CL2 Alloy Steel	1620	1/2", 3/4", 1"	NPT, 900# FLG, SW, BW	R130	1600
WPN-250	A182-F22CL3 Alloy Steel	2260	1/2", 3/4", 1"	NPT, 1500# FLG, SW, BW	R150	2230

Typical Applications

DRIP, TRACING: WPN Series Bi-metallic steam traps are used in steam tracing, steam main drips and non-critical process equipment. They are extremely robust and reliable, making them a suitable choice for high

pressure applications as well as outdoor applications that are subject to freezing. They are used in systems where a quick discharge of air, non-condensable gases and large quantities of cold water need to be discharged at start-up.

How It Works

When the system is cold, the trap is fully open; discharging air and cold condensate. When the bi-metallic plates inside the trap heat up, they expand; pulling the seat closed and restricting flow. Prior to steam temperature being reached, the trap shuts off tightly. Cooler temperatures cause the seat to open further. Therefore, trap capacity will increase when colder condensate is in contact with the Bi-metal element. Trap capacity is therefore given at different temperatures below saturated steam temperature.

Features

- Excellent for high-pressure and superheated steam applications
- Freeze-proof and resistant to waterhammer
- Suitable for superheated steam
- In-line repairable
- Trap can be welded into line

Sample Specification

Steam trap shall be Watson McDaniel WPN Series Bi-Metallic Steam Trap. Trap must be capable of being completely serviced while still in-line.

Installation and Maintenance

The trap can be installed in any orientation except with the cap facing downward. All internal components can be replaced while trap body remains in-line.

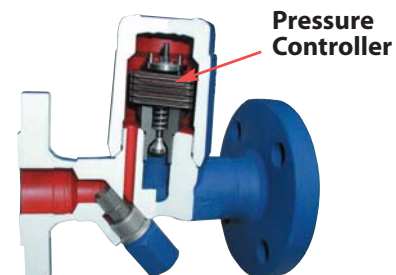

Max Differential Pressure for Pressure Controller	
Pressure Controller	Max Diff. Pressure PSI
R22	320
R32	460
R56	810
R90	1200
R130	1600
R150	2230

How to select a A WPN Trap:

- 1) Select a Pressure Controller that has a max differential pressure within the range of your application.
- 2) Select a Trap Body depending on System Pressure; WPN40 thru WPN250.
- 3) Select Connection Type & Size
- 4) Configure Model Code (see Examples to right)

Example Model Codes:

WPN40-A-R22-14-F150-ES

(Model WPN40, 320 PSI Max Differential Pressure, 1" 150# Flanged with External Strainer)

WPN63-C-R56-14-F600

(Model WPN63, 810 PSI Max Differential Pressure, 1" 600# Flanged with Standard Internal Strainer)

Model Configuration Chart

Position 1	Position 2	Position 3	Position 4		Position 5	Position 6			
Model	Body Material (Code)	Pressure Controller Code	Connection Size	Code	Connection Type Code	Strainer Selection Code			
WPN-40	Carbon Steel A105 (A)	R22 or R32	1/2"	12	F150, F300, N, SW	Internal Strainer (IS)			
			3/4"	13					
			1"	14					
			1 1/2"	16					
						2"	17	F150, F300, N, SW, BW	External Strainer (ES)
						1/2"	12		
						3/4"	13		
						1"	14		
WPN-63	Alloy Steel A182-F12CL2 (C)	R56	1/2"	12	F300, SW, BW				
			3/4"	13					
			1"	14					
WPN-100	Alloy Steel A182-F12CL2 (C)	R90	1/2"	12	F600, SW, BW				
			3/4"	13					
			1"	14					
WPN-160	Alloy Steel A182-F12CL2 (C)	R130	1/2"	12	F900, SW, BW				
			3/4"	13					
			1"	14					
WPN-250	Alloy Steel A182-F22CL3 (C)	R150	1/2"	12	F1500, SW, BW				
			3/4"	13					
			1"	14					

Model	WPN-40	
Sizes	1/2", 3/4", 1", 1 1/2", 2"	
Connections	NPT, 150# FLG, 300# FLG, SW, BW	
Body & Cover Material	A105 (C22.8)	
PMA ANSI Class 150 with 150# FLG	190 PSIG up to 437°F	
PMA ANSI Class 300 with 300# FLG	460 PSIG up to 772°F	
TMO Max. Operating Temperature (°F)	Approx. 100°F Superheat	
Pressure Controller	R22	R32
PMO Max. Operating Differential Pressure of Pressure Controller (PSI)	320	460

Note: SW = Socket Weld
 BW = Butt-Weld

- 1) = 18°F SUB-COOL
- 2) = 54°F SUB-COOL
- 3) = 68°F

The capacity charts show the maximum flow at factory setting.

Curve 1 Flow of Condensate at approx. 18°F below boiling temperature.

Curve 2 Flow of Sub-Cooled Condensate at approx. 54°F below boiling temperature.

Curve 3 Flow of Cold Condensate at about 68°F (during start-up of a cold system).

Cooler temperatures cause the seat in the controller to open wider; therefore, trap capacity will increase when colder condensate is in contact with the Bi-metal element. Trap capacity is given at different temperatures below saturated steam temperature

WPN-40 with R22 & R32 Controller
 1/2", 3/4", 1"

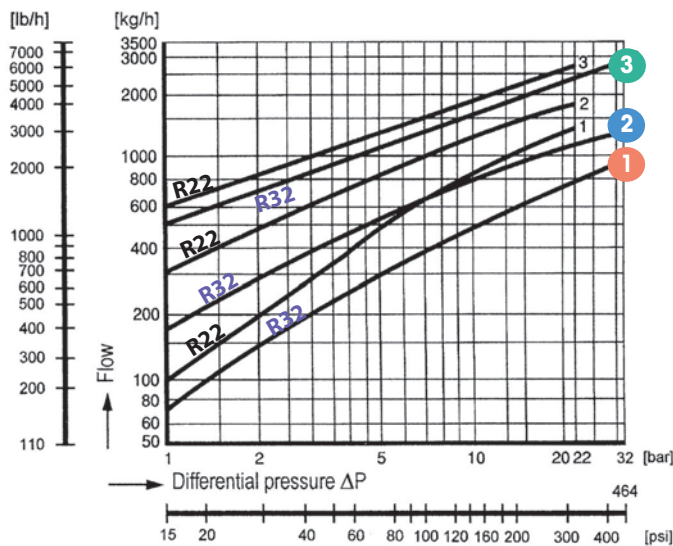

WPN-40 with R22 & R32 Controller
 1 1/2", 2"

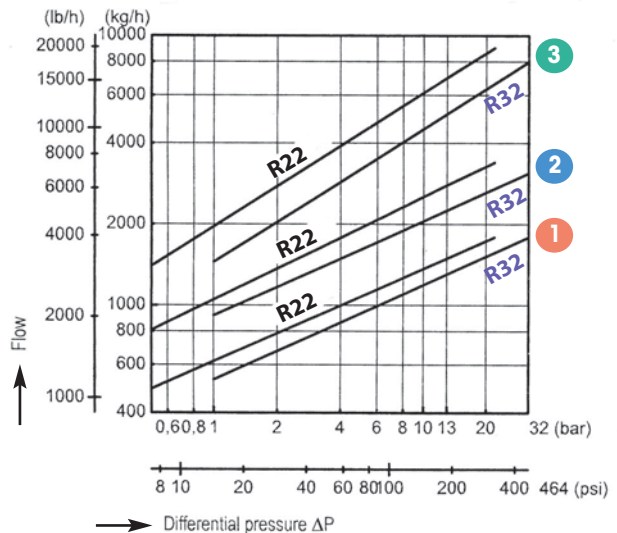

WPN-40 with R22 or R32 Controller (screw-on cover)

1/2", 3/4", 1"

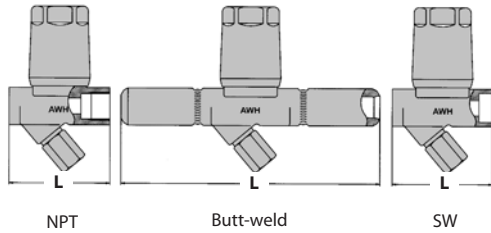
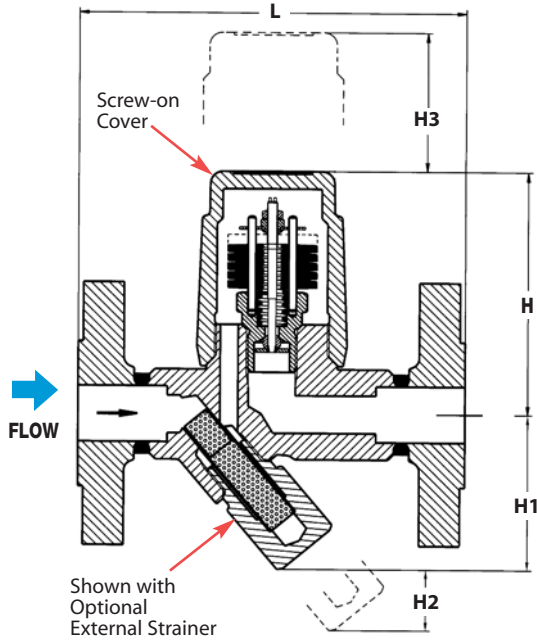

WPN-40 with R22 or R32 Controller (bolt-on cover)

1 1/2", 2"

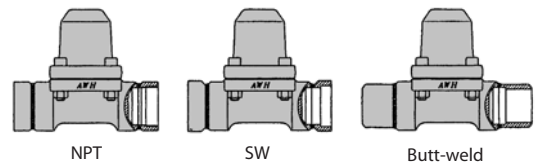
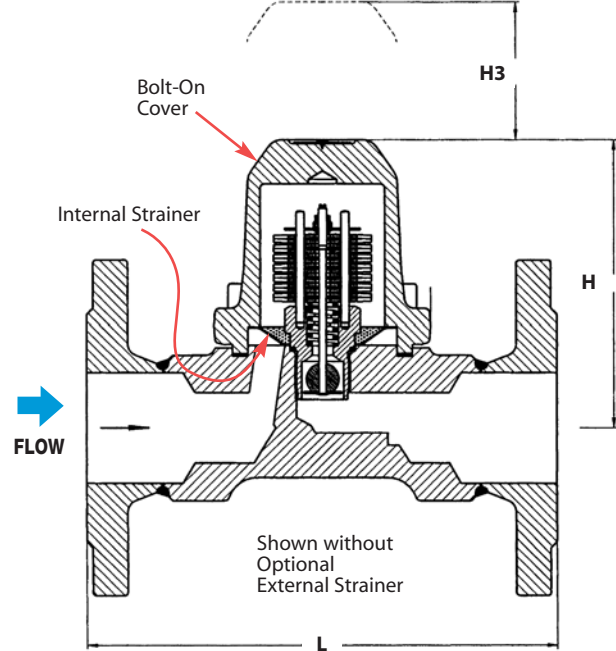

DIMENSIONS & WEIGHTS – inches

Model	Size	Connection	L	H	H1	H2	H3	Weight (lbs)
WPN-40	1/2", 3/4"	150#/300# FLG	5.90	3.92	2.44	1.20	2.8	7.7
	1"	150#/300# FLG	6.30	3.92	2.44	1.20	2.8	9.2
	1 1/2", 2"	150#/300# FLG	9.05	5.76	2.67	1.97	3.6	25.0
	1/2", 3/4"	NPT, SW	3.74	3.92	2.44	1.20	2.8	3.7
	1"	NPT, SW	3.74	4.12	2.16	1.20	2.8	4.6
	1 1/2"	NPT	6.30	5.76	2.67	1.97	3.6	17.6
	1 1/2"	SW	5.12	5.76	2.67	1.97	3.6	17.6
	2"	NPT, SW	8.27	5.76	2.67	1.97	3.6	17.6
	1/2", 3/4", 1"	Butt-weld	9.84	3.92	2.44	1.20	2.8	5.0
	1 1/2", 2"	Butt-weld	9.84	5.76	2.67	1.97	3.6	21.0

Model	WPN-63*	WPN-100	WPN-160	WPN-250
Sizes	1/2", 3/4", 1"	1/2", 3/4", 1"	1/2", 3/4", 1"	1/2", 3/4", 1"
Connections	300# FLG, SW, Butt-weld	600# FLG, SW, Butt-weld	900# FLG, SW, Butt-weld	1500# FLG, SW, Butt-weld
Body & Cover Material	Alloy Steel (A182-F12CL2)	Alloy Steel (A182-F12CL2)	Alloy Steel (A182-F12CL2)	Alloy Steel (A182-F22CL3)
Body Rating	ANSI 400	ANSI 600	ANSI 900	ANSI 1500
PMA Max. Allowable Pressure	810 PSIG up to 592°F	1200 PSIG up to 610°F	1600 PSIG up to 750°F	2180 PSIG up to 905°F
TMA Max. Allowable Temperature	1000°F @ 261 PSIG	1000°F @ 441 PSIG	1000°F @ 595 PSIG	1000°F @ 1305 PSIG
TMO Max. Operating Temperature	572°F	842°F	932°F	932°F
Pressure Controller	R56	R90	R130	R150
PMO Max. Operating Diff. Pressure of Pressure Controller	810 PSI	1200 PSI	1600 PSI	2230 PSI

WPN-63 / WPN-100 / WPN-160 / WPN-250

1/2", 3/4", 1"

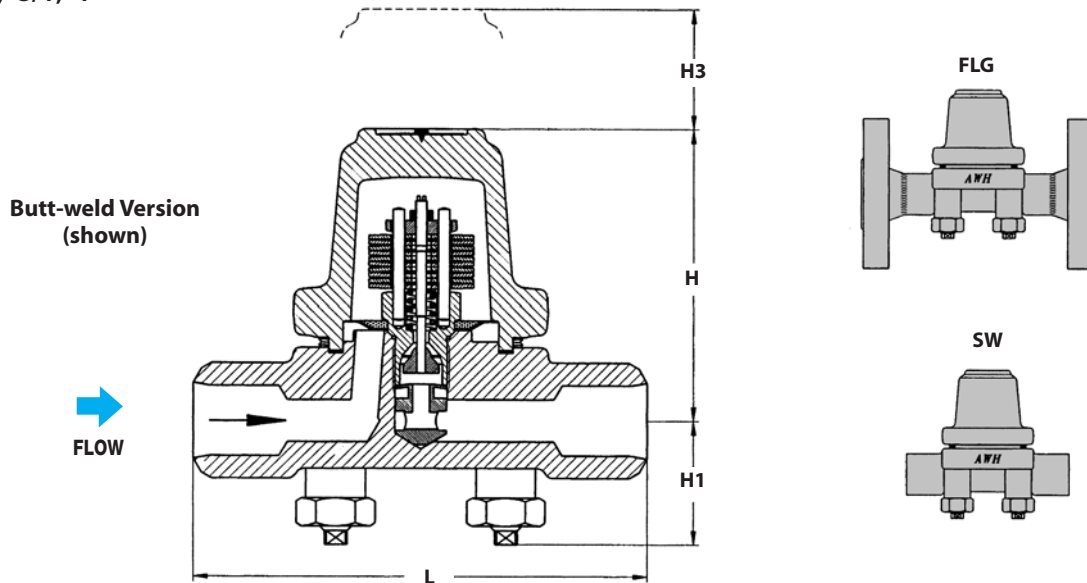

DIMENSIONS & WEIGHTS – inches							
Model	Size	Connection	L	H	H1	H3	Weight (lbs)
WPN-63, WPN-100, WPN-160, WPN-250	1/2", 3/4"	FLG*	8.26	4.16	1.68	2.8	17.6
	1"	FLG*	9.05	4.16	1.68	2.8	17.6
	1/2", 3/4", 1"	SW	6.30	4.16	1.68	2.8	10.0
		Butt-weld	6.30	4.16	1.68	2.8	10.0

* WPN-63: 300# FLG
WPN-100: 600# FLG
WPN-160: 900# FLG
WPN-250: 1500# FLG

The capacity charts show the maximum flow at factory setting.

- Curve 1 Maximum Flow quantity of Condensate at approximately 18 & 27°F below boiling temperature.
- Curve 2 Maximum Flow of Sub-Cooled condensate at approx. 54°F below boiling temperature (through back up of condensate).
- Curve 3 Maximum Flow quantity of Cold Condensate at about 68°F (during start-up of a cold system).

Cooler temperatures cause the seat in the controller to open wider; therefore, trap capacity will increase when colder condensate is in contact with the Bi-metal element. Trap capacity is given at different temperatures below saturated steam temperature.

WPN-63 • 1/2", 3/4", 1"

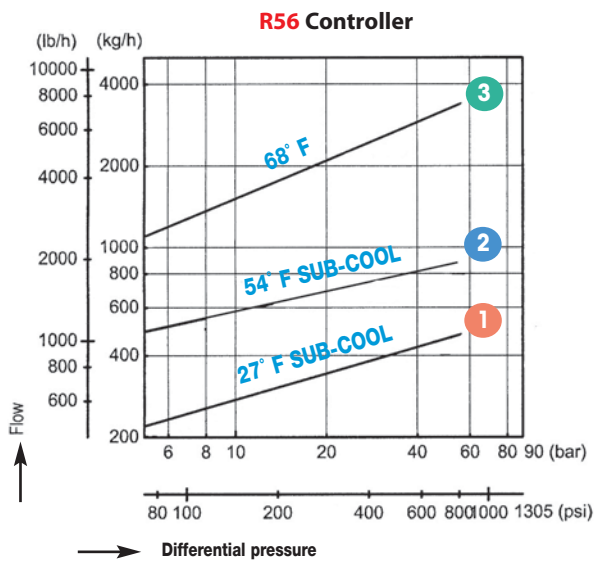

WPN-100 • 1/2", 3/4", 1"

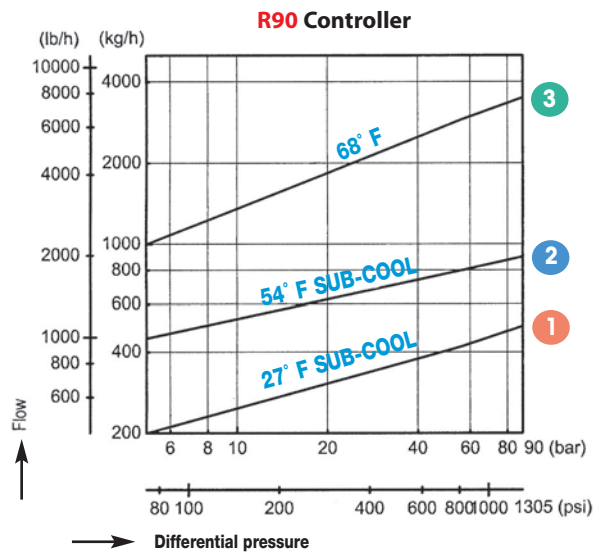

WPN-160 • 1/2", 3/4", 1"

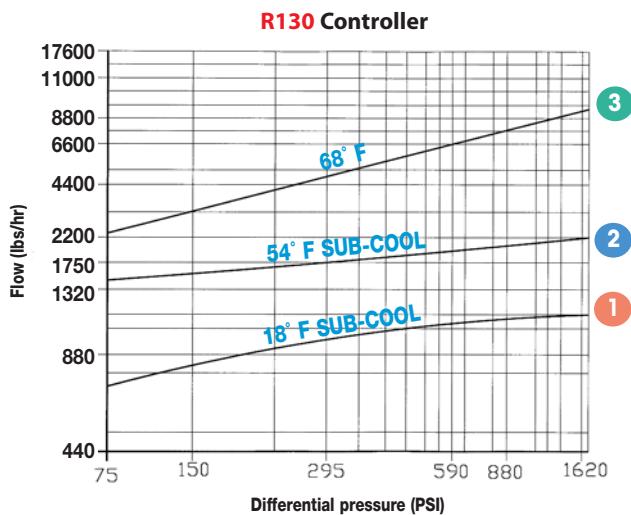

WPN-250 • 1/2", 3/4", 1"

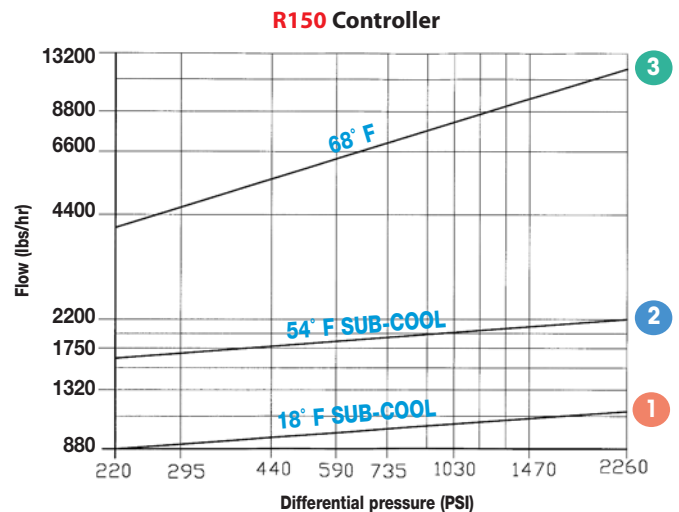

Steam Traps Steel Manifolds

FM/FSM Series Manifolds

Fabricated Carbon Steel • Forged Steel

Model	FM	FSM
Sizes	1/2", 3/4"	1/2", 3/4"
Connections	NPT, SW	NPT, SW
Body Material	Fabricated Carbon Steel	Forged Steel
PMO Max. Operating Pressure	720 PSIG	600 PSIG
Pressure/Temperature Rating	720 PSIG @ 508°F	600 PSIG @ 500°F

Typical Applications

FM / FSM manifolds are used for steam distribution TO the tracing system and for condensate collection FROM the tracing system. Commonly used in chemical and petrochemical facilities as well as in other industrial plants that have multiple tracing applications. Manifolding the steam distribution and condensate collection system not only cuts down on installation and maintenance costs, but also provides freeze protection. FSM Series manifolds have integral isolation valves.

Description FM

The FM manifold is fabricated from carbon steel and available with either NPT or Socket-weld connections. Condensate collection type are provided with a built-in siphon tube to minimize bi-phase flow, which reduces water hammer and allows flash steam space to prevent freeze damage.

Description FSM

The FSM manifold is manufactured from forged steel and is equipped with integral piston style valves. The unique sealing system of the valves utilize an austenitic stainless steel piston that slides into two rings composed of reinforced graphite ring stainless steel plates.

Features

- Compact design saves valuable plant space
- Available in 4, 6, 8 & 12 branch designs
- Available with pre-assembled steam trap stations
- Standard designs or custom built manifolds available
- Provides freeze protection
- Reduces installation and maintenance time
- On FSM Model valve bonnets are long neck type to allow for installation of insulation, keeping surface temperatures low for protection of personnel

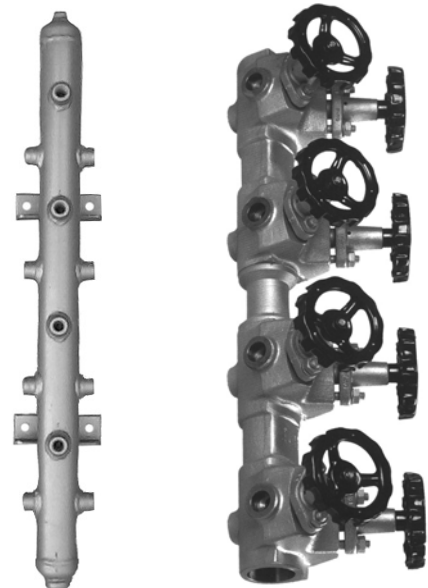

FM Manifold
(Carbon Steel)

FSM Manifold
(Forged Steel)

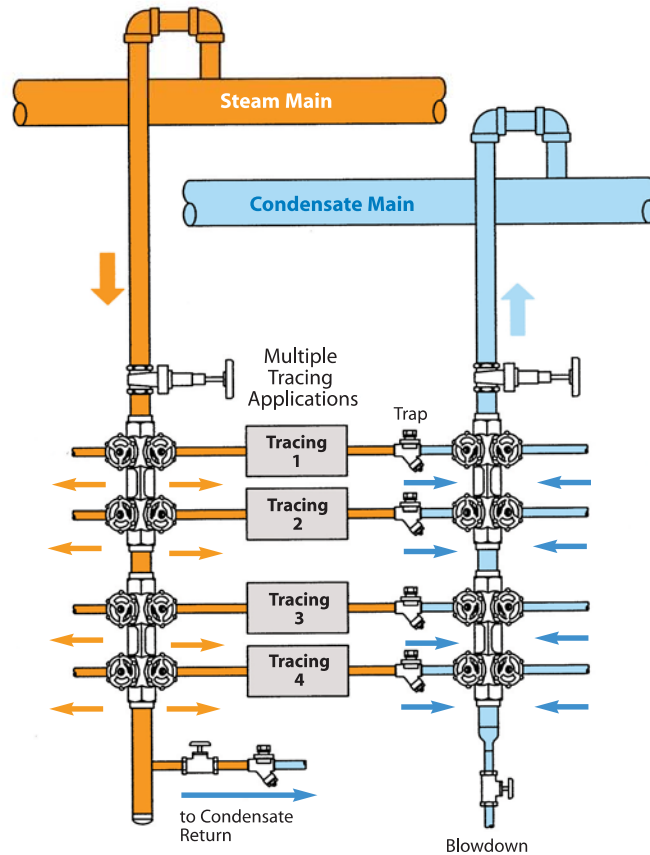

FSM Steam Distribution Manifold
Distributes Steam TO Tracing Applications

FSM Condensate Collection Manifold
Collects Condensate FROM Tracing Applications

Steam Traps Steel Manifolds

FM Series Manifolds

Fabricated Carbon Steel

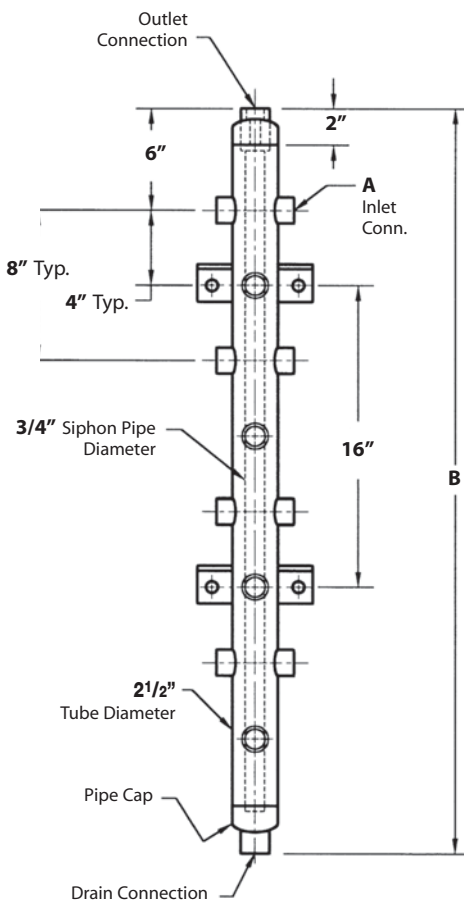
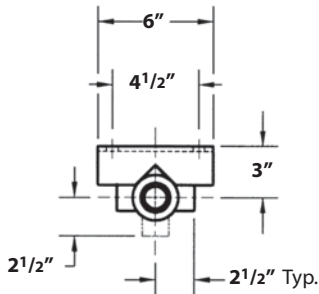

Description Vertical Mount	Model Code	Inlet (A)		# Front Conn.	# Side Conn.	Conn. Total	B Length (in)	Wt.. (lbs)
		Size	Type					
Condensate Collection (C) Manifolds								
4 side conn.	FM4-12-N-C	1/2"	NPT	4	0	4	24	25
4 side conn.	FM4-13-N-C	3/4"	NPT	4	0	4	24	27
4 side/2 front conn.	FM6-12-N-C	1/2"	NPT	4	2	6	24	27
4 side/2 front conn.	FM6-13-N-C	3/4"	NPT	4	2	6	24	29
8 side conn.	FM8-12-N-C	1/2"	NPT	8	0	8	40	40
8 side conn.	FM8-13-N-C	3/4"	NPT	8	0	8	40	42
8 side/4 front conn.	FM12-12-N-C	1/2"	NPT	8	4	12	40	46
8 side/4 front conn.	FM12-13-N-C	3/4"	NPT	8	4	12	40	48
12 side conn.	FM12A-12-N-C	1/2"	NPT	12	0	12	56	56
12 side conn.	FM12A-13-N-C	3/4"	NPT	12	0	12	56	58
Steam Distribution (D) Manifolds								
4 side conn.	FM4-12-N-D	1/2"	NPT	4	0	4	24	25
4 side conn.	FM4-13-N-D	3/4"	NPT	4	0	4	24	27
4 side/2 front conn.	FM6-12-N-D	1/2"	NPT	4	2	6	24	27
4 side/2 front conn.	FM6-13-N-D	3/4"	NPT	4	2	6	24	29
8 side conn.	FM8-12-N-D	1/2"	NPT	8	0	8	40	40
8 side conn.	FM8-13-N-D	3/4"	NPT	8	0	8	40	42
8 side/4 front conn.	FM12-12-N-D	1/2"	NPT	8	4	12	40	46
8 side/4 front conn.	FM12-13-N-D	3/4"	NPT	8	4	12	40	48
12 side conn.	FM12A-12-N-D	1/2"	NPT	12	0	12	56	56
12 side conn.	FM12A-13-N-D	3/4"	NPT	12	0	12	56	58

Connection Codes: **N** = NPT, **SW** = Socket Weld

For Socket Weld Connections: change **N** in Model code to **SW**. Example: **FM4-12-SW-C**

MATERIALS – FM

Body	Fabricated Carbon Steel
------	-------------------------

Steam Traps Steel Manifolds

FSM Series Manifolds

Forged Steel

DIMENSIONS & WEIGHTS – inches

Model	L	H	D	C	O	I	S	S1	S2	A	A1	B	B1	No. of Valves	No. of Holes	Weight (lbs)
FSM-4	4.33"	1.61"	3.94"	8.97"	10.63"	6.30"	13.03"	-	-	2.79"	1.22"	3.23"	2.79"	4	2 (M12)	23
FSM-8	4.33"	1.61"	3.94"	8.97"	10.63"	6.30"	-	28.1"	-	2.79"	1.22"	3.23"	2.79"	8	4 (M12)	49
FSM-12	4.33"	1.61"	3.94"	8.97"	10.63"	6.30"	-	-	36.22"	2.79"	1.22"	3.23"	2.79"	12	6 (M12)	72

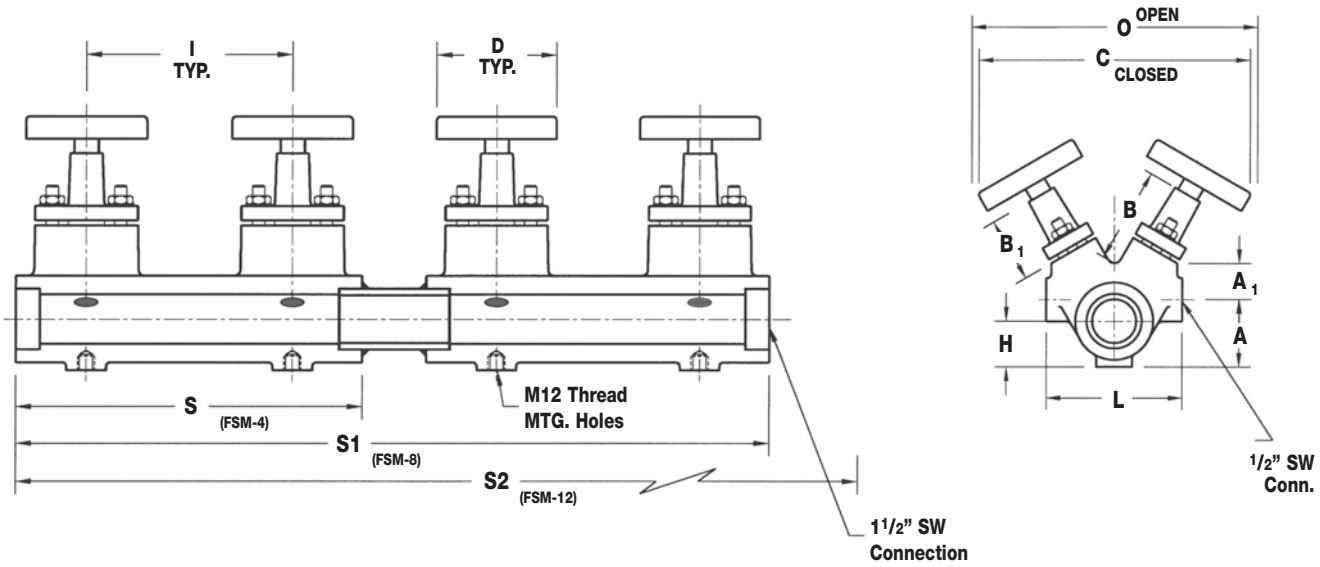

Description	Model Code	Connection		# of Branches
		Size	Type	
Condensate Collection (C) Manifolds				
4 Branches/4 Valves	FSM4-12-N-C	1/2"	NPT	4
4 Branches/4 Valves	FSM4-13-N-C	3/4"	NPT	4
8 Branches/8 Valves	FSM8-12-N-C	1/2"	NPT	8
8 Branches/8 Valves	FSM8-13-N-C	3/4"	NPT	8
12 Branches/12 Valves	FSM12-12-N-C	1/2"	NPT	12
12 Branches/12 Valves	FSM12-13-N-C	3/4"	NPT	12
Steam Distribution (D) Manifolds				
4 Branches/4 Valves	FSM4-12-N-D	1/2"	NPT	4
4 Branches/4 Valves	FSM4-13-N-D	3/4"	NPT	4
8 Branches/8 Valves	FSM8-12-N-D	1/2"	NPT	8
8 Branches/8 Valves	FSM8-13-N-D	3/4"	NPT	8
12 Branches/12 Valves	FSM12-12-N-D	1/2"	NPT	12
12 Branches/12 Valves	FSM12-13-N-D	3/4"	NPT	12

Connection Codes: **N** = NPT, **SW** = Socket Weld

For Socket Weld Connections: change **N** in Model code to **SW**.

Example: **FSM4-12-SW-C**

CAPACITIES

Pressure (PSIG)	Condensate (lbs/hr) ¹	Steam (lbs/hr) ²
25	1850	160
50	1000	310
75	840	460
100	610	730
125	660	760
150	620	900
200	570	1200
250	535	1500
300	510	1800
400	470	2350
500	460	3000
600	440	3550

¹Saturated condensate discharging into 20 PSI back pressure

²Saturated Steam flow @ 5000 ft/min velocity

MATERIALS – FSM

Body	Forged Steel, A105
Hand Wheel	Sheet Metal
Bonnet	Forged Steel, A105
Valve ring above	Graphite
Valve ring below	Graphite/Stainless Steel
Piston	Stainless Steel, A304